

# THE Dental Trader

**FREE ADS FOR DENTISTS & STAFF!**

VOL. 12 NO. 12 • December '15  
So. Calif. Edition

Ph: 877-888-4237 • 949-429-6836  
Fax: 949-498-1198 • DentalTrader.com

*Buy, Sell or Trade all things Dental*



**EZ 2000 DIGITAL DENTAL SYSTEM**

## Digital Dental X-Ray System Half-Price Special

### DIGITAL SYSTEM INCLUDES:

Everything you need for a Digital Exam Room!

Hi-Quality Diagnostic Digital X-Ray Sensor & Intra-Oral Camera, Dell i5 Computer & 22" Monitor with 3 Year Onsite Warranty, External Backup Drive, Surge Protector, Mobile Cart (Pole or Rectangular), EZ 2000 Plus Advanced Practice Management Software & Integrated Imaging Software (or keep your own billing software & we provide bridge for free), Full Blown Color Coded Scheduler, Graphic 3D Movable Tooth Charting, Timeclock, Installation, Onsite Training & Technical Support.

**\$9,995**

Regular Price: \$19,990

**BBB  
A+ Rated**



Call for your **FREE**  
in-office Demo:  
**800-273-5033**

### Or Lease to Buy:

- No Money Down
- No Payments for 90 Days
- \$220 per mo. for 60 mos.
- \$1.00 Buyout

**\*Free Apple Watch\***  
with purchase



*Perfect for the dentist - glance at your notifications without touching anything, and keep your phone in your pocket so that you can keep working on your patient.*

**Video Demo @**  
[www.ez2000digital.com](http://www.ez2000digital.com)

"Schedule your  
**FREE In-Office  
DEMO Today!**"

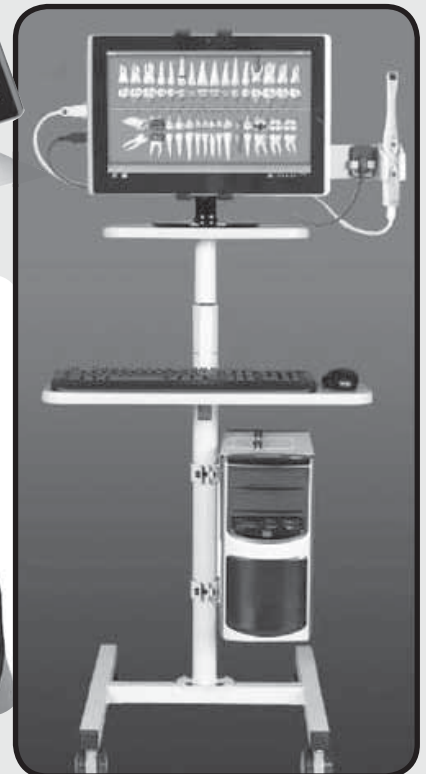

**The Most Advanced Digital Dental Office Solution on the Market Today**

- Sharpest Image Quality Digital Sensor
- Graphic Tooth Charting with 3D Movable Teeth
- Text Messaging and Emailing, Medical Cross-Coding
- Patient Kiosk Entry, Mobile App, Signature Pad
- Optional Integrated Benefit Service by Trojan Prof. Services, as well as Credit Card Processing & Electronic claims

**We bridge to virtually all practice management systems**

# HOW DOES YOUR PRACTICE TRANSACTION ATTORNEY STACK UP?...



**PATRICK J. WOOD,  
JASON P. WOOD &  
MARC ETTINGER**

**ATTORNEYS AT LAW**

- Legal Advisors to over 15 Dental Societies
- The Chosen experts on Business Transactions for Dentaltown
- 180+ Dental Practice Transitions in 2014
- Providing service to clients NATIONWIDE

*"As frustrating as this whole situation was, I don't feel like I missed out on anything. Everything about this deal was sketchy from beginning to end. However, I wanted to thank you for all of your help because you constantly helped me from making irrational decisions out of fear and impatience."*

**NANCY NGUYEN, DDS**  
New York, New York



800-499-1474



[www.DentalAttorneys.com](http://www.DentalAttorneys.com)

**Specializing in**

Practice Acquisitions/Sales, Partnerships, Business Transactions,  
Lease Negotiations, Estate Planning, Transitions & Business Litigation

Wells Fargo Practice Finance

WELLS  
FARGO

## We're here to help you every step of the way



Thinking about purchasing or starting a practice? Let's talk.

**Call us for a complimentary consultation.**

**Sina Mansouri**

Orange County, San Diego • 1-855-544-0245

**Kris Nishihira**

LA Coastal, Southern LA Metro • 1-855-405-2107

**Jason Schneller**

North LA, Central Coast • 1-888-220-7321

Or visit us at [wellsfargo.com/dentaltrader](http://wellsfargo.com/dentaltrader).

### ADA Business Resources<sup>SM</sup>

*Wells Fargo Practice Finance is the only practice lender selected especially for ADA<sup>®</sup> members and endorsed by ADA Business Resources<sup>SM</sup>.*

All financing is subject to credit approval.

ADA<sup>®</sup> is a registered trademark of the American Dental Association. ADA Business Resources<sup>SM</sup> is a service mark of the American Dental Association.

ADA Business Resources is a program brought to you by ADA Business Enterprises, Inc., a wholly owned subsidiary of the American Dental Association.

© 2015 Wells Fargo Bank, N.A. All rights reserved. Wells Fargo Practice Finance is a division of Wells Fargo Bank, N.A. ECG-1706301

Together we'll go far



**CEREC** 3 Redcam with Milling Unit With lots of supplies. \$9,000 OBO [syk9020@gmail.com](mailto:syk9020@gmail.com).

**For Sale** SOREDEX Digora Optime Dental X-Ray Machine. 760-434-5066 San Diego.

**Looking for** used/Secondhand Gendex 765DC Sensor #1. 818-716-0297.

**Dental Xray** duplicator machine \$88 OBO 3109805265.

**ESPE** Pentamix 2 in very good condition for \$125 Call 989-390-1998.

**Advanced Zoom** Whitening lamp for sale. Works like new. \$550 OBO 310-994-5336.

**WHY A DENTAL CPA?** Call 714-259-0505 Wiederman & Chamberlain, CPA.

**Dental** Buffalo No. 1A Vibrator. Never used. \$70. OBO 949-202-4420.

**ENDODONTIST** needed 1 day a month in our Carson office. Please email to [caredental4you@gmail.com](mailto:caredental4you@gmail.com).

**Irvine spectrum** dental space avilabel For share or lease. Contact fax: 9495527900.

**Receptionist** needed in Wilmington Email Resumes to [fshadaieedental@yahoo.com](mailto:fshadaieedental@yahoo.com).

**Dentist retired** Sell all equipment. Call for detail 562-260-5050.

**Dentist P/T** needed in Burbank. Please email CVT to [dentistsassociates@gmail.com](mailto:dentistsassociates@gmail.com).

**dental lab** pressure pot \$88 OBO 3109805265.

**PLACE A FREE AD TODAY!** See FAQs page at [dentaltrader.com](http://dentaltrader.com).

**Key locations** available for total buildout - call Greg Beamer 909-542-4891.

**Once in lifetime opportunity!** Take over Million\$ on 3days practice for nominal deposit. Palm Springs area. Ready To Go! [rdrapilot1@gmail.com](mailto:rdrapilot1@gmail.com).

**ASSOCIATE DENTIST** NEEDED IN PRIVATE DT LA OFFICE. EMAIL RESUME: [GANJIDENTAL@YAHOO.COM](mailto:GANJIDENTAL@YAHOO.COM).

**Space for lease** for Dental Lab inside the Dental Office. For more info call (310)308-3097.

**Private Practice** located in West Hills. Dental Assistant Part-time position available. Please Email for more details attach resume. Email: [dentistrygm@gmail.com](mailto:dentistrygm@gmail.com).

**Dental spaces** for lease at 9241 Reseda Blvd in Northridge. Recently remodeled medical building. 818 709-8645.

**Board Certified** Periodontist Available Will Bring all instruments Contact:[periodontalexpert@yahoo.com](mailto:periodontalexpert@yahoo.com).

*Happy Holidays!*



PRACTICE SALES AND LEASING



Paul Maimone Broker/Owner  
CA Broker #01172430

CA REPRESENTATIVE FOR THE NATIONAL  
ASSOCIATION OF PRACTICE BROKERS (NAPB)

### KERN COUNTY

**BAKERSFIELD #29 - PRICE REDUCTION!** (4) op comput. G.P. (3) ops eqt'd, (4th) plumbed. Located in a free stand bldg. Cash/Ins/PPO/HMO pts. Digital x-rays. Annual Gross Collect \$300K+ on a part time schedule. Seller is moving and is motivated.

**BAKERSFIELD #31** - (4) op computerized G.P. & free standing Duplex Building for sale with excellent signage & visibility. (3) ops eqt'd / (4th) plumbed. Cash/Ins/PPO pt base. No HMO & no Denti-Cal. (46) years of Goodwill. Annual Gross Collections approx \$350K. Office does no advertising. Refers out all Ortho, Perio Surgery, Implant Placement, complicated Endo, & complicated O.S. **NEW**

**So. KERN COUNTY - PRICE REDUCTION!** (6) op comput. G.P. located in a Bakersfield suburb in a small strip ctr. with exposure/visibility. Pano eqt'd. Limited competition. Cash/Ins/PPO/HMO Denti-Cal pts. Annual Gross Collect. approx \$350K part time. Seller is moving and is motivated.

### LOS ANGELES COUNTY

**ARCADIA** - (4) op computerized G.P. located in a well known Prof. Bldg. on a main thoroughfare. Cash/Ins/PPO pts. Annual Gross Collect \$300K+ on a (3) day week.

**MONTEBELLO** - (4) op comput. G.P. (2) ops eqt'd/(1) add. plmbd & (1) add. unplmbd. Located in a large busy shopping center w excell. exposure/visibility/signage & parking. Annual Gross Collect \$200K on a (2.5) day/wk p.t. schedule. Cash/Ins/PPO pt base w no HMO's or Denti-Cal. Office receives many walk-in patients. Very low overhead. Seller does no advertising. Seller is retiring but will assist w a Transition. **NEW**

**MONTEREY PARK - PRICE REDUCTION!** (6) op fully equipped computerized G.P. Located in a store front on a main thoroughfare with exposure, visibility & signage. Digital x-rays. Annual Gross Collections \$250K+ on a part time schedule. Cash/Ins/PPO pts. Seller is retiring but will assist with the transition.

**SAN FERNANDO VALLEY** - (8) Op fully equipped computerized G.P. with central nitrous. Located in a multi story high rise professional building on a main thoroughfare. Cash/Ins/PPO/HMO Patient Base with approx. \$7K/mos Cap Cks. Dentrax (G5), Digital X-Rays & CT Scan. 2014 Gross Collections of \$1.33M+. 2015 Projected Gross Collections of \$1.4M. Open (5) days/week with no nights & no weekends. Averaging 50+ new patients/mos. (5) Hygiene days/wk & (7) DDS days/wk. Refers out Ortho, some Endo & some Perio surgery. 40+ Years of Goodwill. See full page ad for this opportunity on page 71 of this issue. **NEW**

**SHERMAN OAKS #4 - PRICE REDUCTION!** (3) op comput G.P. located in a well known medical/professional building on a main thoroughfare. Cash/Ins/PPO patient base. Annual Gross Collect of approx. \$160K on a (3) day week. Great starter, satellite or buy and combine.

### ORANGE COUNTY

**SANTA ANA** - Absentee owned (6) op fully equipped G.P. located in a smaller two story building on a main thoroughfare. First floor street frontage with exposure/visibility/signage & parking. Cash/Ins/PPO patient base with no HMO and no Denti-Cal. Computerized and Pano equipped. 2014 Gross Collections of \$549K+ on a (3 1/2) to (4) day Associate run week.

### D&M SERVICES:

- Practice Sales & Appraisals
- Expert Witness Court Testimony
- Practice Search & Matching Services
- Medical/Dental Bldg. Sales & Leasing
- Practice & Equipment Financing
- Pre-Death and Disability Planning
- Locate & Negotiate Dental Lease Space
- Pre-Sale Planning

**TUSTIN** - (4) op TURNKEY OFFICE with some included charts. (Charts included, but not guaranteed). (3) ops eqt'd/4th plumbed. Office located in a busy shopping center, on a main thoroughfare, with exposure/visibility/signage and ample free parking. Newer high end buildout with new tile flooring, Italian leather dental chairs, digital x-rays, networked, fully instrumented, etc. Computers and Dental s/w also included in the sale. **PENDING**

### RIVERSIDE COUNTY

Room for Your Riverside County Practice Listing.

### SANTA BARBARA COUNTY

**CENTRAL COAST/WINE COUNTRY** - (3) op comput G.P. & 1,900 sq ft free standing bldg. for sale. Bldg. houses the dental office and a residential unit. Live in unit or rent it out! "Fee for Service" Practice. No HMO, PPO, or Denti-Cal. 2015 Projected Gross Collect \$280K part time. Growth potential. Seller refers all specialties and does little advertising. Seller retiring but will assist with Transition. **NEW**

### SAN BERNARDINO COUNTY

**RANCHO CUCAMONGA** - (4) op comput. G.P. located in a large shopping ctr with excellent exposure/visibility/signage & ample free parking. Modern equipment and digital x-rays. Gross Collect \$586K in last (12) mos. Cash/Ins/PPO/Denti-Cal pts. Low overhead office. Excellent growth potential. Seller refers diff. Endo and most surgeries and does no advertising other than website. **PENDING**

### SAN DIEGO COUNTY

Room for Your San Diego County Practice Listing.

### SAN LUIS OBISPO COUNTY

**GROVER BEACH** - TURNKEY OFFICE. (2) ops of newer eqt. Digital x-ray and Pano. Computerized and networked. Dentrax s/w & Shick sensors. Located in a strip center on a main thoroughfare. Exposure/visibility and signage. Very low rent. Priced less than build out costs. Will go quickly. **NEW**

### VENTURA COUNTY

**CAMARILLO** - (3) op comput. G.P. (2) ops eqt'd/(3rd) plumb. Located in a large strip ctr. with signage & ample free parking. Older eqt. 2015 Gross Collect projected @ \$125K+ part time. Cash/Ins/PPO pts. Low overhead office. Excellent growth potential. Seller does no advertising. Priced below build out cost. Seller retiring. **NEW**

**OXNARD** - (4) op comput. G.P. Located in a prof. bldg. with ample free parking. Dentrax s/w & digital x-rays. 2014 Gross Collect \$264K+ on a (3) day week. Cash/Ins/PPO/HMO/Denti-Cal pts. Seller refers diff. Endo & O.S., all Perio & Ortho. and does no advertising. Seller taking non profit position. **NEW**

**THOUSAND OAKS** - (4) op comput G.P. (2) ops eqt'd/(2) add. plumbed. Located in a beautifully built out condo located in a landmark prof. bldg. on a main thoroughfare. Turnkey Office w included charts. Charts included but not guaranteed. Newer Sirona eqt, Midmark cabinets, Dentrax s/w & digital x-rays. Annual Gross Collect approx. \$120K - \$130K/yr p.t. Seller moving. **NEW**

### UPCOMING PRACTICES FOR SALE

Central Coast, Culver City, Downey, Fountain Valley, Glendale, Glendora, Hacienda Heights, Laguna Hills, Los Angeles, Mission Hills, Montebello, Palmdale, San Fernando Valley, San Gabriel, Santa Barbara, Santa Clarita Valley, Temecula, Thousand Oaks, Torrance, Union City, Ventura Cty., Visalia & West Covina.



"The Personalized Service  
Dental Broker"™

P.O. Box #6681, Woodland Hills, CA. 91365  
(866) 425-1877 Outside So. CA or (818) 591-1401

www.dmppractice.com

# LCF Financial Services

A Division of LCF Financial, Inc.

*With over 20 years of experience,  
LCF is able to offer financing for all of your practice needs.*

## 100% Practice Financing!

## 100% Real Estate Financing!

Call Today for a Free Consultation!

Toll-Free: 1.800.550.9228  
Email: Practice@leffin.com

Direct Line: 1.714.550.7494  
Website: LCFPracticeSales.com

**Wooden shelf unit** Perfect for charts. Great condition. 67"x51"x12". Photos on request. Make reasonable offer. Paul. paulkratzer@yahoo.com. 323-528-1442.

**WESTLAKE VILLAGE DENTAL CONDO FOR SALE** Ground floor condo with 1,012 sq ft. Currently built out with two dental chairs. Upgraded features with modern décor. Ample free medical parking. Premier location for professionals. Linda Brown (818)466-0221 TOLD Partners. CalBRE #01465757.

**CERRITOS, CA** PT position available 2 days/WEEK. Proficient in MOLAR RCT and extractions. PLEASE FORWARD YOUR RESUME TO jes.innovative@gmail.com.

**Experienced** board-certified periodontist in your office. LANAP laser gum surgery, extractions, grafting, implants. Brings own materials. Email socialimplants@gmail.com.

**Looking for a dental office** preferably seller retiring/ in transition, Immediate available to work as an associate. contact 7142997653.

**Santa Ana** We are seeking a Dental Practice Manager/ Treatment Coordinator/Dental Assistants. www.AcevedoDentalGroup.com Contact Ivan (323)724-1010.

**GP WITH ALL ASPECT** OF DENTISTRY NEEDED IN OUR OFFICE 2 DAYS A WEEK. PLEASE FORWARD YOUR RESUME TO CAREDENTAL4YOU@GMAIL.COM.

**Encino** A private practice for sell, 4 Ops, all digital, CT scan, Laser, CEREC. 8182358650.

**Dentist Needed** for a PPO office in Upland. E-mail resume to: caringdds81@gmail.com.

**SANTA CLARITA** RETAIL DENTAL OFFICE FOR LEASE: Beautiful built out Class "A" retail office on a high traffic corner with great visibility. 1,515 sqft, with four plumbed operatories, custom cabinets, as well as other amenities. Dental chairs, vacuum/compressor available for purchase. Linda Brown (818)466-0221. TOLD Partners, CalBRE #01465757.

**USED** dental operatory chair, light, delivery system, and cuspidor for sale \$799. needs a minor repair. kjangdds@gmail.com.

**Super Pediatric Dentists** Needed in San Diego, CA. Please email resumes to careers@thesuperdentists.com.

**iTecGuide** (make by CAD/CAM system for implants) 10 micron accuracy \$199. Place implants in less than one minutes info@moderntechinc.net.

**HANDPIECE** (MIDWEST #07-042-8854) Like New, Original Cost \$799, Make Offer. 855-772-7645 or janetm@hygiacare.com.

**Dental Equipment for sale** Used dental equipment for sale in California. Email makennabarnes@hotmail.com for available equipment and price sheet.

# INCORPORATE THE *RIGHT WAY!*

- Choose the right name, tax status, and filing date
- Justify a “reasonable” S corporation salary
- File all required federal/state regulatory, tax and securities forms
- Preserve the corporate identity with strong minute book maintenance

*Final Result:*  
**Less Taxes, Limited Liability,  
and IRS Audit Protection.**

**#1 Avvo® Rated Corporations  
Attorney in USA**

**USC Law 1984**

**Dartmouth College 1981**



**Robert W. Olson, Jr., APC**

**Full Service Flat Rate Incorporations  
Customized Annual Corporate Minutes  
Corporate Compliance Review  
Minute Book Rehabilitation**

**888.963.1120**

**RWO@transdental.com**

**www.transdental.com**

# “YES DOCTOR, YOUR LOAN IS APPROVED.”

*Not hearing that from your current lender? We can help.*

We look at the total financial package. We have more latitude with terms and rates than the “big banks”. We are not burdened with corporate red tape and are able to fund our loans locally and quickly.

**Why Wait? Call Howard Boles today.**  
**949.379.5704**  
**hboles@ocbusinessbank.com**



**Orange County  
BUSINESS BANK**

1/15



## **Orange County Business Bank Professional Practice Finance**

- Practice Acquisitions
- Partnership Buy-ins/Buy-outs
- Refinance & Debt Consolidation
- Office Expansion/Relocation
- Working Capital
- Equipment Purchases

949-221-0001

[www.ocbusinessbank.com](http://www.ocbusinessbank.com)

17901 Von Karman Avenue, Suite 100, Irvine, CA 92614

**GP looking to buy PPO/FFS practice** from retiring dentist or dentist looking to partner. [dr.lcassaad@gmail.com](mailto:dr.lcassaad@gmail.com).

**Orthodontic Assistant Needed** Part time. DA or RDA preferred w/ x-ray licence. Email: [fullsmileoffice@gmail.com](mailto:fullsmileoffice@gmail.com).

**Intraoral Cameras ANNUAL SALE!** Get distributor pricing using PROMO code TRADER on [www.Lensiora.com](http://www.Lensiora.com). Offer limited to inventory on hand!

**CENTURY CITY TURN-KEY DENTAL OFFICE FOR SALE** Five operatories approximately 1,093sqft, fully equipped with rear delivery system. Beautifully designed office with fabulous view of the City. Great startup opportunity or a second office. Building rarely has vacancies, landlord will work with tenant for a new lease. Linda Brown (818)466-0221, TOLD Partners, CalBRE #01465757.

**Is it the right time** to list your practice? Find out from Dr. Russell Okihara, Henry Schein PPT 619-694-7077.

**Don't sign your office lease** without knowing what's in it! Talk to a skilled dental attorney regarding the ins and outs of your lease. Levi Barlavi. (310) 776-5384 [www.dental-attorney.com](http://www.dental-attorney.com).

**Looking to finance** a practice? Contact Live Oak Bank. Our specialized lenders will build a customized loan to meet your financing needs. 877.890.5867 [www.liveoakbank.com/healthcare](http://www.liveoakbank.com/healthcare).

**For Lease** Beverly Hills Operatories \$100/day. In state of the art office. Ask for Dr. Paul 310-666-3925.

**All County Construction** We're Building your Future. YOUR satisfaction is OUR main priority. Call Today 714-240-7179.

**Finished 1800SF** general dental office in Poway for lease. 5 plumbed operatories. No chairs/equipment. Email [jimim74@yahoo.com](mailto:jimim74@yahoo.com).

**CEREC** 4.3 Bluecam/milling unit 2012 and Ivoclar Vivadent oven for SALE. Under Warranty. Total \$70000.00. CALL 916-920-1170.

**Dental assistant needed** in South Gate for high volume children's dentistry. Full time + benefits. Send resume to: [dtresume@cdgdental.com](mailto:dtresume@cdgdental.com).

**Pediatric dental office** seeking P/T orthodontist in San Diego. Must be friendly, energetic and committed. Email CV to [hologicdoc@gmail.com](mailto:hologicdoc@gmail.com).

**“Increase the value** of your dental practice by filing for federal trademark protection. Call today for your free consultation.” Law Offices of Amy L. Borden, Esq. (888)416-1321. [www.californiadentalattorney.com](http://www.californiadentalattorney.com).

**DANA POINT** Exceptional Opportunity in a 3 OP Fee for Service Practice. 2014 Gross \$583,277 with adjusted net of \$221,000. 33 years goodwill. [hlocker@yahoo.com](mailto:hlocker@yahoo.com).



# San Diego Practice Sales

*SAN DIEGO'S MOST EXPERIENCED,  
TRUSTED & ACTIVE BROKER (since 1990)*

**We have sold HUNDREDS of Practices totaling several MILLIONS of Dollars!!**

**VISTA – JUST LISTED!!** GENERAL Practice situated in Retail Center along VERY busy thoroughfare. 4 Ops (3 equipped) in approx. 1400 sq. ft. ALL Digital and Paperless! Dentrix Software. Panorex. All Insurance and Cash Patients.

**LA MESA – JUST LISTED!!** GENERAL Practice and **BUILDING** located on Busy thoroughfare. 5 equipped Ops (plus 1 plumbed) in approx. 2700 sq. ft. Digital X-Rays and 1 year old Digital Pan.

**NATIONAL CITY – JUST LISTED!!** GENERAL Practice with 3 Ops with 4 year old equipment. Approx 1163 sq. ft. Situated along busy street in business/residential area.

**RANCHO MIRAGE –** Doctor retiring from estab. **GENERAL** Practice situated in Busy, Upscale retail center. 4 Ops in 1500 sq. ft. Pan-Ceph. Owner refers out LOTS of dental care!

**OCEANSIDE –** Equipment and Leasehold Improvements. 3 ADEC Ops (1 more plumbed) in 1375 sq. ft. Introral Cameras, Panoramic, Digital X-Ray, Rotary Endo, and more. Owner leaving country. VERY low price for quick sale!!

**MIRA MESA –** 20+ year **GENERAL** Practice has 4 Ops in approx. 1300 sq.ft. Situated on corner of busy intersection. Primarily PPO.

**LEMON GROVE –** **GENERAL** Practice in high traffic strip mall. 4 Ops in 1100 sq. ft., has digital. Cash, PPO, Cap. Absentee owner.

**Also Serving The INLAND EMPIRE!!**

Practices available in **COLTON, SAN BERNARDINO, MURRIETA**

for updates, please visit us at  
**WWW.SDPRACTICESALES.COM**

SAN DIEGO PRACTICE SALES can also assist you with PRACTICE APPRAISALS, BUY-IN BUY-OUT TRANSACTIONS and LEASE NEGOTIATIONS.

For More Information Call:

**Mike Hostler (760) 599-7828 Bob Fleming, D.D.S.**  
(voice mail)

SERVICE --- INTEGRITY



# DENTAL LAW LITIGATION ATTORNEYS

*Over 19 years of in court experience, with hundreds of dentists  
and over 35 hospitals represented*

**Loan Issues • Buy/Sell  
Real Estate • Partnership  
Buy/Sell Agreements  
Lease/Real Estate • MSOs  
Contract/Business  
Partnership/Employment  
Lawsuits/Defense**



Shab David Kerendian, Attorney

*"Kerendian & Associates has represented me in over 25 matters in court or arbitration against insurance companies. They are responsive and caring. I am very satisfied."*

-James H.I. Bicher, M.D., Oncologist, Valley Cancer Institute, Los Angeles, Ca.

*"I saw Mr. Kerendian argue the case in court, and was greatly impressed. I highly recommend him."*

-Peiman Soleymani, D.D.S., Periodontist Los Angeles, Ca.

*"Having been represented by Mr. Kerendian many times, I was impressed with his expertise, quick response to questions, and degree of care."*

-Mark Davidson, M.D., Los Angeles, Ca.

*"I have been working with Mr. Kerendian, and he has shown utmost professionalism and devotion to me."*

-Dan P. Benyamini, D.D.S., Family Practice, Los Angeles, Ca.

## KERENDIAN & ASSOCIATES ATTORNEYS AT LAW

*Free Consult Over the Phone • Flat Fee Packages Available*

11755 Wilshire Blvd., 15th Floor, Los Angeles, Ca. 90025

**Ph: 888.299.7848 • shab@kalawcorp.com • 310.914.4143 • Fax: 310.914.5441**

91215

**Our 9th Annual** Dental Skills Series in OC includes 6 Courses: Endo, Pedo, Hands-on Oral Surgery, Mandatory Infection Control, Restorative Dentistry and More...only \$599 and 42 CEs! Visit [www.xcelseminars.com](http://www.xcelseminars.com) for info.

**IMMEDIATE** position available for experienced RDA. Bakersfield. Private practice: 1 dentist. Digital office. Office performing general, implants, and Invisalign. [trojandude26@gmail.com](mailto:trojandude26@gmail.com).

**We are THE LEADING ADVISORS** to more than 15 DENTAL SOCIETIES. See our website for upcoming events/seminars in your area. 800-499-1474 WOOD & DELGADO [www.dentalattorneys.com](http://www.dentalattorneys.com).

**DDS XPRESS REALTY** Your connection for all your Real Estate Needs (Commercial Properties, Investment Properties) Tina Ochoa, Realtor BRE # 1049085 (951 309-3196).

**4 op woodland hills** office for sale. dentist to retire. Nice high tech office 805-443-0642.

**Thank you** for helping my family select medical coverage! With your help we have the right one! – Todd Brilliant DDS, San Diego. [www.TheDoctorsInsuranceBroker.com](http://www.TheDoctorsInsuranceBroker.com).

**Associate Dentist needed** Fridays for state-of-the-art office in Laguna Hills. Send resume to [aliciadental@gmail.com](mailto:aliciadental@gmail.com) or fax to 949-770-8336.



In an industry that is changing constantly, wouldn't it be nice to find a banker that understands the needs of your practice? A bank with a team of professionals who can deliver solutions to help meet both your short-term and long-term goals. At Sunwest Bank, having an in-depth understanding of the needs and goals of your practice is fundamental to the way we work with you.

### Loan Products and Services:

Commercial Real Estate Loans and Refinances  
Practice Acquisitions  
Refinancing Your Practice Loans  
Equipment Financing  
Partner Buy-in and Buy-outs  
Practice Expansions (Multiple Locations)

### Deposit Accounts and Services:

Online Banking  
Remote Deposit  
Visa/ATM Cards  
Wire Transfers  
Merchant Card Processing  
ACH  
Zero Balance Accounts

### For more information contact:

#### Jim Martin

Senior Vice President  
Practice Finance Specialist  
714.730.4496 direct | [jmartin@sunwestbank.com](mailto:jmartin@sunwestbank.com)



SUNWESTBANK.COM

**Complete Sensor** and Practice Management with EHR. Package includes everything you need to take x-rays and collect your money from insurance and track your patient's care. Call 1(800)397-6046.

**General dental office** in search of an Endodontist for 1-2 days/month. Send resume to [angieurb34@gmail.com](mailto:angieurb34@gmail.com).

**Brand new** child/pediatric lead apron with thyroid collar. Navy blue Dentsply-Rinn Soothe-guard, silky, newest model. 310-922-5666, Santa Monica \$110.

**WESTLAKE VILLAGE DENTAL OFFICE FOR LEASE:** Beautiful dental build out with large lab, staff room, private office, business office, with six operatories. Class "A" corner spacious office, along window line, 2,992sqft. Centrally located with ample free parking. Linda Brown (818)466-0221 TOLD Partners, CalBRE #01465757.

**WEST COVINA PRACTICE AND BUILDING FOR SALE** High quality, retiring Dr. does all facets of dentistry including some ortho and implant. 35 years goodwill - Grosses over \$800,00 on 3 1/2 days/week - 5 operatories in 1700 sq ft - very modern, includes Cerec - Building 3300 sq ft on 13,000sq ft lot with own parking lot - Thomas & Fees Practice Sales (714) 544-4341.

**RDA COURSES** Coronal Polishing, Radiation Safety, Infection Control, BLS/CPR. CEUs \$19 Online: 2 Hr Infection Control, Dental Practice Act.(888) 988-2364 [www.ADMInstitute.com](http://www.ADMInstitute.com) [info@adminstitute.com](mailto:info@adminstitute.com).

**Is now the right time** to list your practice? Find out from Mario Molina, Henry Schein PPT 323-974-4592.

**Dental Chair/Operatory** for rent. South Orange County. Digital Office, flexible hours. E-mail: [Silvana\\_001@yahoo.com](mailto:Silvana_001@yahoo.com) Call (949)448-0274, or (949)374-3340.

**COLTON** Just listed! Equipment and leasehold improvements. 3 ops equipped. with 4th possible, Panoramic. Good location and visibility. [iepracticesales.com](http://iepracticesales.com) (951) 816-6242.

**receptionist/assistant** needed for Pedo office in Canoga Park. Email to [samslosangeles@gmail.com](mailto:samslosangeles@gmail.com).

**\$1000 Rebate** on Dry Vacuum System, \$3995 update your old vacuum system to New Drought Tolerant Standards. Made in USA. Call (800) 423 - 5657 or visit [DHPDENTAL.COM](http://DHPDENTAL.COM) for more details.

**DENTAL HANDPIECE REPAIR** 50% OFF New Customers Only. Premium Parts Standard. Contact Us Today! 877-535-1733 / [www.repairmakers.com](http://www.repairmakers.com).

**Temple City** Dental Practice Leasehold for lease, \$2500/mon, Rosemead Blvd, 4 equipped OPs, 2X-rays, 2 sensors, 1200+ charts included. contact [lilyppoon@yahoo.com](mailto:lilyppoon@yahoo.com).

**Key locations** available for total buildout - call Greg Beamer 909-542-4891.

**Got the Denti-Cal blues?** Let's face it, Denti-Cal is a complicated and challenging dimension of dentistry...don't go it alone. Let Kerendian & Associates guide you. 888-299-7848.



## PRACTICE SALES & APPRAISALS

We are pleased to present . . .  
**These outstanding practice opportunities**

**ANAHEIM:** Over 19 years of Goodwill. Turnkey Opportunity. Busy Shopping Center.

**DIAMOND BAR:** Shopping Center. Super Look 4 Ops. Retiree. Big upside.

**DOWNEY:** Pre-Approved for 100% Lender Financing. Shopping Center with Visible Sign.

**ENCINITAS:** Shopping Center. Beautiful Facility. Revenues \$35k/mo. Absentee Owner.

**GLENDORA:** Retiree with Private Practice. Low Overhead. Excellent opportunity.

**HISPERIA:** Retiree. Shopping Center. Very Neat. Low Overhead. Huge Upside!

**IRVINE:** Long Established Private Practice. Active Hygiene Schedule. Seller Retiring.

**LOS ANGELES (West):** Private Practice. Seller Retiring. Low Overhead.

**LOS ANGELES (Downtown):** Major Sign Visibility. Seller Retiring. Growth opportunity.

**LOS ANGELES:** Shopping Center. 4 ops. Gross of \$35k/mo on Part-time Schedule.

**MONTEREY PARK:** 1st floor. Visible. Clinic. Absentee Owner Opportunity.

**NORTHRIDGE:** Retiree with 20+ years goodwill. Free Standing Bldg. Huge Upside!

**PALMDALE:** Retiree. 20+ years of Goodwill. HMO income of \$5K/mo. Priced Right.

**REDLANDS:** Private Practice. Over 40 years of Goodwill. Ideal Starter Practice.

**SANTA BARBARA:** Busy Practice. Seller Retiring. Sale Price under \$400K.

**SF VALLEY:** Profitable w/20 years of Goodwill in North Valley. Hispanic Patients.

**SANTA CLARITA:** Hi-End Private Only Practice. Modern Facility & Equipment. Must See.

**TORRANCE:** Busy Shopping Center. Proximity to Freeway. Low Selling Price.

**VALLEY VILLAGE:** Long-established Practice with significant Upside Potential.

**VAN NUYS:** Must See Shopping Center Opportunity.

**VICTORVILLE:** Retiree. Quality Oriented. Transition.

### Listing in Other Areas We are Processing

Hemet, La Jolla, Lancaster, Modesto, Montclair, Ontario, Oceanside, Temecula, San Jose

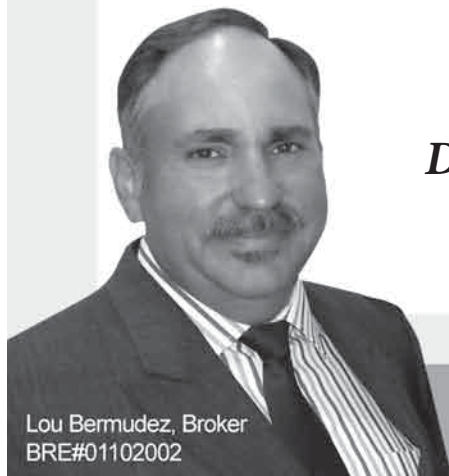

Lou Bermudez, Broker  
 BRE#01102002

*Dental Practice Brokerage and Appraising  
 for Over 30 Years*

**PHONE: 818.999.9595**  
[www.ddspracticesales.net](http://www.ddspracticesales.net)

# Want a Dramatic Practice Face Lift?

No job too big or  
too small....we do it all.  
Best rate you'll get!

Now is the perfect time  
to do Tenant Improvements!  
Transform your practice into  
a functional work of art.  
We've designed some of  
the most beautiful dental  
offices in California.



**DESIGN/BUILD**  
Plan and Permit Services  
T.I.'s - Remodels - Expansions  
Free Standing Buildings  
Turn-Key Packages  
Consultation  
*Free Estimates*

**ALL  
COUNTY  
CONSTRUCTION**  
Bradley Jordan Construction Co., Inc. dba All County Construction

Lic. #669244

562-989-3350

E-mail: [jcardio@aol.com](mailto:jcardio@aol.com)

[www.allcountyconstruction.com](http://www.allcountyconstruction.com)

Jim Jordan: 714-240-7179 Cell

# San Diego Practices for Sale

**Periodontic Practice:** Well established with large referral base, nicely appointed office. More details provided upon request.

**North County San Diego:** 4 Ops. GP Practice with Prosthodontics emphasis. 75% Fee For Service. Low Overhead. Nice looking office.

**Vista:** 6 Ops. 1,500 Sq ft. 26 yrs. of Goodwill. Office Condo for sale also. Seller retiring. Located in Professional bldg.

**Endodontic Practice:** North County Inland. Very nice State-of-the-Art practice. Phenomenal growth potential. 3 Ops. Must see to appreciate. Oppty to buy building also. Bargain Price for quick sale.

**Downtown San Diego:** 6 Ops. 3 Equipped. Located by Petco Park. Bay views. Room to expand with extra ops. Large brand new residential planned development close by. Practice has Pano, digital X-ray, and intra-oral cameras.

**Ocean Beach:** Prime high visibility corner located on Ocean beach's busiest street. Very low overhead with no marketing being done. 35 years of goodwill. Fee for service and PPO only. Only four blocks from popular San Diego beach.

**Mission Valley:** High production/High profit office. Great location in busy shopping center. Freeway close.

View our website for current listings at: [www.KRpracticeSales.com](http://www.KRpracticeSales.com)

**SELLERS:** Ask us about our Risk-Free 30-day Listing Agreements!



Ken Rubin Practice Sales, Inc.

4420 Hotel Circle Ct. Suite 350

SAN DIEGO, CA 92108

(619) 299-6161



Ken Rubin

Jonathan Ingalls

11.15

**13 cases** of X-LG powderfree nitrile gloves. Criterion brand. All 13 for \$500.00 + Shipping. email- [hirotadental@gmail.com](mailto:hirotadental@gmail.com).

**PRACTICE FOR SALE TORRANCE** GP in shopping center w/ 3 eq ops; Net \$103K. California Practice Sales, Inc. Phone: 714-639-2775.

**Orthodontist** to take over existing 20 yrs old practice. One day per week. Tarzana [toothopinion@aol.com](mailto:toothopinion@aol.com).

**ULTRADENT ENDO-EZE HAND-PIECE** New-In-Box/Unopened... (serial number: B0304343)..\$885 value/Asking \$550/ obo... text/email questions/offers.....310-941-8506/ [BabyBoomerDentist@Roadrunner.com](mailto:BabyBoomerDentist@Roadrunner.com).

**MULTI-SPECIALTY** Santa Ana - 8 exam rooms. Collections over \$750,000. ID#CA76585. Call Maria at Practice Concepts 877-778-2020 x. 108.

























**WEST HOLLYWOOD DENTAL OFFICE FOR SUBLEASE:** General dentist looking to share space, works only two days a week. Wilshire/Doheny professional building with incredible views of the City. Four operatories, rear delivery system, electric handpieces, digital x-ray, office has numerous amenities. Linda Brown (818) 466-0221. TOLD Partners. CalBRE #01465757.

**BANNING** 6 Ops, recently remodeled, GR of \$1.4M+ in 2014. Room for 4 additional Ops. HSPPT-Steve Caudill 951-314-5542-#CA183.

# KINGS TWO DENTAL SUPPLY

**NOW HIRING**

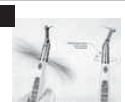
**SERVING DENTISTS FOR OVER 20 YEARS**

<b>OPERATPRY PACKAGE</b>	 <p><b>ENGLE DENTAL SYSTEMS</b></p> <p><b>Bel20/Engle Package Includes:</b> Engle Dental Light Engle Delivery Unit Belmont 20+ Chair <b>Call for Price</b> + Free Doctor Stool</p> 		<b>STERILIZER</b>	 <p><b>Tuttnauer</b></p> <p><i>The Most Reliable Sterilizer in the Market</i> Call us Today for 4th Q. Promo</p>		 <p><b>Statim G4</b></p> <p><i>Fastest Sterilizer in the Market</i> Call us Today for 4th Q. Promo</p> <p><small>\$300 REBATE</small></p>				
	<b>VACUUM</b>	 <p><b>JVBS</b></p> <p><b>JDS VACUUM PUMP</b> WET RING VACUUM PUMP Call us Today for 4th Q. Promo</p>		 <p><b>TECH-WEST VACUUM</b> LIQUED RING VACUUM PUMP Call us Today for 4th Q. Promo</p>		 <p><b>CustomAir VACUUM</b> WATER RING VACUUM PUMP Call us Today for 4th Q. Promo</p>		 <p><b>VacStar VACUUM</b> VACSTAR VACUUM SYSTEM Call us Today for 4th Q. Promo</p>		
<b>COMPRESSOR</b>		 <p><b>JDS COMPRESSOR</b> Available in Oil-less or Lubricated Call us Today for 4th Q. Promo</p>		 <p><b>TECH WEST COMPRESSOR</b> Available in Oil-less or Lubricated Call us Today for 4th Q. Promo</p>		 <p><b>CustomAir COMPRESSOR</b> Ramvac Call us Today for 4th Q. Promo</p>		 <p><b>AirStar COMPRESSOR</b> Top Quality Compressor Call us Today for 4th Q. Promo</p>		
	<b>DIGITAL X-RAY</b>	 <p><b>ScanX Classic</b> Convert your film base Pan/Ceph to Digital Call us Today for 4th Q. Promo</p>		 <p><b>DENT-X EVA Sensor</b> #1 or #2 Sensor W/Docking Station &amp; Software Call us Today for 4th Q. Promo</p>		 <p><b>VATECH EZ Sensor</b> #1, #1.5 or #2 Sensor W/Docking Station &amp; Software Call us Today for 4th Q. Promo</p>		 <p><b>Papaya 3D Digital Pan/Ceph</b> 3D Digital Panoramic X-Ray System W/Software Call us Today for 4th Q. Promo</p>		
<b>AUGUST SPECIALS</b>		 <p><b>I-Root</b> Apex Locator Introductory Offer.....<b>\$599.00</b></p>		 <p><b>Advance Cam</b> USB Intra-Oral Camera System <b>\$595.00</b></p>		 <p><b>Woodpecker UDS-K Piezo Scaler</b> +5 Free Tips.....<b>\$269.95</b></p>		 <p><b>ART M1 Scaler</b> Ultrasonic Scaler System 25K <b>\$329.00</b>+ 1 Free Inserts</p>		 <p><b>ART E-1 Electrosurgery Unit</b> <b>\$419.00</b> + 7 Free Electrodes</p>
	 <p><b>Dentmate LEDEX WL-90+</b> Curing Light + Carries Detector W/Built in Radiometer &amp; 3 Second Fast Cure .....<b>\$449.00</b></p>		 <p><b>Sonix IV ST144</b> Ultrasonic Cleaner W/Timer 3.6qt Tank W/Basket <b>\$399.00</b> +Free Basket &amp; Cover</p>		 <p><b>Endo-A-Class</b> Cordless Endodontic Handpiece <b>\$599.00</b></p>		 <p><b>Dexcown EZ Sensor</b> #1.5 or #2 Sensor W/Docking Station &amp; Software <b>CALL FOR PRICE</b></p>		 <p><b>Digirex PSP Scanner</b> <b>CALL FOR PRICE</b> +12 Phosphor Plates &amp; Free Software</p>	

OFFER VALID UNTIL 12/30/2015

**CALL US TODAY TOLL FREE (800) 715-5464 FAX: 626-581-8137**

Buy it! Sell it! Trade it!!!

# WHY SEND YOUR ENDO OUT?

I Finish ALL Inoperable ENDO with Lifetime Warranty, Apicos, Retreats, Calcified, Unfound, Unusually Curved Canals, Perfs Repairs, Broken Files.

***I PROVIDE EVERYTHING.***

*20 Years Experience - 1000s Done*



***EXCELLENT  
RESULTS!***

*MIN \$36 K NET  
GUARANTEED*

*Ehab Ismail, DDS*

**562-968-4061**  
**www.socalrootcanal.com**

**Endodontist** Please join our group practice. One day per month. Tarzana. Please call Michelle 818 609 0009.

**Professional Services** over \$50 Million loaned to Southern California Dentists. NEED MONEY? We've GOT IT. Call Sunwest Bank 714-730-4412

**Office Closed** Charts Only. Looking for buyer for patient charts-Private & PPO wth minimal HMO. Price negotiable. Huge potential. dentalcareofcalifornia@gmail.com.

**DENTAL PRACTICES WANTED** in Pasadena, Studio City, Monrovia. Fully digital. Existing patient base. Sellers call Loc Pham, Broker at LCF Financial, Inc. BRE#01875780. (714)550-7494 or practice@lcffin.com | LCFPracticeSales.com.

**Mobile Dental Truck** for sale, Van and a Trailer with 2 dental chairs, email mobile dental@mail.com for details.

**PRACTICE FOR SALE** GP in NATIONAL CITY. 3 Ops, 4 year old equipment in approx. 1163 sq.ft. DPS: 760-599-7828.

**DUST COLLECTOR** 60U By Handler Mfg. Never Used. \$550. OBO. 949-202-4420.

**General dentist needed** Friendly with caring personality. Production oriented while maintaining high clinical standards. Minimum 2 yrs experience. Submit resume lvfdental@gmail.com.

**FRESNO** General Dental Practice & Building FOR SALE contact Brooke at 714-259-0501 for more details.



# Thomas & Fees

## Practice Sales

*"A better kind of practice sales company"*

### Practices for Sale

#### Anaheim

**Practice and Building for sale** - Dr. retiring after 37 years in this location – 3 operatories Grosses over \$400,000 on 4 easy days/week with low overhead of 55%– fee for service and private insurance. Building consists of 3 separate building on same lot – 1 is 700 sq ft and 1 is 900 sq ft and both are unoccupied and the 3rd building is two dental offices of 1070 sq ft each.

#### Woodland Hills

**Dr. retiring** after 38 years in very modern, 8 operator, private practice grossing over \$2.2 million/year. No HMO or PPO's. Huge hygiene with 14 days/week of hygiene. Dr. refers out all endo, oral surgery, and perio. Digital x-rays and Dentrux computer system. A true gem.

#### Los Angeles

**Dr retiring** after 44 years in private practice - beautiful, modern 3 operator practice with digital x-rays and ScanX system - very high tech - grosses \$400,000 on 4 easy days/week.

#### Long Beach

**Gorgeous**, modern 5 operator private practice for sale in 2500 sq. ft. - 78 year old owner retiring - 4 1/2 days of hygiene – digital x-rays – Grosses almost \$1.1 million/year with net of approximately \$400,000.

#### West Covina

**High quality practice for sale.** Retiring Dr. does all facets of dentistry including some ortho and implants. Grosses over \$800,000 / year on 3 1/2 days/week – 35 years goodwill. 5 operatories in 3900 sq ft - very modern, includes Cerec – Building 3900 sq ft on 13,000 sq ft lot with own parking lot.

#### Laguna Beach

**Very modern 3 operator office** – digital x-rays with Dexus and Dentrux computer grosses over \$800,000/year with high net income – Dr retiring.

#### Mission Viejo Ortho

**Private orthodontic practice** for sale – 3+ operatories in Professional Bldg – Dr retiring after 20 years in same location – collects over \$13,000/mo on 2 easy days per week – Contracts Receivable of \$67,000 included.

---

## Philip L. Kempler, DMD, Broker

Days (714) 544-4341 • Evenings (949) 362-4749

Cell: (949) 395-6000 • FAX (714) 731-7296

Visit our website at [www.TFPSales.com](http://www.TFPSales.com)

E-mail: [Phldr@cox.net](mailto:Phldr@cox.net)



## Let one of our dedicated healthcare specialists offer your practice a financial check-up

We provide up to 100% financing with competitive rates and terms for:

- Practice Acquisitions
- Practice Loan & Debt Consolidation
- Expansion/Remodel/Relocation
- Commercial Building Purchase/Refinance



### Citi® Healthcare Practice Finance Group

Bob Affleck  
Senior Vice President  
(949) 939-4550  
bob.affleck@citi.com

Commercial Bank



All credit applications are subject to bank approval.

© 2015 Citigroup Inc. Citibank, N.A. Member FDIC. Equal Opportunity Lender. Citi and Citi with Arc Design are registered service marks of Citigroup Inc.

**SUBLEASE NEEDED** in or around Panorama City, Pacoima, San Fernando. Plz email [uclaDDS78@yahoo.com](mailto:uclaDDS78@yahoo.com).

**FOR SALE** Impact Air 45 Surgical Handpiece Not F/O. New turbine and head cap. Just Overhauled 6-month Warranty (323)851-6622.

**Private dental office** is looking for a team member as a TREATMENT COORDINATOR for Hesperia. Please submit your Resume to [f.dentistry@yahoo.com](mailto:f.dentistry@yahoo.com) if you have met the following requirements.

**Dental Laser System** from Premier Laser Systems. Great condition. Photos on request. Make reasonable offer. Paul. [paulkratzer@yahoo.com](mailto:paulkratzer@yahoo.com). 323-528-1442.

**ENDO OFFICE FOR SALE** Encino/Sherman Oaks border, close to 405 and 101 freeway. Established office with 20 years of goodwill. Four operatories, many amenities including Zeiss portable microscope, Kodak digital x-ray, and Softdent software. Linda Brown (818)466-0221. TOLD Partners, CalBRE #01465757.

**Dental Assistant** F/T P/T needed in Rowland Heights Bi-lingual English/Chinese prefer Call 626-965-3338.

**Must be able** to present and close treatments. Competent in insurance, PPO and HMO, billing and collecting. Responsible, trustworthy, positive, and accountable. Strong communication and presentation.

**Want to fulfill** your CE requirements, get 42 CA CEs for one low price, all on Sundays, at one convenient OC location & attend a Hands-on Oral Surgery course, for only \$599? Go to [www.xcelseminars.com](http://www.xcelseminars.com) to see our Southern California course series and register!

**For Sale** Make offer. Dental equipment, instruments and supplies. Three good chairs and two xray units 20 years old. Bakersfield. [drwat3@gmail.com](mailto:drwat3@gmail.com).

**BEVERLY HILLS** General Dentistry boutique office w/valet parking. 2 Ops, 1 equipped. OpenDental, Digital, paperless. 2014 GR \$120K. FFS and PPO only. Mario Molina-HSPPT 323-974-4592-#CA215.

**Dental office for lease** established 12 years, 3 chairs, xray machine Santa Ana call Ranjan 714-931-5785.

**Selling your practice?** Understand potential legal issues with your transition before listing your practice. Free Phone Consultation. Call Levi Barlavi. (888) 776-5384 [www.dental-attorney.com](http://www.dental-attorney.com).

**RDA needed** in Anaheim for high volume children's dentistry. Full time + benefits. send resume to: [dtresume@cdgdental.com](mailto:dtresume@cdgdental.com).

**Create the Office** of your Dreams with All County Construction. Enhanced to your style, designed to your budget. 714-240-7179.

# When it Comes to the Sale

## DENTAL PRACTICES FOR SALE

**PRACTICES FOR SALE IN THE FOLLOWING AREAS:** Burbank, Carson, Duarte, Encino, Lancaster, Los Angeles, Santa Barbara, Simi Valley, Tujunga, Valencia, Victorville, West Covina, Woodland Hills and Yucaipa.

**SANTA BARBARA FEE FOR SERVICE PRACTICE FOR SALE:** Very stable history of collections for the past four years with less than \$5,000 variation from the lowest to the highest year with average annual collections of \$772,000 and average net income of \$225,000 per year. Seller works a short four day work week with four and one-half days of hygiene per week. Seller refers oral surgery, pedo, difficult endo and ortho. Great office location in downtown Santa Barbara within walking distance of the government center and many major employers in the community. Top floor location with private elevator access, ceiling skylights, and newer leasehold improvements. Four equipped operatories with digital x-rays, chairside data entry and Dentrix software. Seller is retiring. Asking \$650,000.

**DUARTE GENERAL PRACTICE FOR SALE:** Twenty-three years of goodwill. Located on a corner with good visibility and signage. Seller works two and a half days per week. Average annual collections of \$395,000 with a net income of \$190,000 per year. Seller refers implants, difficult endo, difficult oral surgery and perio surgery. The office has three equipped operatories plus one additional operator that is plumbed but not equipped. The equipment is older but very functional. Motivated! Retiring. Asking \$275,000.

**BURBANK FEE FOR SERVICE PRACTICE FOR SALE:** With over 40 years of goodwill, this practice collected \$1,504,000 in 2013 and \$1,470,000 in 2014 with a net income of \$590,000 and \$625,000, respectively. Current year is on track for the same. Five days of dentistry per week plus nine days of hygienist coverage per week averaging about 100 recalls per week! Seller refers all endo, all perio surgery, all ortho, all implant placement and almost all oral surgery. No HMO, no Denti-Cal, no evenings and no weekends. Five operatories in a free standing building. Asking \$1,250,000. **-PENDING AT FULL PRICE**

**LONG BEACH FEE FOR SERVICE PRACTICE FOR SALE:** Highly desirable Naples area practice has been established at this location 37 years. Consistent collections for the past 5 years, including this year, of over \$600,000 per year (2015 is projected to be over \$650,000). Seller works four days per week with eight days of hygiene per week (2 hygienists per day). Over 1,600 patients on recall. Seller refers all endo, all perio, most oral surgery and all ortho. Five operator office in a professional building. Asking \$475,000. **-PENDING AT FULL PRICE**

**VALENCIA FEE FOR SERVICE PRACTICE FOR SALE:** Practice with 25 years of goodwill has been relocated due to a fire to a brand new office. Exceptional facility with seven year old Adec equipment, Biolase laser, digital x-ray and full computerization. State of the art tenant improvements. Seller works four days per week with two and a half days of hygiene per week. Collections have been fairly stable at \$450,000/year. Retiring. Asking \$170,000. **-SOLD**

**CARSON STARTER PRACTICE FOR SALE:** Retail location with 3 operatories and good marketing potential. This practice has been a "hobby" practice for the seller, who works just 2 1/2 days per week. The practice collects \$126,000/year with no marketing or promotion. Positive cash flow, but minimal profit. The practice needs someone that will dedicate more time and do more marketing. Seller is relocating out of state. Asking \$100,000.

**ENCINO FEE FOR SERVICE PRACTICE FOR SALE:** Quality oriented private practice has consistently collected \$1.1 million for the last four years with an equally consistent net income of over \$450,000 per year for the same four years. Seller refers all endo, all perio, all oral surgery and all ortho. Fully computerized four operator office with digital x-rays. No PPO's, no HMO's, no evenings or weekends. Health issues are creating the need to sell. Asking \$850,000. **- SOLD AT FULL PRICE**

**ANTELOPE VALLEY CAPITATION PRACTICE FOR SALE:** This practice has collected \$1.1 million each of the last three years with an average annual net income of over \$450,000. Cap checks are \$12,500/month. The practice has endo and oral surgery specialties, but no perio, pedo or ortho. The practice averages 78 new patients per month. No Denti-Cal. Profitable practice – a money maker. Asking \$828,000. **- PENDING**

**SIMI VALLEY GENERAL PRACTICE FOR SALE:** Collected over \$700,000 in the past twelve months. Good net income. 3 days of hygiene per week. 4 operator office with digital x-rays and PracticeWorks software. Ground floor of a professional building. Asking \$425,000. **-SOLD AT FULL PRICE**

**MULTI-OFFICE/MULTI-SPECIALTY PRACTICE:** Well known group practice collects \$5.5 million per year. The practice does accept Denti-Cal and is seeing revenue growth in 2015 since adding Denti-Cal to the practice. All specialties are covered. Newer modern offices. Asking \$2,700,000.

**WEST COVINA PRACTICE FOR SALE:** Starter practice with low overhead. Collected \$200,000 in 2014 and over \$100,000 for the first four months of this year. The practice is in a free standing building and has three equipped operatories plus a fourth that is plumbed but not equipped. Seller works 2-3 days per week as he has a second practice near his home in Glendale with a partner. Motivated. Asking \$100,000.

**TUJUNGA GENERAL PRACTICE FOR SALE:** Well known practice with long history and good visibility in a shopping center location collects \$820,000/year with a net income of \$340,000/year. Seller works 4.5 days per week and has 4 days of hygiene per week. Seven equipped operatories plus one additional operator that is plumbed but not presently equipped. Seller refers all endo, all perio surgery, difficult oral surgery and all ortho. No capitation and no Denti-Cal. Solid "bread and butter" practice in a relatively underserved community in Southern California. Asking \$675,000.

**SAN FERNANDO VALLEY PERIO PRACTICE:** Established perio practice collected over \$894,000 in 2014 with a net income of \$285,000/year. Hygiene accounts for 25% of the revenue. Seller works 3 1/2 days per week. The office has five equipped operatories in a professional building. The practice receives referrals from over 30 different general dentists in the community. Seller will stay for a transition if requested. Asking \$475,000. **-PENDING**

 **LEE SKARIN and ASSOCIATES, INC.**  
530 W. Stafford Road, Westlake Village, CA 91361  
800-SKARIN #1 • 805-777-7707 • Fax: 805-777-0051  
Email: lsainc@aol.com • www.LeeSkarinandAssociates.com

- Expert appraisals
- We have a large inventory of buyers
- Over \$20 million in practice sales last year

*Serving the dental profession since 1959*

# of Your Dental Practice . . .

## Timing Can Be Everything

**LEE SKARIN AND ASSOCIATES...**

**the Name Dentists have Trusted Most Since 1959.**

### 2015 TAX SAVINGS FOR BUYERS

If you have earned \$150,000 or more this year, you may want to consider purchasing a dental practice before the end of the year to dodge your income tax bullet. Most associates today have few if any deductions to offset their earned income and as such pay significant taxes, especially when compared to dentists that own their own practices. It is well known that dentists that own their own practices have greater write-offs and, generally, pay lower taxes than their associate dentist counterparts, because the tax code favors small business owners.

As an example consider the Section 179 deduction. This IRS code section applies to purchases of equipment. In 2015, the maximum Section 179 deduction that can be taken in one year is \$200,000. This means that if you purchased \$200,000 of equipment in 2015 that you can depreciate 100% of that amount against your earned income thereby getting \$200,000 of tax-free income.

Let me make it very concrete using our \$150,000 per year associate's income with no personal deductions. The combined federal and state income tax on that amount would be \$46,688.00 which would have to be paid by April 15, 2016. If the associate buys a dental practice with \$150,000 or more allocated to the equipment and closes the sale on or before December 31, 2015, the associate will pay no income tax on the \$150,000 of earnings. As the amount of earnings goes up, so do the savings as the higher income is taxed at higher rates.

To keep more of your income, call Kurt Skarin at Lee Skarin and Associates, Inc.

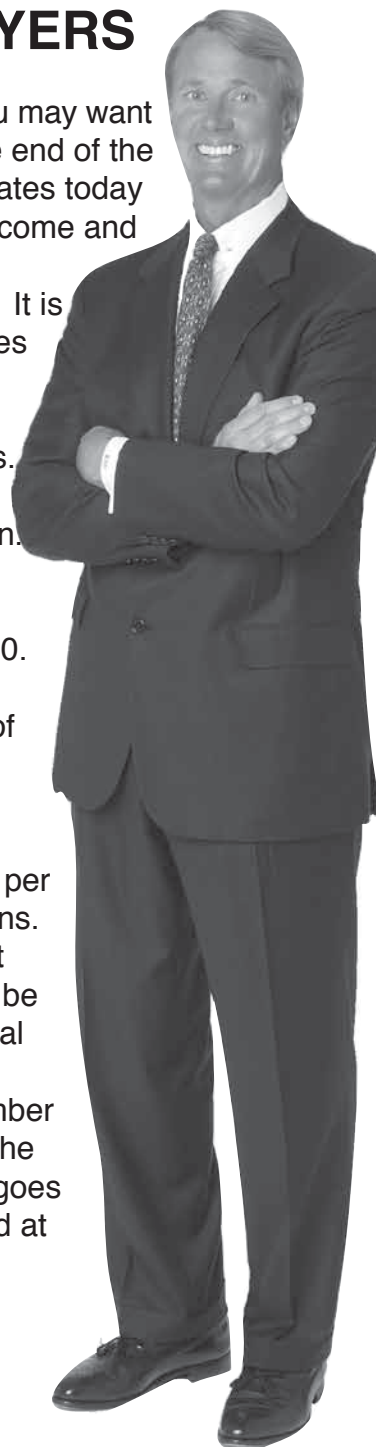

**LEE SKARIN & ASSOCIATES INC.**

CA DRE #00863149

**Call for Free Consultation! 805-777-7707 or 800-SKARIN #1 (800) 752-7461**

Place a FREE Reader Ad online at [www.thedentaltrader.com](http://www.thedentaltrader.com)

# LCF Practice Sales & Financing

Free consultations for Buyers & Sellers

**BUY PRACTICE • SELL PRACTICE • FINANCE PRACTICE**

## ATTENTION SELLERS!

We currently have **Pre-Approved Buyers** for dental practices located in **Orange County, Los Angeles, Riverside, San Fernando Valley, San Diego County and the Bay Area.**

Call to List  
Your Practice  
With Us Today!

Toll-Free:  
1.800.550.9228

### Upcoming Listings:

- Downey
- Riverside
- San Juan Capistrano

*"My relationship with LCF Practice Sales has been strong from the beginning. I have worked with Loc Pham as a buyer, seller, and as a financing client, and I have been consistently impressed with his professionalism and hard work."*

- Dr. Joel Manalese, D.D.S.

## We Offer Up to 100% Practice Financing!

- Practice Sales
- Working Capital
- Refinance/Consolidate
- Equipment Leasing
- Real Estate Acquisitions
- and So Much More!

### Dental Practice for Sale Los Angeles County, CA

#### Gardena - Busy Intersections

- Strip mall nearby anchor stores.
- High Traffic. Great Visibility.
- 4 Operatories, ~2,100 sq.ft.

#### Long Beach - Busy retail center

- Perfect location for a Starter Practice. Major anchored stores.
- Affordable Rent. ~1,000 sq.ft.
- 3 Eq. Ops + 1 add't plumbed

#### Long Beach - 20 Yrs of Goodwill

- 5 Operatories, ~1,300 sq.ft.
- Mixed Income & Stable Pt Base

#### Los Angeles - Gross ~\$400K

- Highly Visible from busy streets.
- Affordable Rent! Cash/PPO
- 3 Eq. Ops plus 2 add't chairs.

#### Los Angeles - Gross ~\$356K

- Well Known Medical Building Close to Retail/Shopping Center
- 4 Operatories, ~ 1,397 sq.ft.

#### Santa Monica - Gross ~\$300K

- Seller Retiring. Highly Visible
- 4 Equipped Ops, ~ 1,397 sq.ft.

#### South Gate - Gross ~\$150K

- Seller Retiring. Shopping Ctr.
- Excellent Visibility & Signage
- 4 Equipped Ops, ~1,200 sq.ft.

#### Valencia - Gorgeously Design

- Real Estate & Practice for Sale
- Projected Gross 2015 ~\$870K
- State of the Art Practice
- Increasing Revenue, Cash/PPO
- 6 Operatories, ~2,200 sq.ft.

### Dental Practice for Sale Fresno County, California

#### Coalinga - Freestanding Building

- Gross ~\$589K on 3-4 days/wk.
- Located on busy main street
- Excellent Visibility.
- Paperless Office.
- 3 Fully Equipped Operatories
- Approx. 1,200 sq.ft.

### Dental Practice for Sale San Diego County, CA

#### La Jolla - Gross ~\$350K

- Retail Center, digital office.
- Mostly PPO, 2 Equipped Ops.

### Dental Practice for Sale Orange County, California

#### Laguna Hills - Beautiful Office

- Projected Gross 2015 ~\$400K.
- Increasing Revenue. Cash/PPO.
- Busy Retail Shopping Center.
- 4 Eq. Ops, Approx. 1,750 sq.ft.

#### Mission Viejo - Gross ~\$1.2 Mill

- Large Shopping Center
- Mostly PPO/Stable Pt Base
- 7 Operatories, ~2,700 sq.ft.

#### Santa Ana - LOW RENT!

- Highly Visible Corner Office.
- Busy Street. High traffic
- 3 Eq. Ops, Approx. 1,100 sq.ft.

#### Santa Ana - Gross ~\$345K

- Main Street, Downtown
- Mostly Dential, ~2,392 sq.ft.
- 5 Eq Ops + 2 Add't Plumbed

### Dental Practice for Sale Riverside County, CA

#### Moreno Valley - Gross ~\$235K

- Stand Alone Building & Dental Practice for Sale
- High Visibility on Busy Street
- 4 Eq. Ops + 5 Add't Plumbed
- 2,500 sq.ft., 9-10 Parking Space

### Dental Practice for Sale San Bernardino County, CA

#### Ontario - New Listing!

- Starter Practice on busy main street. Excellent visibility.
- Seller retiring. Low Rent!
- 3 Equipped Ops, ~1,100 sq. ft.

#### San Bernardino - Starter Practice

- Asking \$25K or Best Offer!
- 1063 North D Street
- San Bernardino, CA 92410
- Private parking in the back.
- 2-3 Equipped Ops / 4 Plumbed
- Low Rent! ~1,163 sq.ft.
- No Patient Base.

### Buy Two Practices Together Dental Practices for Sale in Rialto & Rancho Cucamonga

- Practices Gross ~\$906K
- Both Dental Practices are in Large Retail Centers.
- Rialto: ~3,500 sq.ft. 8 Ops
- Rancho: ~2,100 sq.ft., 5 Ops.
- Don't Miss This Opportunity!

### Dental Practice for Sale Northern California

#### Concord - Gross ~\$125K

- Practice & Real Estate Available
- Freestanding building
- Mostly Cash/PPO. Good visibility.
- 2 Eq Ops + 2 Plumbed, 1,500 sf

#### Dublin - Gross ~\$785K

- Prime location. Shopping Center
- Mostly PPO/Cash Patients
- 5 Operatories, ~1,800 sq.ft.

#### Fremont - Gross ~\$485K

- Busy main streets, ~2,000 sf.
- 4 Eq Ops + 3 add't plumbed.

#### Gilroy - Gross ~\$243K

- Large shopping center.
- 3 Eq. Ops + 2 add't plumbed.

#### Hayward - Gross ~\$438K

- Located in shopping center.
- Mostly Cash/PPO, ~1,800 sf
- 4 Eq Ops + 1 Add't Plumbed

#### King City - Gross ~\$650K.

- Large retail shopping center.
- Over 10 Years of Goodwill
- 5 Eq Ops, ~ 1,375 sq.ft.

#### Modesto - Gross ~\$300K

- 3 days a week for past 3 years.
- Long established patients
- 4 Eq Ops + 1 Add'l plumbed

#### Modesto - Gross ~\$830K

- GP located in strip mall.
- Cash/PPO, ~ 3,200 sq. ft.
- 7 Eq Ops + 1 Add'l plumbed

#### Salinas - Gross ~\$243K

- Shopping center. Cash/PPO.
- 3 Eq. Ops + 2 add't plumbed.
- Very little competition around.

#### San Jose - Great Location

- Strip Mall. Busy Street.
- 3 Eq. Ops, Approx. 1,040 sq.ft.

#### San Jose - Stand Alone Bldg.

- Asking \$15K or Best Offer!
- Starter Practice w/ Patient Base.
- 5 Eq. Ops, Approx. 2,000 sq.ft

For our complete listings, visit us at  
[LCFPracticeSales.com](http://LCFPracticeSales.com)  
or Call Today at  
(714) 550-7494  
(800) 550-9228

Call Loc Pham, Broker (714) 550-7494 for More Information!

Email: [Practice@lcffin.com](mailto:Practice@lcffin.com) | Website: [LCFPracticeSales.com](http://LCFPracticeSales.com)

A Division of LCF Financial, Inc. BRE #01875780

# HONEST-TO-GOODNESS DENTAL EQUIPMENT REPAIR SINCE 1993



**COMPLETE DENTAL  
EQUIPMENT CHECKUP**

**ONLY  
\$95**

- ✓ Check Dental Handpieces
- ✓ Discuss Handpiece Maintenance
- ✓ Check Delivery System Functions
- ✓ Check & Adjust Delivery System Air & Water
- ✓ Check Compressor System Function, Filters & Oil
- ✓ Check Vacuum System Function
- ✓ Check Patient Chair Function
- ✓ Check Operatory Light Function
- ✓ Check Visible Plumbing for Wear and/or Leaks
- ✓ Check Sterilizers, Autoclaves, & Chemiclaves

## FREE PICKUP WITH VISIT

- ✓ Dental Hygiene & Diagnostic Instruments
- ✓ Dental Highspeeds & Lowspeeds
- ✓ Cavitrons & Curing Lights
- ✓ Dental Sterilizers

**REPAIRMAKERS**  
DENTAL EQUIPMENT REPAIR PROS

Schedule Service 877.535.1733  
[www.repairmakers.com](http://www.repairmakers.com)



**DANA POINT** Exceptional Opportunity in a 3 OP Fee for Service Practice. 2014 Gross \$583,277 with adjusted net of \$221,000. 33 years goodwill. holocker@yahoo.com.

**Ready to build** your dream practice? Allow Live Oak Bank to finance your construction project with up to 100% financing. 877.890.5867 [www.liveoakbank.com/healthcare](http://www.liveoakbank.com/healthcare).

**Dental practice** for sell in El Monte Strip Mall High visibility, 850 sq. ft. low rent, 4 ops. for pictures and details. carldasilva26@aol.com,(909)255-4008.

**Intraoral Cameras** with premium warranty and lifetime support on SALE NOW! See color flier in this issue for details. [www.Lensiora.com](http://www.Lensiora.com).

**PRACTICE FOR SALE** El Monte CA, 4 OPS. 850 sq ft. strip Mall, high visibility and low rent. For details and pictures, call: (909)255-4008, or [carldasilva26@gmail.com](mailto:carldasilva26@gmail.com).

**CAVITRON ULTRASONIC SCALER** (Select SPS 30k) (#81302) & Reservoir Pump (#90146) Like New, Original Cost \$2,758, Make Offer 855-772-7645 [janetm@hygiacare.com](mailto:janetm@hygiacare.com).

**Canoga Park** PT position for GP. Base & Bonus. Spanish speaking is a plus. email resume to [nazsoffice2000@yahoo.com](mailto:nazsoffice2000@yahoo.com) or fax (818)883-9781.

**PRACTICE FOR SALE** POWAY GP w/ 20 yrs gdwll in 1,240 sqft ste Proj approx \$188K. California Practice Sales, Inc. Phone: 714-639-2775.

**AMY L. BORDEN, ESQ., APC** "I saved over \$20,000. Ms. Borden reviewed my commercial lease agreement and was able to extend the lease term and secure a rent reduction which saved me over \$20,000 over the life of the lease." Dr. Giri Palani, President, Total Smile Care. [www.californiadentalattorney.com](http://www.californiadentalattorney.com).

**8 chairs** doctor and assistant chairs. \$250 for all. used good condition. 949-661-6255 ask for roberta.

**Dental Instruments** New or like new Rubber Dam Punches (6 -all Hu-Friedy) Clamp Removers (12) Cotton pliers (5)(323) 851-6622.

**Seeking Dentist** w/experience for our Upland & Rancho Cucamonga offices. Please email [contact@DrEmilyOrtho.com](mailto:contact@DrEmilyOrtho.com) if interested.

**RDA needed** for friendly Glendora office. Motivated team-player a must! Email resume to [sandimasdental@gmail.com](mailto:sandimasdental@gmail.com).

**GREATER LOS ANGELES** Perio Practice, 5 Ops, Dentrax, Digital, Laser est. over 34 years with long-term staff. HSPPT-Kerri McCullough 949-566-3056-#CA173.

**Elegant dental space** avail. Ocean view. 6 operatories. Some pt referrals for specialists. Free parking 1 blk away email: [meflsc@aol.com](mailto:meflsc@aol.com).

**Look for your free** wall-hanging color calendar in this edition... compliments of The Dental Trader Advertisers!

www.dental-attorney.com

# My Law Firm is Nothing Without You!



Levi Barlavi, Principal of the Pacific Health Law Group

**Toll Free: (888) 995-5384**

## Legal Services *for* Dentists

- Practice Acquisitions/Sales
- Lease Reviews & Negotiations
- Professional Corps & Partnerships
- Employment Law Matters
- Space Sharing Agreements
- Dispute Resolution/Litigation

*"I would like to recommend Levi Barlavi for his excellent work, customer service and reasonable price point. Over 6 months ago, Levi provided me with the BEST legal help as I purchased my very first dental practice. He was instrumental in advising me about setting up my corporation and also reviewing the most important legal documents relating to my practice. I would not hesitate to work with Levi in the future and I have already recommended him to all my friends who are considering starting a corporation or buying a practice."*

*-Melanie Marshall, DDS*

*"Dr. Marshall, it was a pleasure to represent you in your transaction. Thank you for your trust in my practice. My law firm is nothing without clients like you. I never forget this point! I look forward to your continued success."*

*-Levi Barlavi, Esq.*

As an attorney specializing in meeting the legal needs of dentists throughout California, I have a simple goal: **to add value to your practice.** I accomplish this by being accessible, thorough and placing my client's needs first. I am committed to client service because I know it is what you want, and what will secure your return business and referrals. That is the greatest compliment! If you want to like your attorney in addition to receiving thorough legal work please call me today for a free consultation. Let me earn your trust.



Los Angeles | San Diego  
www.dental-attorney.com

**Protecting Your Investment, So You Can Grow Your Practice.**

**DENTAL PRACTICES WANTED** in OC and LA County Gross 400K+. Strip mall, anchored business. Sellers call Loc Pham, Broker at LCF Financial, Inc. BRE#01875780. (714)550-7494 or practice@lcffin.com | LCFPracticeSales.com.

**Thank you** for helping me and making the process so easy for me. – Safa Khaleel DDS, Mountain View, CA. www.TheDoctorsInsuranceBroker.com.

**Dental office** in OC hiring. Must currently work in office that DOESN'T do Ortho. Pays-well. Send resume to Ortho888@gmail.com.

**FREE PHONE CONSULTATION AND GUIDANCE FROM THE LEADING DENTAL ATTORNEYS IN THE COUNTRY?** What do you have to lose? CALL TODAY 800-499-1474 WOOD & DELGADO www.dentalattorneys.com.

**Beverly Hills Office** For Sale. 2 Mil+ collections. Priced to sell as Dr retiring. Serious buyers only. toothdocla@gmail.com.

**OXNARD** (4) op comput. G.P. for sale. Located in a prof. bldg. with ample free parking. Dentrix s/w & digital x-rays. 2014 Gross Collect \$264K+ on a (3) day week. Cash/Ins/PPO/HMO/Denti-Cal pts. Seller refers diff. Endo & O.S., all Perio & Ortho. & does no advertising. Seller taking non profit position. D&M Practice Sales 818.591.1401.

**Immediate opening** for a marketer in La Puente .Great compensation. previous experience needed. please email: as7067@gmail.com.

**SKYROCKET YOUR PRODUCTION!** Specialty services in your office by highly experienced GP. Implants with abutment: \$450, Molar RCT's and Retreatments: \$350, Surgical extractions with bone graft: \$200, Sinus lifts with implant and abutment: \$650. LA County. Call or Text: (310) 703-2636.

**DENTIST/P/T-F/T** needed for a busy office located in the San Gabriel Valley. 3 years experienced on all phases of dentistry including endo on molars and extractions. Fax resume 626-575-0240 or e mail alfonsoem1935@gmail.com.

**WHY A DENTAL CPA?** Call 714-259-0505 Wiederman & Chamberlain, CPA.

**DENTAL ASSISTANT NEEDED** ANAHEIM, PART TIME: front/back office, x-ray license, English/Spanish. Call: (714) 319-4956.

**LOS ANGELES PRACTICE FOR SALE** Dr. retiring after 44 years - 3 operatories in approximately 1200 sq. ft - very modern with digital x-rays — days hygiene/week - grosses approx. \$400,000 on 4 easy days/week – 2 days hygiene - Thomas & Fees Practice Sales (714) 544-4341.

**Dentist needed** Female dentist needed in Oxnard 2-3 days a week. Spanish speaker preferred. Please email to manvelano@yahoo.com. or 818-378-8202.

**Attention all Dental offices Pediatric Dentists, Orthodontists, Perio and Endo specialists are using www.upsurg.com to find work.**



**The Dental Trader**  
wishes you a  
very Merry Christmas,  
Happy Holidays  
and a Happy New Year!

**TINA OCHOA** DENTAL BROKER WITH 23 YEARS EXPERIENCE IN THE INDUSTRY "WHEN EXPERIENCE MATTERS" BRE# 1049085 (951) 309-3196.

**SURGERY DONE IN YOUR OFFICE** IMPLANTS, EXTRACTIONS, PERIOSURGERY. GENTLE & WITH MANY RECOMMENDATIONS. (626)447-0888. KEEP THE PRODUCTION IN YOUR OFFICE.

**PRACTICE FOR SALE** SAN LUIS OBISPO COUNTY Beautiful off. w/ 6 ops; Net \$370K. California Practice Sales, Inc. Phone: 714-639-2775.

**Caring dentist** to treat our patients in San Diego. Must be competent with molar endo. E-mail resume to DRNGUYEN@LASERIMPLANTDENTAL.COM.

**HACIENDA HEIGHTS** General Dentistry, 5 Ops, 3 Equipped, busy retail center. 2014 GR \$494K. HSPPT-Steve Caudill 951-314-5542-#CA295.

**General dental office** (PPO/Fee For Service) in search of an Endodontist for 1-2 days/month. Send resume to LauraBucciDDS@hotmail.com.

**INTRAORAL CAMERA** (2)-Magenta MD960U, Like New, Original Cost \$249 each, Make Offer 855-772-7645 or janetm@hygiacare.com.

**PT General Dentist** needed for Irvine Office. Fri, Sat (flexible Schedule) Please send resume to staff@irvinesmilearts.com or fax(949)726-1002.

# YEAR END

## Vacuum Pumps - 1 HP

**\$1696 / \$1295**

*3 Available*



The Precision 1 Horsepower Vacuum System is engineered with Naval Brass and Warranted for 5 Years. It is available in 120v or 240v and easily installs in Any Dental Office. A cost effective solution for a "Back Up" system.

## Oil Less Air Compressor - 1 HP

**\$3295 / \$2795**

*2 Available*



The Clean Flow 1 Horsepower Oil Less Air Compressor is outfitted with a Complete Air Drying System and Air Intake System. It will easily deliver clean dry air to 4 - 5 operatories and it manufactured in the USA. It comes with a 5 year warranty.

## Oil Less Air Compressor - 2 HP Dual

**\$4295 / \$3795**

*2 Available*

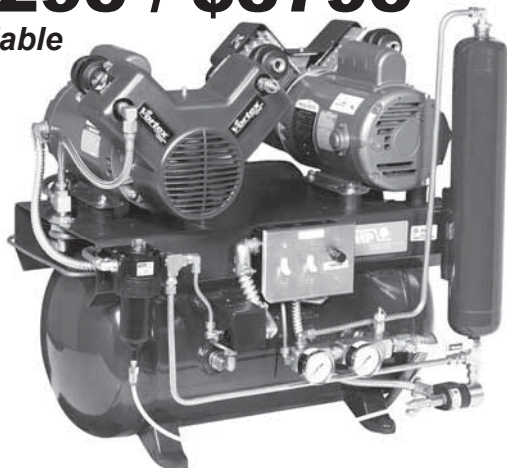

The Clean Flow 2 Horsepower Dual Motor Oil Less Air Compressor is outfitted with a Complete Air Drying System and Air Intake System. The dentist can choose to operate either Oil Less Motor or can use both to supply clean dry air to as many as 10 operatories it manufactured in the USA. It comes with a 5 year warranty.

## Vacuum Pump - 2 HP Dual Motors

**\$3495 / \$2895**

*3 Available*

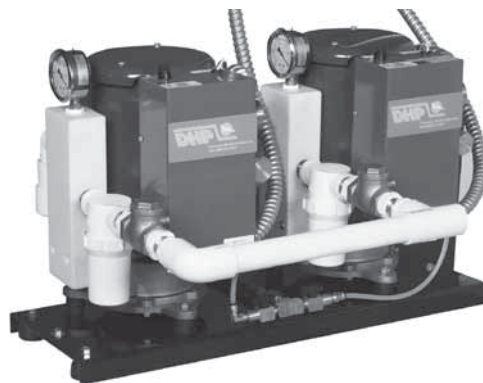

The Precision 2 Horsepower Dual System is designed so the dentist can use either of the Vacuum Pumps or use them in conjunction and create a powerful dual motor Vacuum to ensure quality intraoral evacuation. They are Made in USA and come with a 10 Year Warranty.

# Dansereau Dental



# BLOW OUT!

## Diamond Dental Light

**\$895 - \$595**

5 Available

Quality Dental Light with High and Low Features, installs on Any Dental Chair.

Halogen light with adjustable light pattern and non drifting dental light arm are integrated in the Diamond Dental Light.



*All this equipment is new and fully warrantied.*

## Roadrunner "Hybrid" Dry Vacuum System

**\$5295 / \$4295**

3 available



## Infinity LED Dental Light

**\$1595 / \$795**

7 Available

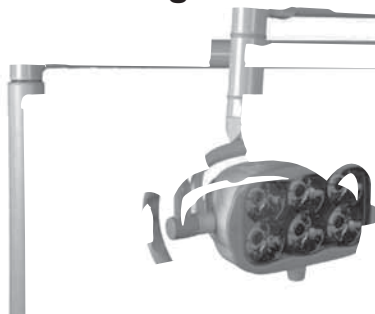

LED Dental Light with a Cool Light Source, Adjustable Illumination installs on Any Dental Chair. The Infinity Dental Light includes 3 way articulating light head and true natural lighting to reduce eye fatigue and reduce or eliminate quick curing of bonding materials.

## Infinity Delivery System with Asst Package

**\$2595 / \$1895**

4 Available

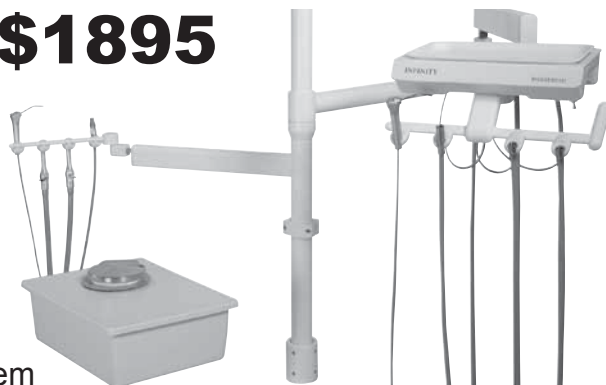

Upgrade your Old Tired Delivery System with a New Delivery System, Complete with 3 Handpiece Automatic Unit and 3 Way Syringe. All mounted on Air Locking Flex Arm. The Telescoping Assistants Package includes a 3 Way Syringe, 2 HVE and 1 Saliva Ejector and the Complete Dental Junction Box. It will mount on Any Dental Chair and comes with the confidence of an American Manufacture Product with a 10 year Warranty.

The Roadrunner Dry Vacuum System is truly a "Hybrid" with the combination of the variable speed operation, a "Real Time" sensor increase vacuum as needed by the dentists use, and the non use of water in the vacuum system it will reflect in short term and long terms savings for the dentist.

**MADE IN THE USA**

Phone: (800) 423-5657

Website: [WWW.DHPDENTAL.COM](http://WWW.DHPDENTAL.COM) • Email: [Harry@DHPDENTAL.COM](mailto:Harry@DHPDENTAL.COM)

# A Different Kind of Dental Attorney

*I know dentistry's unique legal & financial challenges*

## Services

Incorporation  
Estate Planning  
Buy/Sell Agreements  
Lease Reviews  
Space Sharing  
Agreements  
Workers' Compensation  
Practice Sales

**Call us  
for other services!**

## Member

CA State Bar  
NC State Bar  
US Federal Courts  
US Federal Tax Courts  
Calif. Dental Licensure

## *Testimonials:*

*Jeng and Associates have represented me in buying 3 offices and multiple lease reviews and negotiations. Their professionalism is unbeatable and Dr Jeng is always available to answer my questions by phone or email.*

Dr. L. Kong, Daly City, Ca

*I highly recommend Dr Jeng as a dental attorney. His experience as a dentist combined with his legal experience gave me the confidence to enter into a share office arrangement. He was always available to answer my calls and addressed all my concerns and questions.*

Dr. P Tran, Burbank, Ca

*Dr. Chester Jeng represented me in my last two dental office purchases. Very professional and helpful. He is my go to lawyer for my legal needs.*

Dr. K Chou, Hacienda Heights, Ca



## Law Offices of Jeng and Associates Chester Jeng, DDS, JD, LL.M

Cell: (909) 450-7158 • (714) 858-0536  
Jenglaw.com • Jenglaw@yahoo.com

1440 North Harbor Blvd., Suite 900, Fullerton, Ca. 92835

\*Disclaimer: Monthly tip is not legal advice and in no way attorney-client privilege has been created. Consult a CPA or attorney if you need tax or legal advice.

**Dental Assistants** needed in Sunnyvale for high volume children's dentistry. Full time + benefits. Send resume to: dtresume@cdgdental.com.

**PERIODONTIST/GENERAL DENTIST** with oral sedation needed PT in Santa Ana office. Base salary + commission. Please send resume to tommycledds@gmail.com.

**\$4995** American Manufactured Dry Vacuum System \$1000 Cash Rebate or 36 Month No Interest Financing OAC. Call (800) 423 - 5657 or visit DHPDENTAL.COM for more details.

**DentiMax Dream Sensors** Try before you buy. Test our award winning sensor in the comfort of your own practice without any obligation. Call 1(800)397-6046.

**Calling all Dental specialists! Dental offices are now using UpSurg to find a dental specialist. www.upsurg.com.**

**Searching for the right bank?** Look no further than Live Oak Bank. Our lenders understand your business and specific financing needs. 877.890.5867 www.liveoakbank.com/healthcare.

**dentist wanted** with pedo experience for busy pedo office in hemet California full or part time reach us at dentistry4kd@gmail.com.

**SAN BERNARDINO** by the University, 4 ops., 3 equipped, Dentist retiring with 20 years of goodwill. Great price! Great potential! iepracticesales.com (951) 816-6242.

**\$550** Handler Bench top polishing system (#575) Lathe not included. Email me for details Davinci0163@gmail.com.

**Board Certified Mobile Dental Anesthesiologist for sedation and general anesthesia cases in-office. Pediatric and adult cases. Professional and supplies own equipment. Call (949)288-3401.**

**Dental Assistant** P/T needed in Burbank Please email CVT to dentistsassociates@gmail.com.

**Litigation** is the new retirement plan...if you find yourself placed in a defensive position, call Kerendian & Associates. We'll protect you. Call Kerendian & Associates 888-299-7848.

**PICO RIVERA** General Practice, 6 Ops, Pano. 4½ days of hygiene per week. 2014 GR \$690K. HSPPT-Thinh Tran 949-533-8308 #CA258.

**Global dental microscope** Excellent condition Floor stand. G4. Carr extender. LED. Camera/video capable. Dental composite filter. \$20K. Call 6192411979.

**It was a great pleasure** to work with All County Construction a very professional company that listens to me. Dr. F Tacharina. 714-240-7179.

**ANESTHESIOLOGIST** Dentist Anesthesiologist serving your Central Coast office SLO to Camarillo. Competitive Rates. Wednesdays or Saturdays available currently. 630-723-1946. erikdwinn@hotmail.com.

**\$\$\$\$\$\$ NEED MONEY FAST?** Sunwest Bank can close your dental practice deal quickly. Call 714-730-4412.

**orthodontic model box** (4 compartments, hold 2 sets of models ) used, paid 90 cents each new, now 20 cents.626-285-5800.

**Failed molar** Endo, Need Apicoectomy, broken file? No worries. Call me, I come to you. 562-968-4061 www.socalrootcanal.com.

**New Gendex** GXC300 intraoral camera. Retail \$3789. Comes with case, sheathes, software driver and user manual. \$3000 OBO. Call 858-531-5410.

**WINE N DINE AFTER A LONG DAY AT WORK** Temecula – GP 1 large exam room. ID#CA76595. Call Maria at Practice Concepts 877-778-2020 x. 108.

**Periodontist needed** city of Ventura. Owner is a prosthodontist, multi-specialty group. Cone-Beam, surgical room, I.V. available. Must be willing to sign-up with HMO & PPO plans. Compensation format: Percentage of collections. E-mail resume Venturadds@aol.com or Fax: (805)676-1521.

**SAN DIEGO PRACTICE SALES** Looking to BUY or SELL a practice in San Diego County?? Call the area experts for prompt personal service with integrity. We can also assist you with PRACTICE APPRAISALS, BUY-IN/BUY-OUT TRANSACTIONS, and LEASE NEGOTIATIONS. Call for complimentary consultation. 760-599-7828.

**Intraoral Cameras ANNUAL SALE!** Buy 2 for \$1664 with warranty and lifetime tech support. Use PROMO code TRADER on www.Lensiora.com.

**Brand new** Dynamix speed 66045802 ( henry schien \$2300.00) ask for 1500.00 OBO, call 562 328 3626 Dr. Lee.

**Listed, Advertised** and an Accepted Offer in 17 days – Greg Beamer, Dental Broker 909-542-4891.

**LOOKING FOR DA** IN CORONA CA 2 YEARS EXPERIENCE CALL, TEXT OR FAX (951)279-2700, (951)279-0616.

**FACT** In dentistry your **HEALTH** is your **WEALTH...Is your income & family protected?!?! Call for a FREE Disability Insurance Appraisal 855-346-9729 di4dds.com.**

**In-Office Equipment Repair** 50% OFF FIRST HOUR Friendly. Prompt. Professional. Honest. Contact Us Today! 877-535-1733 / www.repairmakers.com.

**PRACTICE FOR SALE** PALM SPRINGS GP in free standing bldg NET \$175K. California Practice Sales, Inc. Phone: 714-639-2775.

**SANTA BARBARA** General Practice, 4 Ops, 8 days of hygiene/week, long-term staff. 2014 GR \$827K. HSPPT-Kerri McCullough 949-566-3056 #CA291.

**General Dental office** space available to share in San Juan Capistrano. 3 ops with pan, digital x-rays. checkmyteeth@yahoo.com.

REAL ESTATE | ACQUISITION | EXPANSION | NEW CONSTRUCTION | REFINANCE | START UP

# WE'VE GOT YOUR BACK, FROM BREAKING GROUND TO FINAL BRICK.



With financing designed to preserve your cash, you can get started on your new office today.

Let your Dental focused lending team and dedicated construction team carry the weight. Contact one of our lenders to get started.



JP Blevins  
General Manager  
910.796.1674



Mike Stanton  
Loan Officer  
404.995.2003



Mike Montgomery  
Loan Officer  
910.798.1215



Lindsay Harkey  
Loan Officer  
910.550.2277



**LIVE OAK BANK**  
liveoakbank.com

Visit [liveoakbank.com/dental-trader](http://liveoakbank.com/dental-trader) for your free guide to "Managing Your Financial Profile"

©2015 Live Oak Banking Company. All rights reserved. Member FDIC

**Asst Stool for sale** barely used, adj height/ foot ring, sell \$80. (562)430-1013 or info@mydiamonddental.com.

**LICENSED FEMALE DDS** SEEKING HYGIENE POSITION IN SFV: friendly, trustworthy, team player. Contact gmbdds@gmail.com.

**Thomas Sudbijo, DMD** (Tustin, CA)-Law Offices of Jeng and Associates is definitely one law firm that I will continue to use for my legal needs. Dr. Jeng was very helpful addressing my questions and was on top of things and kept me informed in every step. Call Jeng & Associates 714-858-0536.

**Dental practice** for sell in El Monte Strip Mall High visibility, 850 sq. ft. low rent, 4 ops. for pictures and details. cardasilva26@aol.com, (909)255-4008.

**SAN LUIS OBISPO** Perio practice. 4 ops. Upscale equipment. Purchase the full practice or half. IntegrityPracticeSales.com, Broker Bill Kimball, DDS, BRE #01911548. (855) 337-4337.

**El Monte 3 operatories, Located in an Open Shopping Mall with signage and ample free parking. Low rent and overhead office. Price below build out cost. Doctor Retiring/ moving out of the area. E-mail me for more information: valleymalldental@aol.com.**

**100% Demineralized Bone Matrix Putty** in a syringe .07cc \$85.00 1.0cc \$125.00- these prices can't be beat www.dentalprodx.com.

**LOOKING TO BUY PRACTICE IN STUDIO CITY.** ALL OPTIONS CONSIDERED. PLEASE EMAIL: mydds@outlook.com.

**SANTA ANA** Absentee owned (6) op fully eqt'd G.P. for sale. First floor street front location on a main thoroughfare. Exposure/visibility/signage. Cash/Ins/PPO pts. No HMO & no Denti-Cal. Computerized & Pano eqt'd. 2014 Gross Collect. of \$529K+ on a (3½) to (4) day Associate run week. D&M Practice Sales 818.591.1401.

**\*\*DENTIST needed** in LONG BEACH. Must be a Denti-Cal provider, minimum one-year experience. High pay, bonus. Email resume to anthonyhungcao@gmail.com.

**DENTAL PRACTICES WANTED** in Union City, Newark, Castro Valley. Good location. Active patient charts. Sellers call Loc Pham, Broker at LCF Financial, Inc. BRE#01875780. (714)550-7494 or practice@lcfinc.com | LCFPracticeSales.com.

**Legal Tip** Fictitious business names are not permitted as a dental corporation's name. Attorney Robert W. Olson, Jr., 805.963.1120, www.transdental.com.

**ORTHO RDA WANTED** Fun Christian based Ortho office seeking Ortho RDA in Redlands Ca. Send resume to braces@paulsonortho.com.

**DENTAL OFFICE LEASEHOLDS SALE** CORONA. Sale of equipment/leasehold improvements. Great location in busy retail center, supermarket anchor, near freeway access. DentiCal ready. 5 Ops. Room for 5 ortho chairs. Recently renovated. Broker - Charles Kim 800-416-2055.

## HOW REFRESHING



*"Amy Borden assisted me in the sale of my California dental practice and purchase of my new Utah practice. Amy listened to me and carried out my wishes. Both transactions went smoothly and were completed on time. Amy is a competent, accessible and affordable attorney. Give her a call! You'll quickly see how refreshingly different she is."*

Paul A. Peterson, D.D.S.

### Flat Rate Services include:

- Buy-Sell Agreements (practice acquisition)
- Associateships/Partnerships
- Formation of Corporation
- Lease agreement review/negotiation
- Contract drafting/review
- Space sharing agreements

*Call for a complimentary consultation*

**Amy L. Borden, Esq., A.P.C.**

**888-416-1321**

**californiadentalattorney.com**

**amy@californiadentalattorney.com**

*Dedicated to serving dental professionals*



We bring specialists to you.



## Stop referring your production away

- O.S., Endo, Perio, Ortho, and Pedo
- Innovative complimentary guidance and training make transitioning a breeze
- Insurance credentialing and guidance
- Specialists will bring their own equipment including surgical kits, implants motors, endo units, and instruments



Contact us today 855-796-7374

[www.synergyspecialists.com](http://www.synergyspecialists.com) | [info@synergyspecialists.com](mailto:info@synergyspecialists.com)

**Traveling Orthodontist** Orthodontist available locum tenens and part-time, perfect for vacation or adding ortho to your general practice. travelorthodontist@hotmail.com.

**Purchasing** your new practice, call Bob Affleck @ Citi Practice Finance he will be your biggest advocate 949-939-4550.

**Spanish speaking** dentist needed for Tuesday, Wednesday and Saturday Pomona area. Please fax resume to 909-992-3380.

**Our latest SoCal course** series includes 6 Courses: Endo, Pedo, Hands-on Oral Surgery, Mandatory Infection Control, Restorative Dentistry and More, 42 CE units, all on Sundays, for only \$599! Visit [www.xcelseminars.com](http://www.xcelseminars.com) for info.

**experienced and friendly** dentist looking for a part time position with an option to buy out 8183264684.

**GP** 5 yr exp seeking an associate position leading to partnership in a PPO/FFS office. Great communication/clinical skills. dr.lcassaad@gmail.com.

**DENTAL PRACTICES WANTED** IN ALL AREAS FOR QUALIFIED BUYERS Sellers consider these benefits: NO long term Listing Agreements NO need to pay high Broker commissions BRE #1049085 (951) 309-3196.

**General dentist needed** city of Ventura. Owner is a prosthodontist. Must be high quality oriented with excellent people skills and willing to do hygiene. E-mail resume VenturaDDS@aol.com or Fax (805)676-1521.

**ESCONDIDO** General Practice, 4 Ops, 3 Equipped, est. 40 years, prof. building. Great opportunity to grow/merge. HSPPT-Russell Okihara 619-694-7077.

**GENERAL DENTIST** two or more days a weeks, Beverly Hills, fees and days negotiable, email C.V. to drdardashti@yahoo.com.

**Dental office** in Westlake Village is looking for a dental assistant. Send resume georgiandental@gmail.com, fax 818-991-4665 Great communication skills required.

**State Of The Art New Practice Construction-Experienced Licensed Contractor! Will Beat Any Written Estimate By 10%! Email Practicecoaching@gmail.com Call 213-256-1150.**

**Prevent associate** employment issues. A strong associate contract will establish the guidelines for a smooth working relationship. Free Consultation. (310) 776-5384 [www.dental-attorney.com](http://www.dental-attorney.com).

**Pedodontist needed** once a month for our 2 locations. email dr.sams@sbcglobal.net or call 714-334-4808.

**Associate General Dentist** needed in Valencia, CA for upscale private practice. Need long term commitment. Send resume to tamjag@aol.com.

**Mission Valley** High production/High profit office. Great location in busy shopping center. Freeway close. Ken Rubin Practice Sales (619) 299-6161.

# CONSUMER

# ALERT!

## The Dental Trader

**refuses to do business with the following companies:**

### AMERICAN BUSINESS CARD

aka: Bizcard.com

(A CEG Company)

P.O. Box 15190

Scottsdale, AZ 85267

[www.americanbusinesscard.com](http://www.americanbusinesscard.com)

Ph: 800-555-2234 Fax: 800-500-4506

### PROFESSIONAL FINANCING INC.

Alexander Slepak

20371 Irvine Avenue, #100

Newport Beach, CA 92707

[www.professionalfinancing.net](http://www.professionalfinancing.net)

doctor@professionalfinancing.net

Ph: 323-272-3543 Fax: 480-948-0082

*This notice is based on the advertisers' contractual lack of performance and/or legal action/court judgments.*

*If you have had a problem with these or any other Dental Trader advertiser, please send your formal complaint to:*

The Dental Trader

Attn: Complaints

Post Office Box 2631

Capistrano Beach, CA 92624

Fax: 949-498-1198

Email: [tradestaff@cox.net](mailto:tradestaff@cox.net)

*Be sure to include any relevant documentation concerning your complaint*

Mention this ad and get half off your closing costs.<sup>†</sup> Offer ends December 31, 2015.



Practice Sales and Acquisition | Start-ups | Debt Consolidation  
Deposits | Practice Relocations | Equipment and Consulting Financing  
Merchant Services | Payroll and Cash Management | Small Business Card

## Flexible financing meets important insights

2013 & 2014 Townie Choice Award Winner for Best Practice and Equipment Financing

With Bank of America Practice Solutions, you get financing\* and guidance that matches your needs

Over the years, we've helped thousands of dental practices become more efficient, productive and successful. We'll sit down with you, ask lots of questions and ensure that we totally understand your needs. Then, we'll develop a financial package that's customized to your practice.

Call now and we'll give you a **complimentary Dental Practice Business Plan** that can be invaluable to your business.



### Let's talk



Matthew Christie – 949.794.7440  
matthew.christie@bankofamerica.com

*Practice sales and acquisition*



Ali Karjoo – 949.794.7447  
ali.karjoo@bankofamerica.com

*Start-up, commercial real-estate and construction projects*

To learn more, visit [bankofamerica.com/practicesolutions](http://bankofamerica.com/practicesolutions)



**Practice Solutions**

**Bank of America** 

<sup>§</sup> CDA stands for California Dental Association.

<sup>†</sup> This offer does not include commercial real estate products.

\* All programs subject to credit approval and loan amounts are subject to creditworthiness. Some restrictions may apply. The term, amount, interest rate and repayment schedule for your loan, and any product features, including interest rate locks, may vary depending on your creditworthiness and on the type, amount and collateral for your loan. Bank of America Practice Solutions may prohibit use of an account to pay off or pay down another Bank of America account. Bank of America is a registered trademark of Bank of America Corporation. Bank of America Practice Solutions is a division of Bank of America, N.A.

©2015 Bank of America Corporation | ARMYKXPM | Rev 05/15



# Unhappy with your Health Insurance? Open Enrollment is here!

If you are unhappy with your current health plan, you have the option to change it, but only during Open Enrollment. November 1st is the first day to enroll to obtain health care for the 2016 year. Open Enrollment will end on January 31st, 2016. You only have this opportunity once per year! Also, if you are uninsured, this is your chance to enroll!

**For a free online quote visit our website:**

[www.tdibroker.com/healthquotes](http://www.tdibroker.com/healthquotes)

**Questions? Email our health insurance expert!**

[ashley@tdibroker.com](mailto:ashley@tdibroker.com)

**Call Today: 800-767-0864**



## THE DOCTORS INSURANCE BROKER™



*"Thank you for helping us with getting the right coverage!  
So many choices!"*

**-Dr. Todd Brilliant and family**

**ExoDentist needed** must be able to extract all cases. please email or text/call. 714-334-4808 or [dr.sams@sbcglobal.net](mailto:dr.sams@sbcglobal.net).

**DENTAL PRACTICE FOR SALE** PALMDALE: Retiree. 20+ years of Goodwill. HMO income of \$5K/mo. Priced Right. Call Broker - Practice Sales & Appraisals (818) 999-9595.

**"Pat, Thank you** so much for your work and advice. I'd highly recommend you to anyone!" CLINT MARTIN, DMD Wyoming, Illinois. CALL TODAY 800-499-1474 WOOD & DELGADO [www.dentalattorneys.com](http://www.dentalattorneys.com).

**Looking for an orthodontist** for our practice-please call Judy at 310-785-0770.

**ULTRASONIC** (PATTERSON PA-4) Like New, Original Cost \$450, Make Offer. 855-772-7645 or [janetm@hygiacare.com](mailto:janetm@hygiacare.com).

**Orthodontist** looking for space for rent in specialty office in North San Diego County call 646-334-0100.

**PRACTICE FOR SALE** PALM DESERT Modern designed GP w/ 5 ops NET \$361K. California Practice Sales, Inc. Phone: 714-639-2775.

**Dentist needed** A busy practice in Palmdale seeking energetic and experienced dentist email us at [avsmiles@yahoo.com](mailto:avsmiles@yahoo.com) ft/pt.

**Practice Management Software** 10% off any Practice Management purchase. Offer expires December 31, 2015. Call 1 (800)397-6046.

**PRACTICE & BUILDING FOR SALE** LA MESA. 5 equipped Ops in 2700 sq.ft. Digital X-rays and Pan. SDPS: 760-599-7828.

**Modern & mobile websites perfected for Dentists. TheDocSites.com \$0 Set Up For Dental Trader Readers! Risk Free! Limited Time Offer. 818-616-3919.**

**Office sublease** in Whittier. Digital x-rays. Flat screen monitors. only \$250 per day. Includes scheduling service. [www.exceptionaldds.com](http://www.exceptionaldds.com) 9495100225.

**WHITTIER PEDO** 4 eq. chairs in an open bay & 2 treatment rooms - Greg Beamer, 909-542-4891.

**I want to express** my gratitude for the excellent work you have done. Your work has been exceptional. - Kareem Abraham, DDS, Santa Ana, CA. [www.TheDoctorsInsuranceBroker.com](http://www.TheDoctorsInsuranceBroker.com)

**Newport Beach** 2 beautiful operatories for sublease. Perfect for new grads/starters. Flexible terms. contact [Behnamlaw@yahoo.com](mailto:Behnamlaw@yahoo.com).

**periodontis and implant** 2 day a month certify, Ontario area [ontariofamilydentistry@gmail.com](mailto:ontariofamilydentistry@gmail.com).

**Want to build a thriving practice?** Call Wells Fargo Practice Finance for a complimentary consultation today, at 1-888-937-2321.

**BOARD CERTIFIED ORAL SURGEON** 10+ yrs experience. Available in So Cal Area, willing to travel, willing to work weekends. 909-908-9660.



# CALIFORNIA

## Specializing in the Selling

### Sellers:

We have buyers looking for practices throughout Southern California!  
Call John & Bob today for your **Free Personal Sales Analysis**

**Robert A. Palumbo**  
Partner  
Executive Vice President



### Buyers:

We have 3 professional Broker/Agents to assist you in understanding how to purchase a dental office.  
Call for your **1 on 1 Consultation**

**John W. Knipf**  
President

## FEATURED LISTINGS

**GLENDALE (GP)** - Corner location only minutes away from the Rose Bowl and the popular shopping mall, the Americana. The great location with excellent visibility and signage will help continue the growing trend of this practice. The practice consists of 3 equipped operatories with 1 plumbed not equipped in consultation room. It's computerized with Practice Management software and Digital X-ray. Seller works 4 days/wk and Associate 2 days/wk. Sees approximately, 10-16 patients/day. Insurance and cash only. No HMO. Does minimal advertising. Projecting approximately \$522K for 2015. **BUYER'S NET OF \$244K.** Please contact your CPS Agent for more information. **Property ID #5045.**

**NEWPORT BEACH** - This general practice established in 2002 and is located in a 2 story medical building near residential area. Building is being remodeled and will be completed in January 2016. Seller is currently working 4 days/wk, Associate when needed and with 3 days/wk of hygiene. Sees approximately 15 new patients/mo. PPO & Cash only. No HMO. Does minimal advertising. Practice consists of 6 fully equipped operatories and 1 plumbed not equipped in a 1,956 rentable sq ft suite. It's computerized with Easy Dental software and digital x-ray (1 sensor). Projecting approximately \$643,160 for 2015 with a Buyer's Net of \$168,685. Great practice. Please contact your CPS Agent for more details. **Property #5086.**

**POWAY** - General practice with over 20 years of goodwill is located in a one story building. Currently the Seller is working 4 days/wk and sees approximately 5-10 new patients/mo. PPO and Cash Only. Practice consists of 2 equipped operatories and 1 plumbed not equipped in a 1,240 sq ft suite. Does minimal advertising. Projecting approximately \$185K for 2015. Seller will be retiring. Great opportunity for a starter practice or for an experienced dentist with a vision to expand. Please contact your CPS Agent for more details. **Property ID #5084.**

**RIVERSIDE GP + 2 Buildings** - Established in 1996 this modern designed practice is located in a 2 story free standing building (1st floor). Building for sale along with a second single story free standing building which is currently rented. The practice consists of 9 equipped operatories and 1 plumbed not equipped in a 2,945 sq ft office. Practice is open 5 days/wk. Seller works part-time and has 2 Associates. They see approximately 22-24 patients/day. There 4 days/wk of hygiene. PPO and Cash only. No advertising. Projecting approximately \$872K for 2015 with a Buyer's net of \$272K. Great potential for full time Buyer. Please contact your CPS Agent for more details. **Property ID #5085.**

Our services are free to buyers, so we encourage you contact us to have a specialist assigned specifically to you to answer your questions and guide you through the purchasing process.

100% FINANCING AVAILABLE TO QUALIFIED BUYERS

**Nationwide Toll Free Number: (855)672-3000 • Fax: (714) 333-4444**

# PRACTICE SALES, INC.

## and Appraising of Dental Practices



### PRACTICE FOR SALE - PALM DESERT



- Grossed \$1,139,675 in 2014. Projecting approximately \$1,068,510 for 2015.
- **Buyer's net of \$265,000**
- Well established general practice located in a free standing building with ample parking.
- Near shopping centers
- Off Highway 111
- Modern designed practice with 5 SPACIOUS equipped operatories with window view
- 2,350 sq ft office.
- Computerized with Genesis software.

- 100% patient referral.
- Seller works 4 days/wk with approximately 15-20 new patients/mo.
- 8 days/wk of hygiene.
- Insurance and cash only. NO HMO.
- Refers all specialty.
- Seller moving out of state.
- Great opportunity to own an established epractice.

Please contact your CPS Agent for more details.  
**Property ID #5058.**



Alice C. King, V.P.

# CALIFORNIA

## Specializing in the Selling

### LOS ANGELES COUNTY LISTINGS

**CANOGA PARK (GP) – Price Reduced – Low sales price!** This turn-key practice is located in a 3 story medical dental building with ample parking. Established approximately 10 years ago. Seller is currently working 1/2 day/wk with 1/2 day of hygiene. Sees approximately 10 new patients/mo. The practice consists of 2 equipped operatories, x-ray room with chair, small lab room, sterilization room, and private office in an approximately 1,000 sq ft suite. Have some HMO plans. 100% patient referral. Collecting approximately \$10K-\$15K/mo. Grossed approximately \$147K in 2014. There's approximately 500 active patient charts. Excellent opportunity for a first time buyer or a second office. Please contact your CPS Agent for more details. **Property ID #4357.**

**COVINA - Leasehold Improvements and Equipment Only!** Great starter practice located on a busy shopping center with plenty of parking spaces. Consists of 3 spacious equipped operatories, lab room, sterilization area, dark room, lounge room (plumbed) and a private office in a 1,680 sq ft office. The major equipment is approximately 9 years old. Has reasonable rent. On a major street with heavy traffic flow. Please contact your CPS Agent for information. **Property ID #5074.**

**DOWNEY - Practice has over 47 years of goodwill to offer.** One of the top 20 practices in Downey and got winner award for 2015. Known for its high quality dentistry, patient retention is strong here as generations of patients are seen here. While it has been established as a dental icon in the community for some time, it boasts a State-of-the-Art practice that has been completely remodeled in 2014. It consists of 3 equipped operatories in a 1,214 sq ft office with Easy Dental software and digital x-ray (1 sensor). Seller is currently working 3 days/wk and sees 15-18 new patients/mo. PPO/Cash/Some HMO. Has reasonable rent. Grossed \$398K in 2014 and it's Projecting \$416K for 2015 with a Buyer's net of \$154K. Excellent opportunity. Please contact your CPS Agent for more information. **Property ID #5080.**

**DUARTE (GP) – Turn-Key practice located in a busy shopping center.** Has great signage. Practice consists of 2 equipped operatories, 1 plumbed not equipped in a 996 sq ft office. Seller is currently working 3.5 days/wk and Associate 1 day/wk. Sees approximately 9-10 patients/day. Insurance/Cash/Denti-cal/Cap. It's computerized with DentiSoft software and digital x-ray (1 sensor). Grossed approximately \$139K for 2014 and projecting \$143K for 2015. Excellent opportunity. Low sales price! Please contact your CPS Agent for more details. **Property ID #5048.**

**GLENDALE (GP) - Corner location only minutes away from the Rose Bowl and the popular shopping mall, the Americana.** The great location with excellent visibility and signage will help continue the growing trend of this practice. The practice consists of 3 equipped operatories with 1 plumbed not equipped in consultation room. It's computerized with Practice Management software and Digital X-ray. Seller works 4 days/wk and Associate 2 days/wk. Sees approximately, 10-16 patients/day. Insurance and cash only. No HMO. Does minimal advertising. Projecting approximately \$522K for 2015. BUYER'S NET OF \$244K. Please contact your CPS Agent for more information. **Property ID #5045.**

**HUNTINGTON PARK (GP) – Well established general practice with approximately 30 years of goodwill located in a one story strip shopping center.** Practice consists of 3 equipped operatories in a approximately 860 sq ft office. Seller is currently working 5 days/wk and sees approximately 9-10 new patients/mo. Insurance/Cash/Denti-cal. Does minimal advertising. Grossed \$203,989 on 2014 and projecting \$222K for 2015. Buyer's net of \$112K. Great practice. Please contact your CPS Agent for more information. **Property ID #5054.**

**LOS ANGELES Price Reduced! – Leasehold Improvements & Equipment Only!** General practice located in a multi story professional building. This modern designed practice consists of 3 equipped operatories, sterilization, and private office in approximately 824 sq ft suite. The office is computerized with Easy 2000 software and the equipment is approximately new to 5 years old. There 1 digital sensor. Has a long term lease. It's a great potential for a full time and right buyer. Seller will be focusing on primary practice. Some charts included. Please contact your CPS Agent for more information. **Property ID #4467.**

**Nationwide Toll Free Number: (855)672-3000 • Fax: (714) 333-4444**

# PRACTICE SALES, INC.

## and Appraising of Dental Practices



Robert A. Palumbo, Executive V.P./Partner

**LOS ANGELES (GP/PERIO/IMPLANTS)** – Beautiful practice located in the very desirable Miracle Mile. The office offers an incredible built out consist of 5 equipped operatories with amazing views to the city. No digital x-ray, however, is completely prewired through discrete floor access for all computers and digital x-ray. Major equipment is 5 years and has Dentrix software. Seller is currently working 4 days/wk and sees approximately 14-16 new patients per month. Income source is approximately 20% insurance and approximately 80% cash. The practice was established approximately 18 years ago. Grossed approximately \$431,169 in 2014 and projecting \$437K for 2015. Buyer's net of \$146,926. Great office with a flat rate lease. Please contact your CPS Agent for more details. **Property ID #4489.**

**NORTH HOLLYWOOD / TOLUCA LAKE** - Established practice with 29 years of goodwill. This general practice is located in a corner 2 story medical / dental building with great street visibility and heavy traffic flow. Easy access to the freeway. Practice consists of 5 equipped operatories with Digital X-ray and Practice Works software on a 1,500 sq ft suite. Seller is currently working 4 days/wk with Associate 2.5 days/wk and 7 days/wk of hygiene. PPO and Cash only. Sees approximately 25-30 new patients/mo. Does minimal advertising. Projecting approximately \$1,266,960 for 2015. Net \$455K. Great practice. Please contact your CPS Agent for more. **Property ID #5081.**

**NORWALK - Price Reduced!!** With over 65 Years of Goodwill, this practice is well known in the local community. It is also a corner location, right off of the 5 freeway. Currently while only operating on 1 day a week, it is still driving good numbers. Practice consists of 3 equipped operatories and 1 plumbed not equipped. Note the private office is plumbed, and also has in place cabinetry with a stainless steel sink which could be used for a fourth operator. Projecting approximately \$271K for 2015. Please contact your CPS Agent for more details. **Property ID # 5026.**

**PASADENA** - Leasehold Improvements and Equipment Only! To our knowledge this is the only dental practice located in the beautiful Huntington Pavilion, which is located right next to the Huntington Memorial Hospital. It has a very modern sheik design that you can only truly appreciate by seeing it, and everything through the practice is in immaculate showroom condition. Seller built out the practice approximately 1.5 years ago. Includes an adjacent parking structure. Conveniently located between where the 210 and 110 Freeways. Practice consists of 3 spacious operatories, lab/sterilization combo room, consultation room and a private office in a 1,552 sq ft suite. Has a long term lease. It's great opportunity to establish your practice. Please contact your CPS Agent for more details. **Property ID #5065.**

**POMONA** – Leasehold Improvements & Equipment Only! This modern designed practice has been known a dental office for over 50 years. Located in a single story professional building with plenty of private parking. The practice consists of 4 equipped operatories, lab room, sterilization area, lounge room, private office and 3 storage rooms in an approximately 1,400 sq ft office. Just minutes away from the 10 freeway. Close proximity to a local hospital, Western University and the Pomona Fairgrounds. Landlord is easy to work with and offers a very rare gross lease (NO common area or triple net fees). Great opportunity for a starter office. Please contact your CPS Agent for more details. **Property ID #5057.**

**RESEDA** – Well established turn-key general practice with over 50 years of goodwill. This family practice is located in a single story free standing building with ample parking. It's on a major street of Reseda with lots of heavy traffic and excellent street visibility. The practice consists of 3 equipped operatories (stand up dentistry), sterilization/lab combo, dark room, and private office in a approximately 950 sq ft office. Not computerized. Has older equipment. Seller works 4 days/wk and sees approximately 8-20 patients/day. Income source is approximately 30% insurance, 30% cash, 10% Denti-cal and 30% capitation. Grossed approximately \$281K in 2014. Has monthly revenues of \$22K. Seller is retiring. Practice next to a residential community. Please contact your CPS Agent for more information. **Property ID#5017.**

**SANTA CLARITA (GP)** – This turn-key practice is located in single corner location with heavy traffic flow and excellent street visibility. Practice consists of 3 fully equipped spacious operatories and 5 plumbed not equipped in a 2,600 sq ft office. Plumbed for Nitrous and H2O. It's computerized with Easy Dental software and digital x-ray. Has new equipment. Seller works 2 days/wk with 2 days/ of hygiene and sees approximately 10 new patients/mo. Cash and PPO Only. No HMO. Reestablished the practice in September 2013. Has long term lease. Averaging \$19,000 per month on a part time schedule. Grossed approximately \$230K in 2014 and projecting approximately \$236K for 2015. Great opportunity for a 1st time buyer or second office. Please contact your CPS Agents for more information. **Property ID #5013.**



John W. Knipf, President

# CALIFORNIA

## Specializing in the Selling

**TORRANCE** – General practice located in a busy single story shopping center with lots of traffic. Practice consists of 3 equipped operatories, sterilization/lab combo, consultation room, lounge room, and private office in an approximately 1,046 sq ft suite. Computerized with digital x-ray. Seller works 4 days/wk and sees approximately 10-12 new patients/mo. No HMO. Projecting \$325K for 2015. BUYER'S NET OF \$103K. Great office. Please contact your CPS Agent for more details. **Property ID #4477.**

**WEST COVINA** - Leasehold Improvements and Equipment Only! This practice is located up against the Foothill Mountains less than 1/2 mile off the 10 Freeway for convenient access. The area around our newly built-out office is exploding with growth, and surrounded by too many anchor tenants to mention. Notable are the 450+ new townhomes that are being built right in front of our practice. The practice consists of 7 equipped operatories, 1 plumbed not equipped in a 2,450 sq ft office. It's computerized with Dentrix software and digital X-ray (1 sensor). The Seller is the landlord is willing to negotiate a good lease. Please contact your CPS Agent for more details. **Property #5077.**

### ORANGE COUNTY LISTINGS

**ANAHEIM (GP) - Price Reduced!!** The practice has over 24 years of goodwill to offer. With very convenient freeway access, it is currently located in a single story strip mall and right around the corner from Anaheim Memorial Medical Center. This practice consists of 3 equipped operatories in a 959 sq ft suite. It's computerized with Dentrix software. No digital. Retiring seller is currently working 4.5 days/wk and sees approximately 16-20 patients/day on a busy day. PPO/Cash/Denti-cal. Patient base is approximately 60% young adults. 100% Patient Referral. Grossed \$467K in 2014. Projecting approximately \$527K for 2015. Buyer's Net of \$245K Great opportunity. Please contact your CPS Agent for more details. **Property ID #5066.**

**IRVINE** – Established approximately 30 years ago, this practice is located in a 2 story professional / medical building. Practice consists of 4 equipped operatories. Two operatories are plumbed for nitrous and oxide. It's computerized with JDent/Light Year software and digital x-ray (2 sensors). Seller is currently working 4 days/wk (part time) with 2.5 days/wk of hygiene. Income source: Ins./Cash/Cap. Grossed approximately \$435K in 2014. BUYER'S NET OF \$128K. Please contact your CPS Agent for more details. **Property ID #5055.**

**LAGUNA HILLS - Price Reduced!!** – Modern designed General Practice with over 15 years of goodwill located in a 5 story medical / dental building. This practice consists of 2 equipped operatories, sterilization/lab combo room and private office (plumbed) in a 1,107 sq ft suite. It's computerized with EagleSoft software and digital x-ray. Seller is currently working 2-3 days/wk and sees approximately 20-25 new patients/mo. Ins/Cash/Cap (~\$500/mo). Grossed approximately \$319,024 in 2014. Buyer's net of \$101K. Seller will be focusing on family. Please contact your CPS Agent for more information. Great opportunity. **Property ID #5033.**

**ORANGE (GP)** – Well established practice with 42 years of goodwill. This practice consists of 8 equipped operatories in a 2,640 sq. ft. suite located in a two story free standing building on a busy street. The 2nd floor has a lab, lounge, & office. Attracting approximately 30+ new patients/mo. Intra Oral Camera, Digital X-ray, & Dentrix Software. PPO & Cash Practice. Projecting approx. \$827K in 2015 w/ a Buyer's Net of \$326K. Please contact your CPS Agents for mode details. **Property ID #5059.**

**ORANGE** - Leasehold Improvement and Equipment Only! This beautiful office is located in a single story free standing building just south of the Historic Orange Circle. It is walking distance to shops and restaurants and convenient access to the 22, 55 and 57 freeways. The practice consists of 4 spacious equipped operatories with digital x-ray in a 1,300 sq ft office. Seller is the landlord and will give a reasonable rent. Please contact your CPS Agent for more details. **Property ID #5082.**

**Nationwide Toll Free Number: (855)672-3000 • Fax: (714) 333-4444**

# PRACTICE SALES, INC.

## and Appraising of Dental Practices



Tony Frechette, V.P.

**NEWPORT BEACH** - This general practice established in 2002 and is located in a 2 story medical building near residential area. Building is being remodeled and will be completed in January 2016. Seller is currently working 4 days/wk, Associate when needed and with 3 days/wk of hygiene. Sees approximately 15 new patients/mo. PPO & Cash only. No HMO. Does minimal advertising. Practice consists of 6 fully equipped operatories and 1 plumbed not equipped in a 1,956 rentable sq ft suite. It's computerized with Easy Dental software and digital x-ray (1 sensor). Projecting approximately \$643,160 for 2015 with a Buyer's Net of \$168,685. Great practice. Please contact your CPS Agent for more details. **Property #5086.**

**RANCHO SANTA MARGARITA** - State-of-the-Art general practice located in a 2 story shopping plaza. Established in 2005. This beautiful office consists of 7 equipped operatories with digital x-ray and Dentrix software in a 2,250 sq ft suite. The seller is currently working 3.5 days/wk, Perio 1x/mo and with 4 days/wk of hygiene. Sees approximately 35-40 new patients/mo. PPO / Cash /Some HMO. Grossed \$781K in 2014 and Projecting \$811K for 2015 with monthly revenues of \$67K. NET OF \$270K. Great practice. Please contact your CPS Agent for details. **Property ID #5079.**

**SANTA ANA** - General practice located in a busy 2 story strip mall with ample parking. This practice consists of 4 days/wk and sees approximately 15-20 patients/day. PPO and cash only. No HMO or Denti-cal. Grossed \$437K in 2014. Projecting \$538K for 2015. NET OF \$208K. Please contact your CPS Agent for more details. **Property ID #5075.**

### RIVERSIDE & SAN BERNARDINO COUNTY LISTINGS

**APPLE VALLEY (GP) - Price Reduced!** Established in 1978 this, practice is located in one story building. It consists of 3 equipped operatories with EagleSoft software and digital x-ray in a 1,350 sq ft suite. Seller is currently working 4 days/wk and sees approximately 15-20 new patients/mo. There is 2 days/wk of hygiene. Insurance and cash only. Does minimal advertising. Remodeled the office in Feb 2014. Has monthly revenues of \$45K. BUYER'S NET OF \$188,174. Great practice. Please contact your CPS Agent more details. **Property ID #5044.**

**CHINO HILLS** - Leasehold Improvement & Equipment Only! This dream practice was built out when a rare opening in the Costco Center became available. Everything is completely new, and built out exquisitely. Over \$8,000 was invested in just the frameless glass frontage, giving maximum exposure to the restaurants and retail store next to, and surrounding our practice. There is more traffic in the parking lot, than many major intersections in the area. The practice consists of 3 equipped operatories, 2 plumbed not equipped, lab & sterilization area, lounge room, storage room, consultation room, dark room, and private office in a ~1,470 sq ft suite. Move on your dream practice now, or it will be somebody else's! Area is surrounded by residential homes. **Property ID #4501.**

**INDIAN WELLS** - Great opportunity. This modern designed practice consists of 4 equipped operatories, lab room, lounge room, Cat Scan + Pano x-ray room, 2 consultation rooms, sterilization area, dark room and 2 private offices plus lecture room in a 2,850 sq ft office. Computerized with Intra oral camera. Major equipment is 10+ years old. Seller will be focusing on his primary offices. Located on a one story building near shopping plazas and residential community. Grossed \$360K for 2014 on 1 day/wk schedule. Please contact your CPS Agent for more information. **Property ID #5041.**

**MURRIETA - Price Reduced!** Well established general practice located in a 2 story medical dental building. Practice consists of four equipped operatories in a 1,350 sq ft suite. It's computerized with Easy Dental software, digital x-ray and intra oral camera. Seller work 1.5 days/wk each, Ortho 1x/mo with 2 days/wk of hygiene. PPO and Cash Only. Averaging 30 new patients per month. Grossed \$588K in 2014 and projecting approx. \$509K for 2015. Buyer's net of \$156K. Please contact your CPS Agent for more information. **Property ID #5061.**

**PALM DESERT** - Well established general practice located in a free standing building. This modern designed practice consists of 5 equipped operatories in a 2,350 sq ft office. It's computerized with Genesis software. 100% patient referral. Seller is currently working 4 days/wk and sees approximately 15-20 new patients/mo. Has 8 days/wk of hygiene. Insurance and cash only. Grossed \$1,139,675 in 2014. Refers all specialty. Seller is moving out of state. Great opportunity. Buyer's Net \$265,000. Please contact your CPS Agent for more details. **Property ID #5058.**



Fred Vuittonet, V.P.

# CALIFORNIA

## Specializing in the Selling

**PALM SPRINGS** – General practice established in 2005 and located in a one story free standing building. Practice consists of 3 equipped operatories with Practice Web software and digital x-ray. Major equipment is approximately 2 years old. Suite is 1,200 sq ft. Seller is working 5 days/wk and sees approximately 8-10 patients/day. Income source is approximately 25% insurance, 65% cash and 10% Denti-cal. Does little advertising. Projecting to do \$417,739 for 2015. BUYER'S NET OF \$175K. Please contact your CPS Agent for more information. **Property ID #4487.**

**RIVERSIDE GP + 2 Buildings** – Established in 1996 this modern designed practice is located in a 2 story free standing building (1st floor). Building for sale along with a second single story free standing building which is currently rented. The practice consists of 9 equipped operatories and 1 plumbed not equipped in a 2,945 sq ft office. Practice is open 5 days/wk. Seller works part-time and has 2 Associates. They see approximately 22-24 patients/day. There 4 days/wk of hygiene. PPO and Cash only. No advertising. Projecting approximately \$872,374 for 2015 with a Buyer's net of \$272K. Great potential for full time Buyer. Please contact your CPS Agent for more details. **Property ID #5085.**

### SAN DIEGO & IMPERIAL COUNTY LISTINGS

**EL CENTRO (GP + BLDG)** – Well established family owned practice with over 60 years of goodwill. This practice is located in a single story building. Building is for sale. Practice consists of 5 equipped operatories, lab room, lounge room, storage, x-ray room, sterilization room, dark room, and 2 private offices in a 1,857 sq ft office. It's computerized with SoftDent software and digital x-ray. Seller is currently working approximately 4.5 days/wk and sees approximately 12-15 new patients/mo. Fee for service. Grossed \$305K for 2014 and Projecting \$332K for 2015. Buyer's net of \$83K. Great practice. Please contact your CPS Agent for more details. **Property ID #5023.**

**OCEANSIDE - Price Reduced!!** – General practice established in 1998 is located in a professional medical dental building. This practice consists of 5 spacious equipped operatories. It's computerized with Dentrix software and digital laser x-ray (1 sensor). Seller is working 2 day/wk with 1 day/wk of hygiene. Sees approximately 18 patients/day. PPO/CASH/HMO. Grossed \$374K in 2014 and Projecting approx. \$359K for 2015. Please contact your CPS Agent for more information. **Property ID #5069.**

**POWAY** - General practice with over 20 years of goodwill is located in a one story building. Currently the Seller is working 4 days/wk and sees approximately 5-10 new patients/mo. PPO and Cash Only. Practice consists of 2 equipped operatories and 1 plumbed not equipped in a 1,240 sq ft suite. Does minimal advertising. Projecting approximately \$185K for 2015. Seller will be retiring. Great opportunity for a starter practice or for an experienced dentist with a vision to expand. Please contact your CPS Agent for more details. **Property ID #5084.**

**SAN DIEGO** – Established in 1986 this general practice is located 3 story professional building with ample parking. Seller is currently working 3.5 days/wk with approximately 15 days of hygiene/wk. PPO and Cash only. No HMO. Practice consists of 7 equipped operatories in approximately 2,980 sq ft suite. Computerized with Practice Work software and digital x-ray. Grossed \$1,982,000 in 2014 and Projecting approx. \$1,863,000 for 2015. NET OF \$361K. Great practice. Please contact your CPS Agent for more details. **Property ID #5072.**

### KERN, SAN LUIS OBISPO & VENTURA COUNTY

**BAKERSFIELD - Price Reduced!!!** The practice offers over 18 years of goodwill, and is a standing landmark known for its dental services. Located in a medical hub center for the city, the practice is across the street from the area's hospital, and conveniently located next to a pharmacy. The building owner who is also a dentist, occupies the other half of the free standing building, and very easy to work with. With a great rent, easy to work with landlord, and room to even expand further. Practice consists of 6 equipped operatories, 1 plumbed not equipped in a 1,800 sq ft suite. Computerized with EagleSoft software and Digital X-ray. Insurance/Cash/Cap. Seller works 1 1/2 days/wk, 2 Associate 1 day/wk each. 100% patient referral. Grossed \$350,014 in 2014 and Projecting to do approx. \$367K in 2015. Buyer's net of \$95K. Great potential for full time buyer. For more information, please contact your CPS Agent. **Property ID#5060.**

**Nationwide Toll Free Number: (855)672-3000 • Fax: (714) 333-4444**



# PRACTICE SALES, INC.

## and Appraising of Dental Practices



Dan Parnell, V.P.

**SAN LUIS OBISPO COUNTY** – Beautiful well established practice located in a two story medical / dental building. Seller works approximately 4 days/wk, Endo 2x/mo and with 8 days/wk of hygiene. Sees approximately 60 patients/ mo. Insurance and cash only. The practice consists of 8 equipped operatories, lab room, lounge room, storage room, consultation room, large sterilization room, and a large private office in a 2,626 sq ft suite. It's computerized with EagleSoft software and digital x-ray. Has monthly revenues of \$95K. Buyer's net of \$370K. Excellent opportunity. Please contact your CPS Agents for more information. **Property ID #5037.**

**SIMI VALLEY (GP + Buildings for sale)** - Great opportunity to invest in a general practice and real estate. There are two single stories free standing buildings, which the second property also includes a tenant in a separate detached building which generates rental income. Established in 1964, the 1,900 sq ft. practice consists of 4 equipped operatories with 2 that are plumbed, but not equipped and digital x-rays. It's computerized with Dentrax / Gendex software. Seller is currently working 3 days/week with 2 hygiene days. No advertising. With local business development in process, the potential for growth in the area and within the practice are very high. Grossed approximately \$273,790 in 2014. Has a Buyer's Net of \$124K. Please contact your CPS Agent for more details. **Property ID #5027.**

**VENTURA (GP)** - This practice has 36 years of goodwill located in a 2 story professional building (1st floor w/ direct access). Modern designed practice with 4 fully equipped operatories in a 1,862 (+ free bonus room) sq ft suite. Every operatory has dual monitors and lights suspended from above making the operatories even more spacious than they already are. Each operatory has floor to ceiling windows providing a plenty of natural light with custom fit shades. Computerized with Dentrax software and digital x-ray. Equipment is approximately 2-15 years old. Seller is currently working 4 days/wk with 3 days/wk of hygiene. See approximately 14-16 patients/day. Insurance and cash only. Grossed approximately \$423K in 2014 with monthly revenues of \$35K. BUYER'S NET OF \$92K. Great practice. Please contact your CPS Agent for more information. **Property ID #5039.**

### SPECIALTY OFFICE LISTINGS

**CHINO (Ortho) – Leasehold Improvement and Equipment Only + Condo.** This is a rare opportunity to purchase a condo located in a single story strip mall. The condo has been modified unlike others there, with a patio and additional windows providing bright natural lighting. This practice consists of 4 chairs in open bay with 1 equipped operatory, 1 lab/lounge room, sterilization room and private office in a 1,170 sq ft condo. The facility has been always at this location for approximately 40 years. Please contact your CPS Agent for more details. **Property ID #5076.**

Keep Up To Date with Us on Facebook - <http://facebook.com/MYCPSTEAM>

View Select Videos on You Tube - <http://youtube/MYCPSTEAM>

### Need CE Credits?

View Upcoming Continuing Education Opportunities: <http://www.calpracticesales.com/blog>

#### SELLER'S:

DIRECT E-MAIL ADDRESS TO BROKERS/AGENTS

John W. Knipf: [jknipf@calpracticesales.com](mailto:jknipf@calpracticesales.com)

Robert A. Palumbo: [rpalumbo@calpracticesales.com](mailto:rpalumbo@calpracticesales.com)

#### BUYER'S:

DIRECT E-MAIL ADDRESS TO BROKERS/AGENTS

Alice King: [aking@calpracticesales.com](mailto:aking@calpracticesales.com)

Tony Frechette: [tfrechette@calpracticesales.com](mailto:tfrechette@calpracticesales.com)

Dan Parnell: [dparnell@calpracticesales.com](mailto:dparnell@calpracticesales.com)

Fred Vuittonet: [fvuittonet@calpracticesales.com](mailto:fvuittonet@calpracticesales.com)

John W. Knipf (Neff) President & Robert A. Palumbo, Executive V.P./Partner • Also serving you: Alice C. King, Tony Frechette, Dan Parnell & Fred Vuittonet

[www.calpracticesales.com](http://www.calpracticesales.com)

— DID YOU ACQUIRE A DELTA PREMIER DENTAL PRACTICE BETWEEN 2011 AND MAY 1, 2014?

— WERE YOU REQUIRED TO ALSO TAKE DELTA'S PPO PROGRAM IN ORDER TO MAINTAIN DELTA PREMIER?

— WOULD YOU LIKE TO TERMINATE YOUR PPO RELATIONSHIP AND MAINTAIN DELTA PREMIER?



WOOD AND DELGADO



**PATRICK J. WOOD  
& JASON P. WOOD**  
ATTORNEYS AT LAW

If so, we may have  
a solution for you.  
Please call our firm for a  
free consultation and see if you  
qualify to DROP THE PPO!

800-499-1474  
[www.DentalAttorneys.com](http://www.DentalAttorneys.com)

## THE AUTHORITY IN DENTAL LAW

### Specializing In

Practice Acquisitions/Sales • Partnerships  
Business Transactions • Lease Negotiations  
Estate Planning • Transitions  
Business Litigation

**S. ORANGE COUNTY** Pedodontic Practice. 4 Ops, 1 year new equipment, OpenDental, Digital, Pano. \$236K GR w/room to grow. HSPPT-Thinh Tran 949-533-8308-#CA222.

**newly built** high end office available for sub-lease/option to buy, 3-4 days/week, north glendale/montrose area, 8183700112.

**Pursuing ownership?** Live Oak Bank can finance your dental practice with customized loan terms and quick credit approvals. 877.890.5867 [www.liveoakbank.com/healthcare](http://www.liveoakbank.com/healthcare).

**Pediatric Dentist** Board Certified Wanted - El Monte, CA. Modern office, great staff. 626 444-2605, [atlasdentalinfo@gmail.com](mailto:atlasdentalinfo@gmail.com).

**Cecilia Chen, Esq.** can help you ensure that your practice and family are protected through proper estate planning. Call us for a complimentary consult. Toll Free: 855-850-4111, [Cecilia@practiceatty.com](mailto:Cecilia@practiceatty.com) or [www.practiceatty.com](http://www.practiceatty.com).

**Naples area** of Long Beach. Practice collects \$625,000/year on 4 days/week with 8 days of hygiene per week. Seller refers everything. 5 ops. Asking \$475,000. Kurt Skarin 805-777-7707.

**Dental office for sale** ExceptionalDDS.com Fully digital and paperless. 6 ops. Surgical recovery room. Whittier California. Only 120k! 949-510-0225.

**Dental chair** Royal Model 17. Great condition. Photos on request. Make reasonable offer. Paul. [paulkratzer@yahoo.com](mailto:paulkratzer@yahoo.com). 323-528-1442.

**Dental Assistant Needed** in Wilmington,CA Email resumes to [fshadaieedental@yahoo.com](mailto:fshadaieedental@yahoo.com) Thank You.

**IN HOUSE PERIODONTIST AVAILABLE. ALL SURGERIES AND IMPLANTS. BOARD CERTIFIED. IV SEDATION. HAS ALL INSTRUMENTS AND ASSISTANT. GENTLE AND CARING. 8185214947. DENTALPLUSPERIO@GMAIL.COM.**

**SHASTA COUNTY, CA** Grossing \$851K, Beautiful Office, Est 25 Yrs, 6 Ops - 100% Financing Available. Call ProMed 888-277-6633 [Ref#D238].

**Intraoral Cameras** on SALE! \$3149 for 4 cameras, \$2384 for 3, \$1664 for 2. Use PROMO code TRADER on [www.Lensiora.com](http://www.Lensiora.com).

**Northridge** fully equipped dental office in shopping center great location no patients. 818 709-8645.

**COASTAL OC** General Practice for Sale, Asking \$385K, for more details contact Brooke at 714-259-0501.

**Looking for a Dentist Position** willing to learn and help to grow your practice 786-651-8381 or [jujikal@comcast.net](mailto:jujikal@comcast.net).

**Well established** practice looking for an experience dentist to integrate into a long term position. One to two days, leading to more days over time. General practice with great patients and staff. email:[contact@indianwellsdental.com](mailto:contact@indianwellsdental.com).

**Mineralized Cortical bone** 250-1000um Lowest pricing anywhere great for extractions \$22.00 per .25cc [www.denatalprodx.com](http://www.denatalprodx.com).

**ASI self contained** for sale \$4,200 we prefer selling both unit. They are in working condition. call 209-322-3429.

**Have a commercial lease?** Is your office lease as thick as a novel? Need to know what's hidden inside that? Call Kerendian & Associates 888-299-7848.

**FACT** An ADA study demonstrated that 1 out of 3 dentists will be disabled long enough to collect benefits. Call us for a FREE Disability Insurance Appraisal 855-346-9729 [di4dds.com](http://di4dds.com).

**Dental Practice** in West Hills. Position Avail: HYGIENIST part-time (SAT. only at this time) DENTAL ASSISTANT part-time. Email Resume: [dentistrygm@gmail.com](mailto:dentistrygm@gmail.com).

**ORTHODONTIST** UCLA grad experienced specialist in general offices. Great communicator Spanish speaker faculty member. Can train staff. [drcsaper@gmail.com](mailto:drcsaper@gmail.com) 646-334-0100 [saperorthodontics.com](http://saperorthodontics.com).

**Associate needed** Full-Time in the Central Coast multiple locations available. Possible partnership for the right candidate. Base pay plus production, new graduates welcome. Send resume to [friendlymilesdentalgroup@yahoo.com](mailto:friendlymilesdentalgroup@yahoo.com) or fax to (805)928-6788.

**Free Dentists Stool** (\$325 Value) with the purchase of an Assistants Stool for \$450. 100's of Color Choice's. Made in USA Call (800) 423 - 5657 or visit [DHPDENTAL.COM](http://DHPDENTAL.COM) for more details.

**PRACTICE FOR SALE** LOS ANGELES LH w/ 3 eq ops 1 1 pmbd in 1,702 sqft ste. California Practice Sales, Inc. Phone: 714-639-2775.

**VICTORVILLE** General Dentistry, 6 Ops, 3 Equipped. SoftDent, 34 years of Goodwill. \$313K GR and \$147K Adj. Net. HSPPT-Kerri McCullough 949-566-3056-#CA149.

**Need your plans** completed correctly and ready for the city by a Certified Interior Designer? All County Construction. 714-240-7179.

**P.F.S. BUYING A DENTAL PRACTICE?** Call Sunwest Bank for all your lending needs - 714-730-4412.

**DENTAL OFFICE LEASEHOLDS SALE** SANTA CLARITA. Sale of equipment/leasehold improvements. 4 operatories. Street-visible retail location. Broker - Charles Kim 800-416-2055.

**Chinese-speaking** dental assistant-PT, near Brea/Rowland Heights. Email resume to [use8office@gmail.com](mailto:use8office@gmail.com).

**INLAND EMPIRE PRACTICE SALES** SERVING THE INLAND EMPIRE EXCLUSIVELY!! LOCAL, PERSONALIZED SERVICES FOR DENTAL PRACTICE SALES AND PURCHASES. CALL TOM @ (951) 816-6242. [iepracticesales.com](http://iepracticesales.com). A subsidiary of San Diego Practice Sales.

# HOW DO I KNOW WHEN TO SELL?

&

Who can I trust  
to help me  
NAVIGATE <sup>THE</sup> SALE?

(855) DDS - 4DDS (855) 337-4337

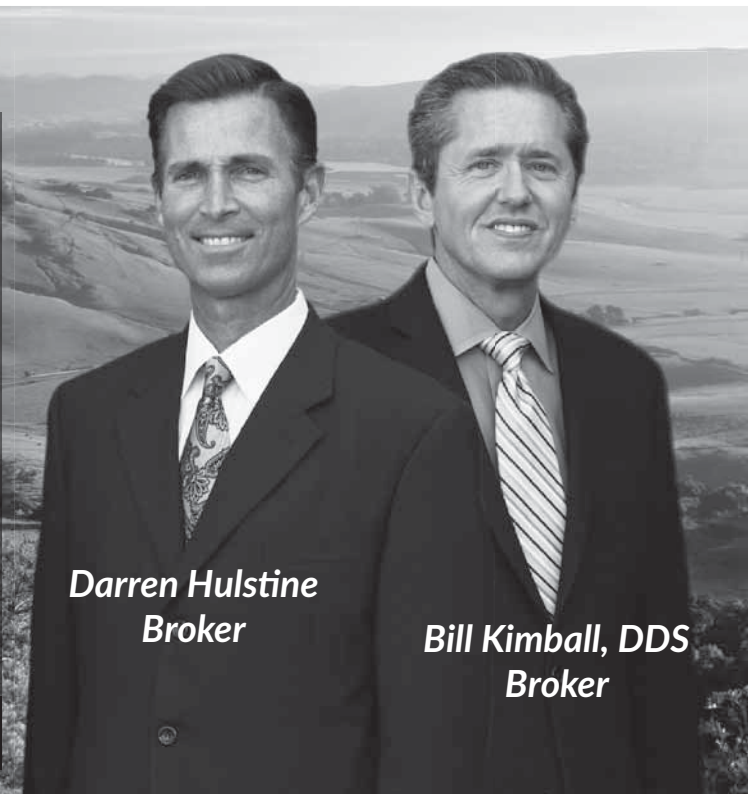

**Darren Hulstine**  
Broker

**Bill Kimball, DDS**  
Broker

## San Luis Obispo Practice

*Incredible opportunity to practice in the happiest city in America. Beautiful area to raise a family or retire. Laser periodontist seller does not place dental implants, so there's a huge potential for growth. Beautiful 1,100 square foot office with 4 equipped operatories. The seller is willing to retire or to partner with the right periodontist. Beautiful and well equipped office. Easy parking. Friendly team. Dr will entertain all offers and parties for either half or the whole practice. Half practice valued at \$320,00. Call today for a showing.*

## Glendale Practice

*Prestigious, high-tech general and cosmetic practice. Beautiful office with great exposure. Great space at 1,000 square feet and 4 equipped operatories. Experienced team. Located in busy Glendale near great shopping and entertainment (about a mile from Glendale Galleria). Collections have been consistent for several years. Close to freeway with easy parking. Real Estate available priced separately. Call today for a showing.*

## Santa Barbara Practice

*This well-established multi-generational practice has proven to be a winner. With 3 operatories and 600 sq. ft. you'll love the cottage feel. This is the perfect opportunity for a first time buyer and serves an elite patient base with features like digital charts and digital x-ray. A very friendly and motivated team make this 3-day-a-week practice a comfortable investment and it's ready to grow. This practice is positioned minutes from downtown and the beach. The practice is booked out in advance with almost no openings. Landlord is friendly and eager to work with the new dentist. Please call us for a showing.*

**SAN JOSE** - Pending

**SANTA MARIA** - High quality personal dentistry

New Listing! **SANTA MARIA** - Call for details

**ORCUTT** - Established 30 years, great visibility

**NORTH SANTA BARBARA COUNTY** - Call for details

New Listing! **SANTA BARBARA** - Call for details

**GLENDALE** - 5 ops with lots of upside potential

New Listing! **GLENDALE** - 5 ops, downtown just minutes from Galleria

**NORTH TUSTIN** - Call for details

**WESTLAKE VILLAGE** - Great location

**THOUSAND OAKS** - Turn key opportunity

**RIDGECREST** - Real estate also available

**VISTA** - 4 ops, nice practice

**LA HABRA** - Dr. retiring, opportunity to own

**RANCHO CUCAMONGA** - Pending

**SAN BERNADINO** - Pending

**ENCINITAS** - Call for details

[www.integritypracticesales.com](http://www.integritypracticesales.com)  
[kirsi@integritypracticesales.com](mailto:kirsi@integritypracticesales.com)

 **INTEGRITY**  
PRACTICE SALES

CA BROKER #01911548  
CA BROKER #01899816

# Experienced and Responsive Dental Attorney



**Cecilia Chen, Attorney**  
**Super Lawyer 2014**  
**Nominated by Peers**

*"I thought all attorneys were the same. But after seeing the frustration from the seller because of her lawyers, I knew that I have someone special on my side. Cecilia was thorough, efficient, and worked with my budget."*

Jack W. Chan, DDS

*"Cecilia represented me in the sale of my dental practice to my existing partner. She was very professional, thorough and easy to communicate with. The other attorney was contentious and uninformed about complex insurance issues and made no effort to preserve goodwill. Cecilia is very knowledgeable in dental practice law, particularly when it comes to partnership buyouts and practice acquisition. She went the extra mile to try and ensure that my interests were protected."*

Richard Lindsay, DMD

*"Her fees are very competitive and reasonable. In fact, her fees were entirely covered with a 3-months rent abatement that she had went out of her way to negotiate for me in a lease assignment."*

D. Aminov, DMD

## Serving Dental Professionals:

- Practice Sales and Acquisitions
- Lease Review and Negotiation
- Partnership Formation and Buy-Out
- Practice Start-Up and Incorporation
- Associate and Fee Sharing Agreements
- Estate Planning



LAW OFFICES OF  
**CECILIA CHEN**

**Toll Free: 855.850.4111**

**Email: [cecilia@practiceatty.com](mailto:cecilia@practiceatty.com)**

**[www.practiceatty.com](http://www.practiceatty.com)**

12.15

**TIRED OF PAYING HIGH RENT????** TIRED OF DEALING WITH DIFFICULT LANDLORDS???? IF SO, contact DDS Xpress Realty your connection for all Real Estate needs. Tina Ochoa, Realtor BRE # 01049085 (951) 309-3196.

**Buying A New Practice** Call Bob Affleck for your practice financing needs 949-939-4550.

**DENTAL OFFICE FOR SALE** San Diego City Heights area dental office, 2 operatories. Contact [universitydentaloffice@gmail.com](mailto:universitydentaloffice@gmail.com) for more info.

**Parttime GP** DR and RDA or DA and TX coordinator/Biller NEEDED in UPLAND fax Resume 909-949-3005.

**WEST HOLLYWOOD** General Dentistry. 4 Ops, Professional Building, Digital, \$623K GR in 2014. HSPPT-Kerri McCullough 949-566-3056-#CA212.

**Looking to purchase** new/lightly used LED Curing Light. Please text/call 323-819-6714 with brand, model, and price. Thank you.

**GP position** open MWF Comfortable working with children. OCS, Spanish a plus. partnership/ownership Biz/Building with Pedro Sugarbug888@gmail.com.

**Statim 2000** Sterilizer with an extra tray for sale, Asking \$2000 obo, call (818) 631-8180.

# AND THE AWARD GOES TO...



## AWARD WINNING END OF THE YEAR SPECIAL



Call (800) 397-6046

Sensors starting as low as

# \$3,999

FREE Installation and FREE Set Up  
Offer Expires December 31, 2015



Buy it! Sell it! Trade it!!!

**ANAHEIM PRACTICE** AND BUILDINGS FOR SALE – Dr retiring after 37 years in this location – 3 operatories – grosses over \$400,000 on 4 easy days/week with low overhead of 55% - 3 separate buildings on same lot – one is 700 sq ft, one is 900 sq ft and are both unoccupied and the 3rd building has two dental offices of 1070 sq ft each - Thomas & Fees Practice Sales (714) 544-4341.

**Associate Dentist Needed for N. Orange County/Santa Ana office. Top Pay w/bonus potential!! 3+ years Exp with Valid State of California license. Please contact Rocio@assuredentalcare.com.**

**DENTISTRY SUNRISE TO SUNSET** Huntington Beach – 4 exam rooms. Real estate available. ID#CA76586. Call Maria at Practice Concepts 877-778-2020 x. 108.

**DENTAL PRACTICES WANTED** in Temecula, Murrieta, Corona. 4 – 6 ops. Growth Potential, PPO/FFS. Sellers call Loc Pham, Broker at LCF Financial, Inc. BRE#01875780. (714)550-7494 or practice@lcfinc.com | LCFPracticeSales.com.

**Experienced GP** to perform Implants, Extractions, and RCTs in your SoCA practice. Brings Equipment, Instruments, Materials. Flexible Schedule. Call 618.917.5805.

**Need a Blast from the Past?** Find anything printed in an old edition instantly using the search engine on our Dental Trader Archives page at <http://thedentaltrader.com/archive.htm>.

**Pediatric office** looking for experienced back office assistants, PERFECT SPANISH a MUST. Great compensation, friendly environment. Email resume to natalie000@msn.com.

**PRACTICE FOR SALE** MIRA MESA. 20+ yr GP, 4 Ops. in 1300 sq.ft. PPO: SDPS: 760-599-7828.

**CENTRAL COAST/WINE COUNTRY** (3) op comput G.P. & 1,900 sq ft free stand. bldg. for sale. Bldg. houses dental office & a residential unit. Live in unit or rent it out! Fee for Service pts. 2015 Projected Gross Collect \$280K p.t. Growth potential. Seller refers all specialities & does little advertising. Seller retiring but will assist with Transition. D&M Practice Sales 818.591.1401.

**HYGIENE INSTRUMENTS FOR SALE** various cassetts, scalers, basic sets, syringes, sharpening stone, probes, slow speed. \$1,500 OBO Darabantp@yahoo.com.

**PRACTICE FOR SALE** NEWPORT BEACH GP w/ 22 yrs gdwll NET \$168K. California Practice Sales, Inc. Phone: 714-639-2775.

**Orthodontic assistant** or RDA needed with experience for Fast paced high volume office PT or FT Email: office@embrace-ortho.com.

**Glendale** Prestigious, high-tech general and cosmetic practice. Real estate available also. IntegrityPracticeSales.com, Broker Bill Kimball, DDS, BRE #01911548. (855) 337-4337.

**TORRANCE** dental office sale. Asking \$350k. Great area. 1k sqft, 2 ops equipped, 1 plumbed. All digital office. mk7dds@hotmail.com.

**In-Office Equipment Repair** 50% OFF FIRST HOUR Friendly. Prompt. Professional. Honest. Contact Us Today! 877-535-1733 / [www.repairmakers.com](http://www.repairmakers.com).

**CAVITRON SCALER TIPS** OLDER, BUT FUNCTIONAL 11 USED, 3 BRAND NEW IN BOX. \$1200 EMAIL OR CALL/TEXT DOCJTY@GMAIL.COM, 310-292-7812.

**Dentist wanted** in El Centro (imperial valley). \$800per day. US trained only. Full/part time position.(310)733-8508 Aakhorsand@gmail.com.

**Chula Vista/ Eastlake** Office Condo also for sale. Great location in professional medical building. 20 years of goodwill. Mainly PPO and Fee for Service, no HMO. Beautifully appointed office. Ken Rubin Practice Sales (619) 299-6161

**Anaheim private office** looking for an experienced dentist for Thursdays. Please email your CV to tdds75@yahoo.com for immediate consideration.

**Great Newport Beach Location Beautiful operatories for sub-lease for starters/new grads if you wish to start your own practice without capital.**  
**Behnamlaw@yahoo.com.**

**DENTIST WANTED!** in Cerritos. 3 DAYS FT. Great OFFICE and PAY. Must have DEA, license liability and US trained. jes.innovative@gmail.com.

**"Jason, I want to thank you** for your help and excellent advice thus far in my career. Purchasing this second practice has been a huge success this past year I appreciate all of your help!" WHITNEY GOMEZ, DDS Neverland, Texas. CALL TODAY 800-499-1474 WOOD & DELGADO [www.dentalattorneys.com](http://www.dentalattorneys.com).

**Northridge** Medical/Dental spaces for lease. Recently remodeled building at 9241 Reseda Blvd. 818 709-8645 or drgropp@aol.com.

**INLAND NORTH COUNTY, SAN DIEGO** Highly-regarded GP. FFS/PPO. 6 Ops. Beautiful, free-standing building with ample parking. Opportunity for property ownership. Russell Okihara-HSPPT 619-694-7077-#CA271.

**DA FOR QUALITY** SOUTH TORRANCE GP PRIVATE OFFICE PART-TIME. FAX RESUME, HANDWRITTEN COVER LETTER TO 310-326-5499. WILL TRAIN QUALIFIED INDIVIDUAL.

**Legal Tip** Does your attorney provide his cell phone number for emergencies? Attorney Robert W. Olson, Jr., 805.963.1120, [www.transdental.com](http://www.transdental.com).

**DANSEREAU CHAIR** FULLY FUNCTIONAL. YELLOW FRAME WITH VINYL/FABRIC UPHOLSTERY FOR PICKUP IN TORRANCE \$300. EMAIL DOCJTY@GMAIL.COM, 310-292-7812 CALL/TEXT.

**Thank you very much** for helping me through this and making the process so easy for me. – Safa Khaleel DDS, Mountain View, CA. [www.TheDoctorsInsuranceBroker.com](http://www.TheDoctorsInsuranceBroker.com), jonathan@tdibroker.com or call 800-767-0864.



CPA DDS  
**Wiederman & Potter**  
 PREMIUM PRACTICE SALES

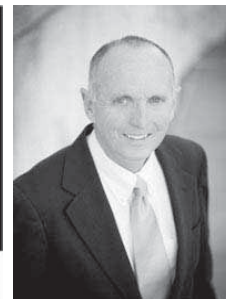

Art Wiederman, CPA, CFP  
 Broker #01511095

1415 Warner Ave., Suite C ~ Tustin, CA 92780  
 714.259.0501 ~ 714.259.0406 f info@wppps.com ~ wppps.com

Phil Potter, DDS, FAGD  
 Broker #01780656

## YOUR BRIDGE TO A SUCCESSFUL TRANSITION

# Premium Practice Listings

### ★ North Central Los Angeles #1100 ★

Restorative cash fee-for-service practice, contemporary suite/ all digital, 2015  
 Projected revenues over \$770,000  
**Asking \$575,000**

### Los Angeles Area PERIO #1090

Outstanding periodontal practice in a  
 premier location, five (5) treatment  
 rooms, 1,500 sq ft, seller retiring,  
 projected gross for 2015 over \$1 million.  
**Asking \$595,000**

### South Orange County #1099

Restorative fee-for-service practice, five  
 (5) equipped treatment rooms,  
 contemporary 2,000 sq ft., digital x-ray,  
 lasers, intraoral cameras, 37 years of  
 goodwill, seller will work-back,  
 2014 Gross revenues \$1,426,236  
**Asking \$1,300,000**

### Placer County #1073

Fee-for-Service  
 Restorative Practice  
 Beautiful Contemporary Office in  
 Great Location  
 All Digital with Cone Beam  
 2014 Gross Revenues \$1,629,000

**Asking Price: \$1,198,000**

### PERIODONTAL Practice #1092

San Francisco Bay Area, all digital,  
 annual profit over 55%,  
 2014 Gross over \$1,600,000

**Asking \$700,000**

### Sonoma County #1101

General Dental Practice and Building  
 2415 Square Foot Digital Suite  
 Eight Days/Week Hygiene  
 Projected 2015 Gross \$1,603,000

**Practice asking Price \$1,150,000**

### North Los Angeles County #1097

General esthetic and restorative practice,  
 turn-key, 10 treatment rooms, all digital,  
 seller retiring. 2014 revenues \$1,708,000

**Asking \$1,275,000**

### Fresno County #1091

Outstanding general dental practice and  
 dental building for sale, approx. 2,400 sq ft.,  
 six (6) treatment rooms, practice fully  
 equipped with digital x-ray equipment, seller  
 retiring, practice gross in 2014 \$535,000.

**Asking \$347,500 for Practice  
 Asking \$695,000 for Building**

### San Diego County #1093

Fee-for-Service restorative practice, shopping  
 center location, five (5) treatment rooms,  
 seller retiring, digital x-ray, laser, and intraoral  
 cameras. 2014 revenues \$531,260

**Asking \$385,000**

### Coastal Orange County #1079

Beach Location, 1,100 sq. ft., over 40 years  
 goodwill, seller owned building great lease,  
 2014 revenues 524,000

**Asking \$385,000**

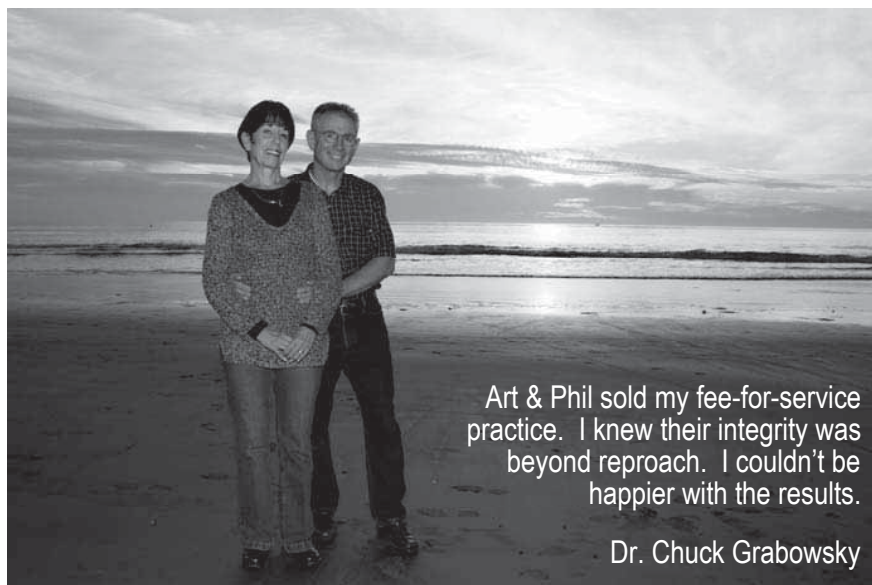

Art & Phil sold my fee-for-service  
 practice. I knew their integrity was  
 beyond reproach. I couldn't be  
 happier with the results.

Dr. Chuck Grabowsky



**Life Time Warranty!!!** Perfectionist, Fast, Caring & Patient-Friendly: Keep All Complicated Endo Your office Sends Out, visit: [www.socalrootcanal.com](http://www.socalrootcanal.com).

**ORAL SURGEON SPECIALIST** South Bay dental office looking for Oral/Maxillofacial Surgeon. Please email resume to [ufdhire@yahoo.com](mailto:ufdhire@yahoo.com).

**ONC Certified** Electronic Health Records(EHR) In Your Practice Management Software. Achieve a higher level of care for your patients with EHR. If you have 30% or more Medicaid visits you could also receive up to \$63,750 in government incentive payments. Call 1(800)397-6046.

**ORTHO** chula vista turnkey office condo for sale or lease. 4 chair open bay. For details/photos call 619 298-1775.

**We have 3 peri-apical** dental x-ray for sale we no longer use please call 209-322-3429.

**Sterilization pouches** 3.5 x 5.25 case of 2000 \$72.98 or 3.5 x 9 for \$74.77, [www.dentalprodx.com](http://www.dentalprodx.com).

**DENTAL PRACTICE FOR SALE TORRANCE:** Busy Shopping Center. Proximity to Freeway. Low Selling Price. Call Broker - Practice Sales & Appraisals (818) 999-9595.

**Space for Sublease** BH/LA area.Existing Perio office to share space. New office and equipment, fully staffed. 310-487-2101, [drr@perioartist.com](mailto:drr@perioartist.com).

**Endodontists available** at your office. We'll bring our equipment, supplies, microscopic, assistant. NO INVESTMENT needed on your part.[smartendo1@gmail.com](mailto:smartendo1@gmail.com).

**Handler Chuck/Changer** w /Lathe Model 16BN. Never used. \$550. OBO 949-202-4420.

**Looking for part time** General Dentist to work in beautiful PPO office in downtown Orange. No Endo skill necessary. [Loriabagai@sbcglobal.net](mailto:Loriabagai@sbcglobal.net).

**Is your ad missing?** Check the automated confirmation you received via email when submitting your ad, see if you exceeded 20 words w/o paying, forgot to include your phone number or email address. Did you miss the deadline? It's always the 7th of the preceding month.

**Front office** receptionist/Treatment Coordinator positions in Beverly Hills available. Experience a must. Submit resume to: [lkramer66@gmail.com](mailto:lkramer66@gmail.com). Must know Dentrax.

**Periodontist in your San Diego/Orange County office:** immediate implants, IV sedation, perio surgery, bone grafts, third molars, crown lengthening, root coverage, All-on-4/6, full mouth rehabilitation, etc. Will bring all supplies and instruments. Very personable, great with patients. 619-804-8339 or [socalperiodontist@gmail.com](mailto:socalperiodontist@gmail.com).

**THINKING OF SELLING** YOUR DENTAL PRACTICE???? Contact DDS Xpress Realty and find out why DDS Xpress Realty may be a better choice. Tina Ochoa, Broker BRE# 1049085 (951) 309-3196.

**ENDO** instruments New and like new many files, hand condensers/spreaders Will sell all very cheaply. (323) 851-6622.

**need experienced/friendly** office manager for busy office in coachella. email [sunshinedentalgroup06@gmail.com](mailto:sunshinedentalgroup06@gmail.com).

**PRACTICE FOR SALE WEST LA, GP W 3 EQ OPS 17 YEARS GDWL; SALE BY OWNER/RETIRING; GOOD LOCATION, CALL (310)636-9292.**

**Cecilia Chen, Esq.** has a strong background in real estate and practice purchase and sales. Let us assist you in your next practice transition. Call us for a complimentary consult. Toll Free: 855-850-4111, [Cecilia@practiceatty.com](mailto:Cecilia@practiceatty.com) or [www.practiceatty.com](http://www.practiceatty.com).

**ABO Board certified** Orthodontist w/ 2+ yrs. experience looking for part-time work in established Orthodontic clinic. Contact [OrthoProspect@gmail.com](mailto:OrthoProspect@gmail.com).

**PRACTICE FOR SALE RIVERSIDE** GP + 2 Bldg for sale. 9 eq ops. NET \$267K. California Practice Sales, Inc. Phone: 714-639-2775.

**Dental Instruments** New or like new condensers/carvers for composites and amalgams. Explorers, perio probes, 5 only-perio scalers (323) 851-6622.

**Looking for dental assistant** in Santa Ana part-full time. please email [granddentalgroup@gmail.com](mailto:granddentalgroup@gmail.com).

**Carson starter practice** collects \$126,000/year on 2 ½ days per week. Retail location. 3 ops. Seller is leaving the state. Asking \$100,000. Kurt Skarin 805-777-7707.

**EpiPen Epinephrine** Auto-Injector Adult 0.3mg. Expiration: July, 2016. MSRP \$550 for 2 pack. FOR SALE \$175 FOR ONE. [gaw1177@gmail.com](mailto:gaw1177@gmail.com).

**INLAND EMPIRE** General Practice, 7 Ops. Dentrax, Digital. 30+years goodwill. HSPPT-Kerri McCullough 949-566-3056-#CA283.

**WANTED** Current address of Kurt Conrad dba: Conrad Capital Kurt Conrad-Director of Professional Lending aka: Rep OZARKS CAPITAL FUNDING Last known address: 45751 Rancho Palmaras, Indian Wells, CA 92210 [www.ocflink.com](http://www.ocflink.com) email: [kurt.conrad@ocflink.com](mailto:kurt.conrad@ocflink.com) Ph: 949-300-2433 Fax: 949-759-0746. Please contact Bruce at The Dental Trader if you know the current whereabouts of this former advertiser. Thank you. 877 888 4237.

**Envision your dream practice** Now let us make it a reality. Contact Live Oak Bank for your practice financing needs. 877.890.5867 [www.liveoakbank.com/healthcare](http://www.liveoakbank.com/healthcare).

**Buying a practice?** Call today for a free consultation regarding the process and legal issues involved with your practice transition. (888) 776-5384. [www.dental-attorney.com](http://www.dental-attorney.com).

**DENTAL OFFICE** LEASEHOLDS SALE - ORANGE, CA. Retail center location, near freeway access. 5 operatories, 4 equipped. Like new condition, Built in 2015. Broker - Charles Kim 800-416-2055.

## INLAND EMPIRE PRACTICE SALES

**SERVING THE INLAND EMPIRE AND COACHELLA VALLEY EXCLUSIVELY!!  
LOCAL, PERSONALIZED SERVICE, FOCUSED ON YOUR TRANSACTION!**



**COLTON** - Fantastic 3 Operator, 1200 sq. ft. office!! Established 10 years, with large operatories (approx. 10' x 10'), digital x-ray each room. Gross \$\$ up 39% this year! Efficient, yet spacious layout. Sink and cabinetry each side of Op. Transitioning to paperless. Excellent condition. Great location on major thoroughfare near freeway. Solid patient base, well priced with great growth potential!

**SAN BERNARDINO** - Doctor retiring from her attractive General Practice with 20 years of goodwill!. It is located near the University, on a major road in a largely residential area. The office has 4 operatories (3 equipped) in 1330 sq. ft. Seller refers out Lots of dentistry. No HMO, capitation plans, or Denti-Cal. Great price!



**COLTON** - Doctor selling his satellite office to consolidate to his main office. Leasehold improvements and equipment, no patients included with purchase. Excellent location located near freeway exit. Good street side exposure. The office has 4 operatories with 3 equipped, with panoramic x-ray in 1900 sq. ft. Equipment in great condition. Very affordable price!

### WHY CHOOSE US?

\* Local \* Personalized Service \*

***I personally** meet with you at all stages of transaction. (Listing, Marketing, Negotiation, Consultants, Escrow)*

***I personally** show your office.*

***I personally** assist the Buyer to facilitate an efficient and smooth transaction.*

### WE HAVE BUYERS FOR YOUR PRACTICE !!

IN: RANCH CUCAMONGA, ONTARIO, CORONA, EASTVALE, RIVERSIDE, N. SAN BERNARDINO

**SEE OUR WEB SITE!!**



Thomas Fleming

Lic.#01168222

### RECENT SALES

Fontana - 5 op., 2300 sq. ft.

Fallbrook - 3 ops., 900 sq. ft.

## Inland Empire Practice Sales

c. 951.852.2560 • f. 951.244.6182 • [iepracticesales.com](http://iepracticesales.com)

Inland Empire Practice Sales: a subsidiary of San Diego Practice Sales

Buy it! Sell it! Trade it!!!

**Intraoral Cameras** INVENTORY LIQUIDATION! \$3149 for 4 cameras, \$2384 for 3, \$1664 for 2. Use PROMO code TRADER on www.Lensiora.com.

**Endodontists available at your office. We will bring our equipment, supplies, microscope, assistant. NO INVESTMENT needed on your part. smartendo1@gmail.com.**

**Professionalism** respectful and diligent to my project. All County did an exceptional job. Dr. M. Yung. 714-356-1203.

**P.F.S. DON'T OVERPAY** FOR THAT PRACTICE! Call Sunwest Bank FIRST- 714-730-4412. Sunwest Bank...Where Sensibility And Flexibility Meet.

**ASSOC DDS WANTED** ANAHEIM/LA office. (Min 3 years experience required) Great pay/bonus. Please Email resume socalteeth@gmail.com.

**SAN FERNANDO VALLEY** (8) Op fully eqt'd comput G.P. w central nitrous for sale. Located in a multi story high rise prof. bldg. on a main thoroughfare. Cash/Ins/PPO/HMO pt base with approx. \$7K+/mos Cap Ck. Dentrax, Digital X-Rays, & Digital CT Scan. 2014 Gross Collect \$1.33M+. 2015 Projected Collect \$1.4M. Open (5) days/week w no nights & no weekends. Averaging 50+ new pts/mos. (5) Hygiene days/wk & (7) DDS days/wk. Refers out Ortho, some Endo and some Perio surgery. D&M Practice Sales 818.591.1401.

**implantasmile.com** is looking for an associate dentist with over 3 years' experience with the desire to join our start of the art organization in either Glendora, CA or Huntington Beach, CA. implantasmile.com focuses on all aspects of general, cosmetic, restorative, prosthetics, and reconstructive & surgical dentistry. E-mail your CV to dr@implantasmile.com.

**GP needed** for Pediatric dentistry in Norwalk. Well trained, experienced staff in fun office setting. Send resumes to dtresume@cdgdental.com.

**Approximately 1000 Sq. Ft.** space by Subway, Starbucks & CVS in Paramount at Lakewood & Alondra intersection for private dental office. 323-653-8563.

**Trabucco Canyon** Ortho / Pedo Practice For Sale Greg Beamer, 909-542-4891.

**Spanish speaking dentist** wanted part time. With possible interest in buying practice in the future. Please email me at ktisbs@yahoo.com.

**Purchasing your first practice?** Bob Affleck at Citi Practice Finance he will guide you through the process 949-939-4550.

**DDS/DMD NEEDED** FOR WEDNESDAYS IN HUNTINGTON PARK. GREAT FAMILY OFFICE. SECURE ENCLOSED PARKING. PLEASE CALL (323)585-1000.

**DENTAL PRACTICES WANTED** in San Luis Obispo, Santa Maria, Santa Barbara County Production 300K+. Retiring Seller is ideal. Sellers call Loc Pham, Broker at LCF Financial, Inc. BRE#01875780. (714)550-7494 or practice@lcfinc.com | LCFPracticeSales.com.

**Orthodontist** looking to partner with a Pediatric office or partner with Pedodontist to start one. Contact: ortho\_wiz@yahoo.com.

**We thrive because of you!** Referrals from dentists and their staff directing new advertisers to The Dental Trader is our #1 source of new business. Thank you very much for making the introduction for us! We at The Dental Trader greatly appreciate it!

**COASTAL OC** General Practice for Sale, Asking \$385K, for more details contact Brooke at 714-259-0501.

**Specialist needed** for new office in Irvine spectrum. Please fax 9495527900.

**OCEANSIDE** Just Listed! Equipment and Leasehold Improvements. 3 ADEC Ops, Intraoral Cams, Panoramic, Digital and more. VERY Low Price. SDPS: 760-599-7828.

**AirTechniques** AT 2000 XR. \$1000 OBO. Last used 10/14. Manual/cleaning films incl. Year Unknown. Will Email Pix. 661-823-7644.

**YOUR NEEDS COME FIRST!** At Orange County Business Bank being local allows us to provide you with faster service. We can get things done! Contact Howard Boles 949-379-5704 Equal Housing Lender-The bank makes such loans without regard to race, color, religion, national origin, sex, marital status, age, handicap, familial status, applicant's receipt of income from any public assistance and applicant's exercise, in good faith, or any right under the Consumer Credit Protection Act. Member FDIC.

**COLLECTIBLE** 1950s Ritter dental unit and chair for display or collector. Very good condition. Asking \$500. Any offer considered. cdentaljohn@aol.com.

**TOUCH N HEAT UNITS** New & Refurb ORIGINAL U.S. Made 4NuBuchanan Tips Included 3Years Warranty \$855 For more Info: eismaildds@yahoo.com.

**Is it time to consolidate** your loans? Let's talk about how we can work together to simplify your finances. Call Wells Fargo Practice Finance at 1-888-937-2321.

**LA office for sale** Approx 2k sqft, 3 operatories, fully digital. Gross prod 400k, low overhead. Asking \$350k. joyeuna72@hotmail.com.

**Nobody wants to sue...or defend** against a lawsuit, but they are a fact of life. Deal with enough people, you are bound to end up in court. On that day, Kerendian & Associates is the firm you want representing you. 888-299-7848.

**Close office** end Sept, everything must go 2 full op, office supply etc must see. Contact email or 5623283626.

**PRACTICE FOR SALE** SANTA ANA GP in busy strip mall; NET \$208K. California Practice Sales, Inc. Phone: 714-639-2775.

**NEED PEDIATRIC DENTIST** BAKERSFIELD P/T, SEND CV AT luismiguelcollazos@yahoo.com, 6613272155 6613274122, fax 6613272528.

We are looking for established doctors interested in selling their practices & remaining long term associates. **Our acquisition is designed to defer taxes in the sale until your retirement & allow you to continue making a substantial yearly income.**



Does your practice collect more than \$300k annually?



Are you tired of managing staff, insurance billing & other business related issues?



Would you like to “cash out” of your practice & still work there?



Would you like to shield the purchase price from paying taxes now?

For more information, please contact us via email at [Info@streamlineden.com](mailto:Info@streamlineden.com)

**FRESNO** Priced to sell. Great retail location with easy parking and 6 ops. Ready for a busy dentist. IntegrityPracticeSales.com, Broker Bill Kimball, DDS, BRE #01911548. (855) 337-4337.

**Multi-specialty** dental office in Orange County available to share space with other dental specialists. Call (949)363-3914 or email: lesasaunders@gmail.com.

**SPANISH VILLAGE BY THE SEA** San Clemente – 4 exam rooms. Leaseholds & equipment. ID#CA76594. Call Maria at Practice Concepts 877-778-2020 x. 108.

**Endodontist needed** twice a month in Rancho Cucamonga / Ontario area. Please send resume or CV to shashimi100@hotmail.com.

**INLAND EMPIRE** General Practice. 4 Ops, Digital, Pano, located in a professional center. 2014 GR \$534K. HSPPT-Thinh Tran 949-533-8308-#CA285.

**Looking for a part-time dentist** in West Covina. Please email resume to: RubinNicholsDDS@gmail.com or fax to (626) 333-4666.

**Endodontic Practice** North County Inland. Very nice State-of-the-Art practice. Phenomenal growth potential. 3 Ops. Must see to appreciate. Oppty to buy building also. Bargain Price for quick sale. Ken Rubin Practice Sales (619) 299-6161.

**NEW** Aseptic portable dental unit Self contained Irrigation and Evacuation System ADU-17X & Portable asepticlight 110V ALU-29 Call (909)217-0814.

**Brand new Hereaus** Dynamix 6650124(henry schein price 2423.79 before tax) asking 1900.00 call Dr. Tim 5623353665.

**Modern & mobile websites perfected for Dentists. TheDocSites.com \$0 Set Up For Dental Trader Readers! Risk Free! Limited Time Offer. 818-616-3919.**

**Duarte general practice** collects \$390,000/year on 2 ½ days per week with \$190,000/year net income. 3 equipped ops plus one. Retiring. Asking \$275,000. Kurt Skarin 805-777-7707.

**Chemicleave 5000** AT 2000 film processor, safe light, Foster model trimmer, workstation carts, all in good working condition. (909)910-1688.

**Turnkey Torrance & San Pedro** offices for sub-lease. 4 ops, digital, very clean. Avail 1-5 days/wk. (310)502-4619 John.

**“Pat, Thank you** for speaking at the Western Conference last week. I attended your Thursday afternoon CE Class “Deal f the Year: \$6K of Advice for the Price of Admission”. With my lease up this year, and purchasing a new building, I was all ears, and your advise was worth way more than the promised amount of \$6,000.” SETH TAMBRINI, DDS. CALL TODAY 800-499-1474 WOOD & DELGADO www.dentalat-torneys.com.

**Selling I-CAT FLX** Purchased new May, 2014 list price \$154,999 remaining warranty transferable. \$100,000 OBO Call (707)4670875.

**MISSION VIEJO** ORTHO PRACTICE FOR SALE – 3+ operatories in 1200 square feet in professional building for over 20 years –grosses over \$13,000/month on 2 short days/week – contracts receivable over \$65,000 - Thomas & Fees Practice Sales (714) 544-4341.

**Need an RDA for upbeat orthodontic office. Hard working, team player, willingness to learn. Orthodontic experience ideal. Competitive pay. Call Judy at 310-785-0770.**

**Legal Tip: Buyers** It takes 15 years to fully deduct allocations to goodwill. Attorney Robert W. Olson, Jr., 805.963.1120, www.transdental.com.

**Private dental space** by Subway, Starbucks, CVS near superior Grocers, Stater Brothers at Bellflower/Paramount border in Paramount 310-849-6978.

**Complete Dental Office** Fully Equipped with Made in USA Dental Equipment for \$99 PM/OAC\* Terms and Conditions apply. Call (800) 423 - 5657 or visit DHPDENTAL.COM for more details.

**EXPERIENCED** PATIENT, PRESENTABLE In-House Endodontic Specialist searching for offices wanting to double production USING PROVEN METHODS TO RETAIN PATIENTS. 1EndInYourOffice1@gmail.com.

**If delivering a better** dental experience for your patients is your goal, upgrading or expanding your practice is one of the best investments you can make. Call Wells Fargo Practice Finance at 1-888-937-2321 or visit us at wellsfargo.com/dentaltrader.

**BOARD CERTIFIED** ENDODONTIST AVAILABLE to associate in an established endodontic or multi-specialty practice. Contact angler75@hotmail.com.

**Staff exam gowns** for \$26.17 per case of 50 polypropylene elastic wrist yellow or blue. www.dentalprodx.com.

**Cavitron slimline** focused spray ultrasonic insert. New, in box. 30K FSI-SLI-10S. Straight, green grip. 310-922-5666, Santa Monica \$110.

**NEED EXPERIENCED** DENTIST ONE DAY WEEKLY WE ARE IN ONTARIO CA CALL 909-983-8322 OR 909-241-1692 ASK FOR EVELYNA ENRIQUEZ.

**STERILIZER REPAIR** 15% OFF FREE Estimates. Fast Turnaround. Loaners Available. Contact Us Today! 877-535-1733 / www.repairmakers.com.

**ORTHODONTIST IN YOUR DENTAL OFFICE** Experienced orthodontist with supplies+qualified staff. Bilingual English/Spanish To OC/LA/RS County. orthosmile.oc.la@gmail.com.

**PRACTICE FOR SALE** EL CENTRO GP + BDLG w/ 60 yrs gdwill NET of \$87K. California Practice Sales, Inc. Phone: 714-639-2775.

**Dental Leasehold** for sale in Rosemead- 2nd fl, 2750sf, ~\$3900. major st close to FWY10. kkang98@hotmail.com for photo/info.

# HENRY SCHEIN®

## PROFESSIONAL PRACTICE TRANSITIONS

Contact  
one of our  
experienced  
Transition  
Consultants



Dr. Lee Maddox  
Lic. #01801165  
(949) 675-5578  
25 Years in Business



Dr. Thomas Wagner  
Lic. #01418359  
(916) 812-3255  
40 Years in Business



Dr. Dennis Hoover  
Lic. #123804  
(209) 605-9039  
36 Years in Business



Dr. Russell Okihara  
License #01886221  
(619) 694-7077  
33 years in business



Jim Engel  
License #01898522  
(925) 330-2207  
42 Years in Business

PRACTICE SALES • PARTNERSHIPS • MERGERS • VALUATIONS/APPRAISALS • ASSOCIATESHIPS • CONTINUING EDUCATION

### SOUTHERN CALIFORNIA

**ANAHEIM HILLS** – General Dentistry Practice with 4 Operatories has been established for 34 years. The practice utilizes Dentrrix and has 6 days of hygiene per week with long-term staff. #CA279 - In Escrow. Kerri McCullough - 949-300-0312.

**BAKERSFIELD** – *NEW LISTING* - General Dentistry practice with 4 operatories features Dentrrix, Dexis digital x-rays, and a Pano. This is a PPO/FFS practice. #CA299-Think Tran – 949-533-8308.

**BALDWIN PARK** – This General Dentistry practice features 5 Operatories, 4 Equipped in a 1,500 sq. ft. bright and airy suite. The Gross Receipts were \$276K in 2014 and the office has been established for 10+ years. The Seller is relocating out of state. #CA176- Kerri McCullough - 949-300-0312.

**BANNING** – This General Dentistry practice features 6 Operatories in a 1,873 sq. ft. suite. The practice utilizes Digital x-rays, EagleSoft, and is fully paperless. There are 8 days of hygiene per week. 2014 Gross Receipts of over \$1.4MM and adjusted net of \$382K. #CA183- In Escrow. Steve Caudill - 951-314-5542.

**BEVERLY HILLS** – This General dentist has been in practice for 20 years and downsized 2 years ago to a nice boutique office with valet parking for patients. 2 Operatories, 1 equipped. Practice utilizes OpenDental, Digital x-rays, and is paperless. 2014 Gross Receipts \$120K on 3 days/week. FFS and PPO only. Great for downsizing dentist or starting dentist. Huge opportunity for growth. #CA215- Mario Molina - 323-974-4592.

**BEVERLY HILLS** – General Dentistry Practice with 5 Operatories in a 1,500 sq. ft. suite, located in a prestigious building. Practice utilizes EagleSoft, Digital, CEREC, and most equipment is approximately 7 years old. 4 days hygiene per week, with dedicated, long-term staff. 2014 Gross Receipts were \$1.09MM+. #CA210- In Escrow. Kerri McCullough - 949-300-0312.

**CARSON** – This General Dentistry Practice with 3 Operatories is paperless and features EagleSoft, Digital X-rays, and Pano. All equipment is less than 3 years old. 2014 Gross Receipts of \$143K, room to grow. #CA280- Kerri McCullough - 949-300-0312.

**CYPRESS** – This General Dentistry practice has been established for 35 years in a 1,676 sq. ft. suite with 5 Operatories. Practice utilizes ComputerAge software and most specialty services are referred out. 7 days of hygiene per week. 2014 Gross Receipts were \$948K with \$426K Adjusted Net Income. #CA257- In Escrow. Kerri McCullough - 949-300-0312.

**GREATER LOS ANGELES AREA** - Periodontal Practice-This 5 Operatory Perio practice features Dentrrix software with Digital X-Rays, Laser, and an Intra-Oral Camera. There is a great referral base, long-time staff and 34 years of Goodwill. #CA173- Kerri McCullough - 949-300-0312.

**HACIENDA HEIGHTS** – *NEW LISTING* – General Dentistry Practice with 5 operatories, 3 equipped, 2 plumbed, not equipped. Practice is located in a retail center near a busy intersection with plenty of visibility and building signage. Practice features an intra-oral camera, Digital x-rays, a Pano, and most equipment is 10 years old. Long-term staff, 20 new patients per month. Practice accepts some PPO plans, no HMO. #CA295 - Steve Caudill - 951-314-5542.

**HUNTINGTON BEACH** – General Dentistry Practice with 5 Operatories has been established for 28 years in this beach-side community. Located in a professional building, the practice features Digital x-rays, Pano, Laser, Intra-Oral Camera, and long-term staff with 12 days of hygiene per week. 2014 Gross Receipts of \$1.1M+. #CA263- Kerri McCullough - 949-300-0312.

**HUNTINGTON BEACH** – This General Dentistry Practice with 3 Operatories, 2 Equipped, has 18 years of Goodwill. The practice is near residential, shopping, and freeway. 2014 Gross Receipts of \$396K on 4 days per week. This is a PPO/Fee for Service Practice. #CA277- Kerri McCullough - 949-300-0312.

**INLAND EMPIRE** – Endodontic Practice – This almost paperless 4 Operatory practice features 8 year new equipment, digital x-rays, and Cone Beam CT. The practice has 60+ years of goodwill and is near freeway. 2014 Gross Receipts of \$739K on 4 days/week with low overhead. #CA281- Steve Caudill - 951-314-5542.

**INLAND EMPIRE** – General Dentistry Practice with 7 Ops in 3,000 sq. ft. Practice features Dentrrix, digital x-rays, and Pano. 30 years of goodwill. 4½ days of hygiene per week. PPO and 2 HMO plans accepted. #CA283 – In Escrow. Kerri McCullough - 949-300-0312.

**INLAND EMPIRE** – General Dentistry Practice with Four Operatories, Intra-Oral Camera, Digital X-rays, and Pano. Located in a beautiful professional center, this practice's 2014 Gross Receipts were \$534K and Adjusted Net Income of \$196K. Seller is retiring. #CA285 – Think Tran – 949-533-8308.

**LAGUNA BEACH** - *NEW LISTING* - General Dentistry, 5 Ops, 3 Equipped, great location! \$503K GR in 2014. For more information, Call Think Tran - #CA304 - 949-533-8308.

**LOS ANGELES** – General Dentistry Practice with 6 Operatories, 5 Equipped, in a free-standing building. Practice has been established for over 50 years, in current location for 29. Utilizes SofiDent with 7 workstations, Schick Digital X-Rays, and an Intra-Oral Camera. Majority of specialty work is referred-room to grow. 2014 Gross Receipts of \$591K. #CA255- Kerri McCullough - 949-300-0312.

NORTHERN CALIFORNIA OFFICE  
1.800.519.3458



www.henryscheinppt.com

SOUTHERN CALIFORNIA OFFICE  
1.888.685.8100

# DENTAL PRACTICE BROKERAGE

*Making your transition a reality.*



Kerri McCullough  
License #01382259  
(949) 566-3056  
35 Years in Business



Mario Molina  
License #01423762  
(949) 675-5578  
35 Years in Business



Jaci Hardison  
License #01927713  
(949) 675-5578  
26 Years in Business



Steve Caudill  
License #00411157  
(951) 314-5542  
25 years in Business



Tinh Tran  
License #01863784  
(949) 675-5578  
11 Years in Business

More than  
75 Years of  
Experience!

PRACTICE SALES • PARTNERSHIPS • MERGERS • VALUATIONS/APPRISALS • ASSOCIATESHIPS • CONTINUING EDUCATION

**LOS ANGELES** – Endodontic Practice – This Endo practice with 4 Operatories has been established for over 30 years and utilizes Easy Dental and a Cone Beam. Practice's Gross Receipts for 2014 were \$360K on 21 hours per week. #CA259- Kerri McCullough - 949-300-0312.

**PALM DESERT** – This five-operator General Dentistry practice has been established in Palm Desert for 32 years and is located in a free-standing building. This retiring dentist sees 18 new patients per month and has 6 days of hygiene per week with 2014 Gross Receipts of \$842K and \$339K Adjusted Net. #CA245- Kerri McCullough - 949-300-0312.

**PASADENA AREA** – *NEW LISTING* – General Dentistry practice with 3 Operatories, Dentrax, Dexis Digital X-rays, and a CEREC. The practice has been established for 50+ years. #CA282- Kerri McCullough - 949-300-0312.

**PICO RIVERA** – This General Dentistry practice with 6 Operatories has been established since 1960. Practice utilizes DentiSoft software, an Intra-Oral Camera, and a Pano. Practice has 4½ days of Hygiene per week and 2014 Gross Receipts were \$690K. #CA258- Tinh Tran - 949-533-8308.

**SAN GABRIEL VALLEY** – *NEW LISTING* – General Dentistry. 4 Ops, 50+ years in the community. 2014 GR of \$159K, room to grow. PPO/DentiCal are taken in this practice. Tinh Tran – 949-533-8308.

**SANTA BARBARA** – *NEW LISTING* – This General Dentistry Practice with 4 Operatories has been established for 40+ years in beautiful Santa Barbara. Practice has long-term staff and 8 days of hygiene per week. Fee For Service/Delta Premier only. 2014 Gross Receipts were \$827K. #CA291-Kerri McCullough – 949-300-0312.

**SOUTH ORANGE COUNTY** – Pediatric Dentistry – This Pedito practice has 4 Operatories, and 1 year new equipment and features a beautiful, modern design, OpenDental, Digital X-Rays, and Pano. 2014 Gross Receipts were \$236K on a 4 day work week with room to grow. #CA222- Tinh Tran - 949-533-8308.

**SOUTH PASADENA** – This General Dentistry Practice with four operatories, three equipped, is in a 1,150 sq. ft. suite. This is a paperless, digital practice utilizing Dentrax, an Intra-Oral Camera, and a Laser. 37+ years of goodwill with loyal, long-term staff and 4 days of hygiene per week. 2014 Gross Receipts of \$856K with \$271K Adjusted Net. #CA244- Tinh Tran - 949-533-8308.

**UPLAND** – General Dentistry Practice with 4 Operatories, 3 Equipped, 1 Plumbed, has been established for 25+ years. Practice is located in a Professional Building and features Open Dental, Digital X-Rays, and Intra-Oral Camera. Most equipment is approximately 4-6 years old and most specialty work is referred out. #CA254- Kerri McCullough - 949-300-0312

**VICTORVILLE** – General Dentistry practice with 3 Operatories plus 3 plumbed for expansion is located in a 2,150 sq. ft. suite. Practice utilizes SoftDent software with 2014 Gross Receipts of \$273K. Practice has been established for over 34 years. #CA149- Kerri McCullough - 949-300-0312

**WEST HOLLYWOOD** – *PRICE REDUCED* - This General Dentistry practice with 4 Operatories is located in a Professional Building with 9 years of goodwill. Practice utilizes an Intra-Oral Camera, Digital x-rays, and a Laser. The average age of the equipment is 5 years old. 2014 Gross Receipts of \$571K with \$221K Adjusted Net Income. #CA212- Kerri McCullough - 949-300-0312.

**WEST LOS ANGELES** – General Dentistry practice with 4 Operatories is located in a 1,500 sq. ft., newly built-out suite in a desirable high-rise on LA's west side. Retiring doctor has practiced in the area for over 50 years. This is a **SOLD** strategy fee for Service practice utilizing Easy Dental, Digital x-rays, and an Intra-Oral Camera. Most specialty work is referred out. In 2014, the Gross Receipts were \$651K. #CA226- Kerri McCullough - 949-300-0312.

**WHITTIER** – This General Dentistry practice has been established for over 50 years in a professional building on a main street. 4 Operatories, 3 equipped. Practice utilizes Dentrax and Dexis Digital X-rays. The majority of all specialty work is referred out. 2014 Gross Receipts of \$217K - room for growth. PPO/FFS office with favorable rent. #CA276- Kerri McCullough - 949-300-0312.

## SAN DIEGO

**CHULA VISTA** – This General Dentistry practice was established 50 years ago, and the seller acquired it 35 years ago. The practice features 4 Operatories, has 3½ days of hygiene, and Dentrax Software. \$493K 2013 Gross Receipts, seller is retiring. #CA109- Russ Okihara - 619-694-7077.

**CHULA VISTA EAST** – *NEW LISTING* – General Dentistry practice with 3 ops has 2 days of hygiene per week. Call for more information. #CA302 - Russ Okihara - 619-694-7077.

**DOWNTOWN SAN DIEGO** – Leasehold sale: This modern and chic downtown office is in a prime location with excellent foot-traffic and exposure in a business/tourist area. Office features 3 Operatories, with room for expansion. Location is prime for a dentist looking to relocate or to build a practice in a very busy part of Downtown San Diego. #CA232- Russell Okihara - 619-694-7077.

NORTHERN CALIFORNIA OFFICE  
1.800.519.3458



www.henryscheinppt.com

SOUTHERN CALIFORNIA OFFICE  
1.888.685.8100

# HENRY SCHEIN®

## PROFESSIONAL PRACTICE TRANSITIONS

# DENTAL PRACTICE BROKERAGE

## Making your transition a reality.

PRACTICE SALES • PARTNERSHIPS • MERGERS • VALUATIONS/APPRISALS • ASSOCIATESHIPS • CONTINUING EDUCATION

**ESCONDIDO - NEW LISTING** – General Dentistry Practice with 4 Ops, 3 Chairs in Central Escondido. Doctor is retiring. This is an excellent opportunity to merge or grow, looking for a quick sale. #CA292- Russell Okihara – 619-694-7077

**LAJOLLA-NEW LISTING** – Quality-driven General Practice with three Operatories. This is a Fee for Service and Delta Premier Practice with a part-time Hygienist. 2014 Gross Revenue of \$559K, Dentist is retiring. #CA278 - Russell Okihara - 619-694-7077

**NORTH COUNTY COASTAL** – This General Dentistry is a Fee for Service/PPO Practice with 3 Operatories featuring Dentrrix, and Digital X-Rays. Practice is located in a highly desirable and convenient location. The owner is relocating. 2014 Gross Receipts of \$530K with \$228K Adj. Net. #CA253- Russell Okihara - 619-694-7077.

**NORTH COUNTY INLAND** – Highly-regarded General Dental Practice. FFS/PPO. 6 Operatories located in a beautiful, free-standing building with ample parking. Opportunity for property ownership. #CA271- Russell Okihara - 619-694-7077.

**SAN DIEGO** – This retiring General Dentist is in a convenient, highly-desirable area of San Diego. The practice features 3 Operatories, with dentist utilizing 2 Operatories. This is a small, quality Fee for Service practice utilizing PracticeWorks. This will be an ideal starter practice or additional boutique location. #CA161 - Russell Okihara - 619-694-7077

**SANTEE** – This General Dentistry practice is a PPO/Fee for Service office with 6 Operatories and is located in a shopping center with great retail anchors. The practice features Dentrrix software and Digital x-Rays. \$780K Gross Receipts in 2014. High-volume practice with 7 days of hygiene per week, and long-term staff. The Dentist is retiring. #CA228 - Russell Okihara- 619-694-7077

**SOUTH BAY AREA, SAN DIEGO – PRICE REDUCED**-General Dentistry practice with 3 Operatories and 4 days of hygiene per week is available in the South Bay area of San Diego. The practice is located in a well-visited retail center with great visibility and utilizes Dentrrix and Digital Pano. This is a PPO and Fee for Service practice with 2014 Gross Receipts of \$526K. #CA206- Russell Okihara - 619-694-7077.

### OUTSIDE OF CALIFORNIA

**MAUI, HAWAII – NEW LISTING** –General Dentistry Practice with a spacious layout, 7 Operatories, 5 equipped. Lots of Goodwill, Computerized, FFS/PPO with a Modern design and CEREC. Excellent Location in central Maui. 2014 Gross Receipts over \$1.4MM. #HI101-Russell Okihara – 619-694-7077.

**OAHU, HAWAII – NEW LISTING** – Modern General Dentistry Practice, with 3 Operatories. Practice is computerized with Dentrrix, and digital X-rays. This is a FFS/PPO practice. This is an excellent opportunity. #HI100-Russell Okihara – 619-694-7077.

**OAHU, HAWAII – NEW LISTING** – General Dentistry practice with 3 Operatories. Practice utilizes Dentrrix, Dexis Digital X-rays, located in a shopping center. Established for 28 years, on most major PPOs. 2014 Gross Receipts over \$360K. #HI102-Russell Okihara – 619-694-7077.

### NORTHERN CALIFORNIA

**BENICIA** - General Practice & Building. 1,545 sq. ft., 4 ops, Open Dental software, digital X-ray & Pan, Laser. 2014 GR \$550K. #CA298 Jim Engel - 925-330-2207.

**CALAVERAS COUNTY**– General Dentistry – 4 Op office, 1,752 sq. ft. w/Dexis Digital X-ray, Eaglesoft, Cerec, and Pano. Av. GR last 3 years \$450K. #CA294-Dennis Hoover - 209-605-9039.

**CASTRO VALLEY** - General Dentistry - Practice & Building. 1,500 sq. ft. 3 equipped Ops, 1 add'l plumbed. 2014 GR of \$373K on 4 days/week. #CA251 Jim Engel - 925-330-2207.

**FOLSOM** – General Dentistry - 2,420 sq. ft. w/5 Ops, Schick X-rays, non-digital Pano, Softdent. #CA235-Thomas Wagner - 916-812-3255.

**FOLSOM – FACILITY ONLY** - 1,200 sq. ft. with 3 Ops, digital x-rays & pano. #CA209-Thomas Wagner - 916-812-3255.

**GREATER PITTSBURG AREA – PRICE REDUCED** by \$122,000 - General Practice + Bldg. 7 Ops, 2,324 Sq. Ft. 2012 GR \$885K #CA108 Thomas Wagner - 916-812-3255.

**GREATER ROSEVILLE/ROCKLIN/LOOMIS** – General Practice. 1,500 sq. ft., 5 Ops (4 equipped), Dexis, Dentrrix. #CA239 - Thomas Wagner - 916-812-3255.

**GREATER SACRAMENTO** – General Dentistry - 7 Ops, 3,079 Sq. Ft. (Shared w/2nd DDS – Separate Practices), 2013 GR \$974K. #CA140- Thomas Wagner - 916-812-3255.

**GREATER SACRAMENTO** – General Dentistry - 2,100 sq. ft. w/6 Ops, Dentrrix. Combined 2013 GR of \$1.1MM. #CA237 - Thomas Wagner - 916-812-3255.

**GREATER SAN JOSE AREA** – Perio Practice. Fiscal-year GR \$1.3MM. 5 Ops, 2 add'l plumbed, in same loc. 28 years. #CA219-Dennis Hoover - 209-605-9039.

**LIVERMORE** - General Practice & Building. Approx 1,100 sq. ft., 4 ops w/Digital Pan, Digital X-ray, Laser, Dentrrix software. 2014 GR \$740K. #CA300 Jim Engel - 925-330-2207.

**MARIN COUNTY** – Mill Valley 1,260 sq. ft. 3 Ops, 1 add'l plumbed. Dentrrix, Digital, Intra-Oral. #CA224-Jim Engel - 925-330-2207.

**MARIN COUNTY** – General Dentistry- 3 Op practice. 2014 GR\$315K. Paperless charts, Schick Digital Sensors, Eaglesoft software. Owner retiring. #CA286-Jim Engel - 925-330-2207.

**MARIN COUNTY – NEW LISTING** - 1250 sq. ft. 3 operatories. Fee for service 2014 GR \$370,000, on pace for same in 2015. #CA302 Jim Engel - 925-330-2207.

**MILLBRAE** – General Dentistry- 1,500 Sq. Ft. leased office with 5 Ops, 1 additional plumbed, state-of-the-art equipment. 2014 GR \$670K. #CA262-Jim Engel - 925-330-2207.

**NORTH COAST** - Endo Practice. 6 Ops, 5 plumbed 3,300 sq. ft. Digital, Microscopes, EndoVision. #CA214-Jim Engel - 925-330-2207.

**NORTH EAST OF SACRAMENTO** – 2,500 sq. ft., 7 Ops with intra-oral, digital x-ray, and Eaglesoft software. 2014 GR \$1.5M. #CA268-Thomas Wagner - 916-812-3255.

**NORTH OF SACRAMENTO** – 1,750 sq. ft. office w/4 Ops. Intra-Oral, Digital X-ray, Pano, Laser, CAD-CAM, & Dentrrix software. 2014 GR of \$1M. #CA260-Thomas Wagner - 916-812-3255.

NORTHERN CALIFORNIA OFFICE  
1.800.519.3458



www.henryscheinppt.com

SOUTHERN CALIFORNIA OFFICE  
1.888.685.8100



# HENRY SCHEIN®

## PROFESSIONAL PRACTICE TRANSITIONS

# DENTAL PRACTICE BROKERAGE

Making your transition a reality.

PRACTICE SALES • PARTNERSHIPS • MERGERS • VALUATIONS/APPRISALS • ASSOCIATESHIPS • CONTINUING EDUCATION

**NORTH OF SACRAMENTO** – 1,324 sq. ft. office w/4 Ops, Dentrix software, Pano.. Owner worked 39 weeks in 2014. #CA267-Thomas Wagner - 916-812-3255.

**NORTHERN CALIFORNIA** – Perio Practice, Partnership Position. 6 Ops, 1,500 Sq. Ft. Dentrix. Owner Financing Available. #CA168-Thomas Wagner - 916-812-3255.

**NORTHERN CALIFORNIA** – Endo Practice. 3 Ops, 1 Plumbed, 1,200 Sq. Ft. 2 Microscopes, Digital. 2013 GR \$319K. #CA158- Thomas Wagner - 916-812-3255.

**NORTHERN SACRAMENTO** – 3 Ops in a leased space with <1,000 sq. ft., PPO practice, 2 days hygiene, digital x-rays & Easy Dental software. #CA266-Thomas Wagner - 916-812-3255.

**OAKLAND** – General Dentistry- Appx. 1,500 sq. ft. w/4 Ops, Dentrix software, Dexis Digital X-ray. 2014 GR \$869K, adj. net \$370K, 5 day week. #CA293-Jim Engel - 925-330-2207.

**OROVILLE** – General Practice. 1,000 sq. ft., remodeled 2010. Dentrix & Dentrix software, Digital Pan & X-rays, Laser, Intra-Oral. 2014 GR \$512K. #CA287-Dennis Hoover - 209-605-9039.

**OROVILLE** – General Practice. 3 Ops, mostly new equipment & recently remodeled. Great satellite or startup practice. Owner retiring. #CA288-Dennis Hoover - 209-605-9039.

**OAKLAND** - General Practice. Piedmont District. 3 Ops in **SOLD** office w/1,600 sq. ft. GR\$453K. #CA217 Jim Engel - 925-330-2207.

**PITTSBURG** – General Dentistry- 3 year avg. GR of \$236K w/60 **SOLD** Overhead. 5 Ops in 1,400 sq. ft. with Pano. #CA133- Jim Engel - 925-330-2207.

**PINOLE** – Endodontic Practice.- 4 Op Endo office w/Digital X-ray, Microscopes, and PBS Endo software in approx. 1,200 sq. ft. 2014 GR \$672K. #CA284- Jim Engel - 925-330-2207.

**PLEASANTON** – Facility Only, Former Endo Ofc, Good GP Startup. 2 Ops, 1 Plumbed & Partially Eq. 975 Sq. Ft. #CA195-Jim Engel - 925-330-2207.

**SACRAMENTO** – General Practice: 1,320 sq. ft. w/ 3 equip. ops, 1 add'l plumbed, Dexis Digital X-ray, Intraoral, Carestream software. 2014 GR \$434K. #CA296-Thomas Wagner - 916-812-3255.

**SACRAMENTO** – 7 equip Ops in 2,400 sq. ft., 1 add'l Op plus **SOLD** Pano, Softdent, Digital. 2014 GR \$626K+. #CA250-Thomas Wagner - 916-812-3255.

**SACRAMENTO** – Practice and Condominium. 1,300 sq. ft. office, 4 Ops. Eaglesoft software. 2014 GR \$650K. #CA261-Thomas Wagner - 916-812-3255.

**SACRAMENTO** – 1,684 sq. ft., 6 equip. stations in bay, 2 add'l plumbed. 2014 GR \$590K. #CA269-Thomas Wagner - 916-812-3255.

**SACRAMENTO** – General Practice: Russian-speaking. 4 Ops, 1,500 sq. ft. All new equipment, practice started 1.5 years ago. \$1M GR YTD through October. #CA290-Thomas Wagner - 916-812-3255

**SACRAMENTO** – General Practice: 2,500 sq. ft., 6 equip. Ops, 1 add'l plumbed. Dentrix software, Digital X-ray, Intra-oral, Pano. 2014 GR \$788K. #CA297-Thomas Wagner - 916-812-3255.

**SAN FRANCISCO** – Periodontal Practice & Condo Unit. 1,160 sq. ft. w/4 Op, 2014 GR \$714K w/\$363K Adj. Net. #CA274-Dennis Hoover - 209-605-9039.

**SANTA MARIA** – 4 Ops, Easy Dental, Dexis, and Intra-oral camera. **SOLD** 2013 GR of \$523K in 180 Dr. days. #CA166- Jim Engel - 925-330-2207.

**SANTA ROSA** – General Dentistry & Building. 3 Ops. 2013 GR \$542K w/Adj. Net \$182K. #CA200-Dennis Hoover - 209-605-9039

**SOLONO COUNTY** – General Practice: 1,350 sq. ft., 4 Ops, Intra-Oral, Digital, Pano, and Dentrix. 2014 GR of **SOLD** \$69K on 30 hour/week. #CA246-Thomas Wagner - 916-812-3255

**SONOMA** – Stand-alone 2,000 sq. ft. office w/4 Ops. Digital X-rays, Lasers, CAD/CAM. 2014 GR \$675K on 3 day/week. #CA270- Jim Engel - 925-330-2207.

**SOUTHERN SACRAMENTO COUNTY** – General Practice: Condo office with 1,380 sq. ft. & 4 Ops, Intra-Oral, **SOLD** Dexis, Pano, Laser, Easy Dental. 2014 GR were \$581K #CA249 -Thomas Wagner - 916-812-3255.

**WALNUT CREEK** – Prosth Practice. 3 Ops, Full Lab. 2013 GR \$399K w/Adj. Net \$143K. #CAM540- Jim Engel - 925-330-2207.

**YOLO COUNTY** – *NEW LISTING* - Pediatric practice with 2 equip. Op, approx. 1,000 sq. ft., Intra-oral, Open Dental software. 2014 GR \$245K. #CA301-Thomas Wagner - 916-812-3255

### CENTRAL CALIFORNIA

**CENTRAL COAST** – General Practice in the Central Coast area. 31 years of goodwill. 6 Ops, 8 days of hyg/week. 2013 GR of \$2.3MM and Adj. **SOLD** Net of \$840K. Dentrix, Digital, Paperless, Intra-Oral Camera, Laser. #CA208-Kerri McCullough - 949-300-0312.

**FRESNO** – General Practice. 4 Ops, 1,739 Sq. Ft. CEREC, **SOLD** Overhead. 2013 GR \$740K+. #CA202-Dennis Hoover - 209-605-9039.

**KINGS COUNTY** – *NEW LISTING* - Practice has been est. 50 years in a rural community. 4 Ops, intra-oral camera, and Pano. 2014 GR were \$246K. Great location to relocate or open a 2nd office. #CA265 - Steve Caudill - 951-314-5542.

**MADERA** - General Dentistry –Building & practice. 6 Ops, 3000 sq. ft., Dentrix software, Dexis software, Pano. 2014 GR \$850K. #CA289-Dennis Hoover - 209-605-9039.

**PASO ROBLES** – Modern 4 op, 1,998 sq. ft. office with Digital X-ray, Softdent software. 2014 GR \$573K+. **SOLD** #CA275 - Jim Engel - 925-330-2207.

**PORTERVILLE** – General Dentistry with 6 Ops in a 2,600 sq. ft. suite located in a retail center. 2014 GR of \$555K. 7 year new equipment, intra-oral camera, Pano, PracticeWeb. #CA223-Steve Caudill - 951-314-5542.

**TULARE** - 2,300 sq. ft. free-standing office w/5 Ops. 2014 GR \$1.7M. 10 days hygiene. Owner moving out of state. **SOLD** #CA273- Dennis Hoover - 209-605-9039.

**TUOLUMNE COUNTY** - General Practice & Bldg. 6 Ops, **SOLD** Sq. Ft. 2013 GR \$1MM+ #CA199- Dennis Hoover - 209-605-9039.

NORTHERN CALIFORNIA OFFICE  
1.800.519.3458



www.henryscheinppt.com

SOUTHERN CALIFORNIA OFFICE  
1.888.685.8100

# Free Consultation

*PROACTIVE* **SEO** *SOLUTIONS*

## LET US BUILD YOUR ONLINE FOUNDATION

### Our Services Include

- Responsive Website Design
- SEO ( Search Engine Optimization )
- PPC (Pay Per Click)
- Social Media Management
- Reputation Management
- Video Production
- Phone Tracking
- +more

# Call (310) 994-1136

**PRACTICE SALE VALENCIA.** Retirement. Established general dental practice. 4 operatories. \$300,000+ collections on part-time 3 days/week. Seller motivated. Broker - Charles Kim 800-416-2055.

**Taylor Liao** Manager of Kings Two Dental Supply (City of Industry, CA)-What can I say about him? He's the lawyer we go to when we need a lawyer. Dr. Chester Jeng of Law Offices of Jeng and Associates is very personable and knowledgeable in dentistry and law. He's definitely a straight shooter, he tells you what you need to know and also what you probably do not want to hear. He's the one we go to if we need a lawyer. Call Jeng & Associates 714-858-0536.

**Dental receptionist needed** in Beverly Hills Dental Practice. Please call 310-994-5336 and leave a voice message.

**ITERO for sale** Upgrading to Element, \$10k, full warranty and free training included from Align. drhoffman@nportho.com, 818-970-8216 cell.

**UCSF Dentist** looking to buy or work then buy office in Los Feliz or generally west of 101. 872.222.8722.

**CLOUD BASED TELEPHONE SYSTEMS** for Dental Offices. Simple, flexible, and powerful voice and data solution at a very affordable price. Cutting edge technology allows dental offices to utilize a fully hosted PBX and offer you the latest phone and Internet technologies without the need and cost to purchase your own onsite PBX. Call 800-273-5033. Or visit: www.eZ2000dental.com, then PRODUCTS, then TELEPHONE / INTERNET SYSTEMS.

**Associate Specialist wanted** Interested in a starter or branch office? 2 turnkey offices avail, San Pedro & Torrance. (310)502-4619 John.

**Practice and building** for sale in Huntington Park by owner. Great location, huge opportunity. jakesaedi@gmail.com or 310-963-7675.

**ASEPTICO AIRPAC** Air Compressor AA-74SA-110, Like New, Original Cost \$900, Make Offer 855-772-7645 or janetm@hygiacare.com.

**NEED GENERAL DENTIST** LIKE WORK WITH CHILDREN IN BAKERSFIELD. luismico1@hotmail.com 6613272155 6613274122.

**DENTAL PRACTICE FOR SALE** SF VALLEY: Must see Shopping Center Opportunity. Call Broker - Practice Sales & Appraisals (818) 999-9595.

**Need Administrator** for progressive practice in OC with satellite locations. Detail-oriented and administrative duties including treatment details. Experience only. Lovedentistry2015@gmail.com.

**Dentistry for sale** in Hollywood, CA! 2 op rooms, X-Ray room, rent \$1000. \$40,000 OBO. Call 323-620-8306 Aida.

**Burbank office sale** 1350 sqf, 3 op, digital, busy shopping center, 2014 collection \$320K. Price \$260K. dentalhome99@gmail.com.

**Cecilia Chen, Esq.** is very knowledgeable in dental law, particularly when it comes to partnership buyouts and practice acquisition. - Richard Lindsay, DMD. Call us for a complimentary consult. Toll Free: 855-850-4111, Cecilia@practice-atty.com or www.practiceatty.com.

**Nice dental office** for sale/rent in National City. Located in a highly traffic area. Only interested buyers. Contact 619-370-1053.

**Pedodontist needed** in South Orange County. Oral Sedation. Private office. 3-4 children/day. All PPOs. Email psmgmts-vcs@yahoo.com.

**BAKERSFIELD #31** (4) op comput. G.P. & free stand. Duplex Bldg. for sale. Excellent signage & visibility. (3) ops eq't'd / (4th) plumbed. Cash/Ins/PPO pt base. No HMO & no Denti-Cal. (46) years of Goodwill. Annual Gross Collections approx \$350K. Office does no advertising. Refers out all Ortho, Perio Surgery, Implant Placement, complicated Endo & O.S. D&M Practice Sales 818.591.1401.

**Dental office** in Huntington park looking for treatment coordinator / biller, Bi lingual with great people skills. call (310) 384-4360.

**\*\*\*HUNTINGTON PARK PRACTICE\*\*\*** w/ Real Estate for Sale  
Greg Beamer, 909-542-4891.

**Endodontists available at your office. We will bring our equipment, supplies, microscope, assistant. NO INVESTMENT needed on your part.**  
smartendo1@gmail.com.

**West Covina** Starter Practice collected \$200,000 in 2014 and \$100,000 for the first 4 months of this year. Free standing building. 3 equipped ops. Asking \$100,000. Kurt Skarin 805-777-7707.

**Tarzana** Gorgeous modern practice for sale. 3 ops, digital Panoramic, great lease, low rent & overhead, free parking, asking \$297K. robert21b@yahoo.com.

**PRACTICE FOR SALE NEW!!** GP in VISTA along VERY busy street. 4 Ops (3 equipped) in 1400 sq.ft. DIGITAL & PAPERLESS. Panorex. Insurance and Cash. SDPS: 760-599-7828.

**PRACTICE FOR SALE** BAKERSFIELD GP 18 yrs gdwll w/ 6 ops Net \$108K. California Practice Sales, Inc. Phone: 714-639-2775.

**Are you looking** for an Oral Surgeon, Periodontist or Endodontist to team up at your office? Contact Synergy Specialists. Our network has a full team of two dozen of the most clinically efficient, team work frame minded specialists in the industry motivated to team up with offices.  
info@synergyspecialists.com.

**Just starting?** Rent a space / Operatory space 1 or 2 days a week. Artesia area. Call:(562)402-4952 - Pearl.

**Purchasing your new practice** call Bob Affleck @ Citi Practice Finance he will be your biggest advocate 949-939-4550.



**GB** **GREG BEAMER**  
DENTAL BROKER

The Name You Know  
The Reputation You Trust

**Greg Beamer, Dental Broker**

Experience in Finance and Brokerage since 1976

- 23 + YEARS IN DENTAL BROKERAGE • FULL-SERVICE BROKERAGE
- PROVIDES BUYER OR SELLER REPRESENTATION
- APPRAISALS AND EVALUATIONS • PRACTICE TRANSITIONS
- FINANCIAL ASSISTANCE

## Current Listings

### SOUTH RIVERSIDE COUNTY PRACTICE

(6) treatment rooms in a state of the art, spacious suite located in a busy shopping center w/ excellent exposure/ signage. Established practice attracting approx. 60+ new patients/mo. 80% Insurance & 20% Cash. Steady Collections of \$1.1 M for the past 3 years w/ a strong Buyer's Net \$350,000+.

### NEW LISTING: HUNTINGTON PARK W/REAL ESTATE FOR SALE



(6) treatment rooms in a spacious, state of the art, nicely designed 2,900 sq. ft. suite close to downtown Huntington Park. Dental Suite is on the bottom floor w/ 3 rental units on the second floor. Ample parking for patients and staff. Well-maintained property with good curb appeal. Projecting approx. \$645,057 for 2015.

### RANCHO CUCAMONGA PRACTICE



(3) treatment rooms and (1) plumbed not equipped in a 1,600 sq. ft. suite. 2nd story location in a professional multi-building complex on a busy street w/ heavy daily traffic. Rent is very reasonable and all inclusive at \$2,900/mo. Sellers have a second practice in Hesperia. Established in August of 2013, the practice is open 2.5 days a week and has approximately 600 active charts. You will not believe the price! **Backup Offers Encouraged.**

### NEW LISTING: TRABUCO CANYON ORTHO/PEDO LOCATION



Beautiful, serene area in Orange County across from O'Neill park surrounded by rolling hillsides. The spacious, nicely designed, modern suite offers (4) Royal

Model ORII chairs in an open bay. Located in a single story, small strip shopping center with a GP next door. Excellent Signage, ample parking & the rent is \$1,743/mo. Seller has two other practices that he would like to concentrate on. A peaceful place to practice.

**Build-Out Opportunities in Los Angeles  
(Hispanic Area), Paramount, and Victorville**



### WHITTIER PEDO PRACTICE

(4) eq. chairs in an open bay, (2) eq. treatment rooms, & (1) exam chair in a private office for consultations in a 1,800 sq. ft. suite located in a two story professional building. Established in the area for 12 years. The buyer has the opportunity to grow the Pedo base given the numerous area referrals and the current schedule of 1 day a week.



### HUNTINGTON BEACH LOCATION

(3) treatment rooms, (2) consultation rooms, (1) recovery room, and plumbed for (2) additional treatment rooms in a 1,800 sq. ft. suite located in a two story medical/professional office building off a busy street. Currently an Oral Surgery Practice. The location could be a successful GP or Specialty Practice. The landlord is prepared to draft a new fair-market value lease. Selling as a Leasehold Improvements and Equipment Only. Motivated Seller will entertain any reasonable offer, and will provide O/S opportunity if buyer is a GP. Priced to Sell!

### PASADENA PRACTICE

High income GP practice in a 2,200 sq. ft suite - multi-story medical dental building. Convenient to the 110, 210 and 134 freeways. 19 year practice is projecting \$1MM plus for 2015. (6) treatment rooms and (1) plumbed not equipped. Solid patient base and a strong buyer's net. **Listed, advertised and under offer within 17 days.**

### NEW LISTING: WEST LA PRACTICE

(4) treatment rooms in 980 sq. ft. suite located on a busy street w/ excellent exposure and off street parking. Attracting 25+ new patients per month. PPO/ Cash Practice. Well established, community practice w/ an outstanding reputation for quality care.

Ph: (909) 542-4891 • Fax: (866) 890-1033

info@gregbeamer.com • www.gregbeamer.com

**Ronadro** "Dentistry Past" statue for sale \$3995! Near-perfect condition; custom name plate available. Call Dr. Jerry Young to inquire: 714-680-3063.

**Looking to buy** dental practice est. 25 years from retiring dentist in Hollywood? Call 323-663-8842.

**Why Give Up** Your Patients To Other Dentists? Have All Undoable RCTs Done At Your Office. Visit [www.socalrootcanal.com](http://www.socalrootcanal.com).

**Coachella Valley** assoc available. Semi-retired dentist looking for a quality office with purchase option. No HMO/Denti-cal. (310) 502-4619 John.

**Dental office** 12 years established, ready to lease or sale, Santa Ana on major street Ranjan Patel 714-931-5785.

**DENTAL PRACTICE FOR SALE** IN LOS ANGELES GP in shopping center. Major anchor stores. 7 operatories, 2,300 sqft. #LA70A. Call Loc Pham, Broker at LCF BRE#01875780. (714)550-7494 or [practice@lcffin.com](mailto:practice@lcffin.com) | [LCFPracticeSales.com](http://LCFPracticeSales.com).

**Oral Sedation** adults and kids in your office. 25 years experience, all equipment, documentation, supplies provided. San Diego area [gfinn@dslexreme.com](mailto:gfinn@dslexreme.com).

**All County** was great throughout my entire const. Project. Couldn't have been any smoother. Dr. D Ghorab. 714-240-7179.

**Econo-Vac** suck down heater (vacuformer) for sale, Only used lightly & working great \$299 OBO 3109805265.

**Managing Dentist** opportunity. Indio location ready to open. Serious inquiries only. Send resume [info.coachelladentalgroup@gmail.com](mailto:info.coachelladentalgroup@gmail.com).

**Paige Heatherly** RDH I am a hard working, team player individual looking for work in Inland Empire. (559)676-0898.

**FRONT DESK** RECEPTIONIST W/EXPERIENCE NEEDED IN NEW DENTAL OFFICE IN NORTH HOLLYWOOD. EMAIL [DELHART@GMAIL.COM](mailto:DELHART@GMAIL.COM).

**general dentist** pedo experience needed Hemet area busy pedo office immediate opening good compensation email us at [dentistry4kid@gmail.com](mailto:dentistry4kid@gmail.com).

**General Dental office space** in Carson for sharing or sublease for OS, Endo, Perio. Pano available, many parking spaces, [carsondentaloffice@gmail.com](mailto:carsondentaloffice@gmail.com).

**Massage Dental Chair** Made in USA, 150 Color Choices, 10 Year Warranty \$3495. Call (800) 423 - 5657 or visit [DHPDENTAL.COM](http://DHPDENTAL.COM) for more details.

**Private office** in Murrieta looking for an oral surgeon, wisdom teeth ext. and implants, minimum two years experience. [ddmurrietadmd@yahoo.com](mailto:ddmurrietadmd@yahoo.com).

**Ortho Sub!** Need to take a break? Keep your office open! Call Kathleen - 626.590.9327.

**HUNTINGTON BEACH** General Practice. 5 Ops, est. 28 years, Professional building, Digital, Pano, Laser, 12 days of Hygiene/week. HSPPT-Kerri McCullough 949-566-3056-#CA263.

**FOR SALE** Midwest Quiet-Air Insight F/O Handpieces(2). Just overhauled. 6-month Warranty. Push-button head or Bur Key.(323) 851-6622.

**Hospital Grade** Synthetic exam gloves \$39.68 per case of 1,000, Nitrile "Sensicare Silk" exam gloves \$171.05 per case of 2,500 (boxes of 250). That's \$.07 per glove! [www.dentalprodx.com](http://www.dentalprodx.com)

**"Jason, thank you** so much for revising and reviewing my dental contract. I now have a comfortable sense of security." EVA K. SWENSON, DDS. CALL TODAY 800-499-1474 WOOD & DELGADO [www.dentalattorneys.com](http://www.dentalattorneys.com).

**Dental Hygiene** Instruments and Cassettes for Sale. Email [dara-bantp@yahoo.com](mailto:dara-bantp@yahoo.com) for photos. \$1,200.

**Pedo practice for SALE in Woodland Hills, CA--collected 133K in 2014 huge growth potential-4 fully equipped ops in newly remodeled office --good lease motivated seller will assist in sale and financing --818-599-4274.**

**Vista** 6 Ops. 1,500 Sq ft. 26 yrs. of Goodwill. Office Condo for sale also. Seller retiring. Located in Professional bldg. Ken Rubin Practice Sales (619) 299-6161.

**Irvine dental office** sublease, or lease Avilabel for specialist and general dentist in Irvine center drive state of art.949-7352064.

**GENERAL DENTIST** Van Nuys & Pasadena office needed. min 2yrs experience working with kids & adult. email: [sinai.dental@yahoo.com](mailto:sinai.dental@yahoo.com) fax : 818-780-7575.

**Thank you for your patience** in helping me and my family select the proper medical coverage! So many options but with your help we finally have the right one! – Todd Brilliant DDS, San Diego. [www.TheDoctorsInsuranceBroker.com](http://www.TheDoctorsInsuranceBroker.com), [jonathan@tdibroker.com](mailto:jonathan@tdibroker.com) or call 800-767-0864.

**4 op remodeled office** near LAX in Westchester Medical Plaza. Views of planes, ample parking, fully equipped! (310) 577-5888.

**NEED A CPR CARD?** We come to you! Earn 4 CE units and get a 2 year card. Fast and affordable training for the whole staff. Go to [CPR4DENTISTS.COM](http://CPR4DENTISTS.COM) or call (626)797-6179, ask for Danny.

**Can't find what you're looking for?** Call Bruce at The Dental Trader! I've been building a database of dental companies and resources for over three decades. If I can't help you locate it, it probably doesn't exist anymore. I'm here to help. 877 888 4237.

**Learn Ortho!!** Your Office, Your Patients. Be mentored by an experienced and caring orthodontist. Call Kathleen. 626.590.9327.

# HANDS-ON Surgical Course

## Surgical Extractions, Bone Grafting, and Implant Placement

Limited availability. Sign up today!

4 CE UNITS

- Learn comprehensive treatment planning.
- Learn to perform difficult extractions and proper bone regeneration techniques.
- Learn the surgical placement of dental implants on pig jaws.
- Learn implant prosthetic phase.
- Learn how to manage surgical and prosthetic complications.
- Increase case acceptance.

Hands-on Course Tuition:  
Only \$499

Hands-on Course Includes:  
4 CE Units, all surgical materials,  
implants, and pig jaws.

### COURSE DATES:

Saturday, December 19, 2015  
Saturday, January 16, 2016  
Saturday, March 12, 2016  
Saturday, May 14, 2016  
Saturday, September 17, 2016  
Saturday, December 17, 2016



100% of the profits from the course are used to treat our veterans and neglected older adults living below the threshold of poverty.



This course is being conducted by a team of experienced board-certified oral surgeons, prosthodontists, and periodontists. It is led by Dr. Charles Zahedi who is faculty at the University of California, Los Angeles. Previously he was a full-time Associate Professor at the Department of Advanced Periodontics and Implant Surgery at Loma Linda University. He has been extensively involved with dental implants since 1990 and has trained hundreds of dentists around the world from Europe, Asia, South America, and the United States. Dr. Zahedi is the founder and clinical director of Dentists for Veterans and the Oral Disability Rescue. These non-profit organizations have initiated the first nationwide study on veterans and have been a pioneer in preventing abuse of older adults. Our mission is to bring about awareness of the importance of oral health care for every individual.

## Call Now 888.871.0009

info@implantmentoring.com | www.implantmentoring.com | www.implantoutreach.com

©2015 Implant Outreach Inc. All rights reserved. Implant Outreach® is a registered service mark. Do not Quote, Cite, Use or Reproduce Without Written Permission of Implant Outreach Inc.

Buy it! Sell it! Trade it!!!

**FOR SALE** Star Titan-3 Slow Speed Like New Without swivel. Motor only. Angle Adaptor and Contra Angle available. (323)851-6622.

**Beverly Hills Sublease** Beautiful, Modern, New, Fully Staffed, Fully Equipped Dental Office for Sublease. Flexible Terms. drmehr@hotmail.com, (310)962-0670.

**ASEPTICO** CompriCart ADU-20B Delivery Unit with Fiber Optic Scaler. Like New, Original Cost \$2,690 Make Offer. 855-772-7645 or janetm@hygiacare.com.

**Need to buy** digital sensor, practice software management, digital scanner. digital panorex machine. Please call 9497352064.

**GE B40** Patient Monitor Arrythmia, CO2/O2, BP Detection/ Roll Stand- Never used. \$2,500 OBO. Contact (865)657-8086, gmbdds@gmail.com

**BUYING DENTAL PRACTICES** Considering a gradual transition? Investors are seeking \$1 million/yr+ established practices. Sell discretely. Option to continue serving your own patients. Ideal plan to slow down for retirement or relieve yourself of management headaches. Please contact for consultation: Charles Kim 800-416-2055.

**zoom advanced** power plus whitening unit for sale excellent condition \$500. call 8187859944.

**Vident Glazing furnace** Automatic glazing furnace to stain, crowns for a perfect color match, asking \$450 obo, call (818) 631-8180.

**Santa Ana** dental office for sale, good location, good PPO patients, contact Gigi 714-269-7949.

**Dentist needed** Sunland. Friendly with caring personality. Production oriented while maintaining high clinical standards. Minimum 2 yrs experience. Submit resume lvfdental@gmail.com.

**Dental Associate Needed** Santa Barbara two days/week.. Partnership to Buy Out Possible Call Cecilia at 805-689-7697.

**San Fernando Valley** perio practice collects \$880,000/year with a net income of \$265,000. Four days of hygiene per week. 5 ops. Asking \$475,000. Kurt Skarin 805-777-7707.

**Beautiful office** in Yorba Linda, Orange County available for sublease. 5 ops. Ideal for specialist. Please contact us at yldental@yahoo.com.

**THE WEST'S BEST BBQ** Santa Maria – 4 exam rooms. ID#CA76583. Call Maria at Practice Concepts 877-778-2020 x. 108.

**Legal Tip** Does it matter whether the sale closes this or next year? Attorney Robert W. Olson, Jr., 805.963.1120, www.transdental.com.

**TPC** Thin X-ray Viewer(used). Countertop or wall mount \$35 each (Pick up only in Oxnard or O.C.) Coastdds@yahoo.com.

**PRACTICE SALE** Mission Viejo. Well established. \$800,000/yr collections. PPO/FFS. Large shopping center with anchor tenants. Broker - Charles Kim 800-416-2055.

**RDAs needed** for new Ridgecrest Pediatric office. Currently P/T. Send resume to gilbedan@gmail.com.

**Cecilia Chen, Esq.** negotiated a 3-months rent abatement for my practice purchase, giving me the much needed capital during the transition period. – D. Aminov, DMD. Call us for a complimentary consult. Toll Free: 855-850-4111, Cecilia@practiceatty.com or www.practiceatty.com.

**takeover** 2op burbank practice for setup/inventory price. email takeoverpractice@gmail.com your interest.

**Well-established state of the art orthodontic office in West Los Angeles seeking an experienced Pedodontist who is highly motivated and takes pride in providing high quality care. Please submit your CV to: westlaortho@gmail.com.**

**Exp DDS** for Smile Dental Group in Palmdale. 3-5 yrs exp preferred. Send CV to palmssmile@yahoo.com attn Donny Guaranteed Base!!!

**Office 4 sale** in CARSON. Newly remodeled and recently opened, Spent over \$250k. Great lease. Absentee owner health issues. carsondentaloffice@gmail.com.

**DENTAL PRACTICE FOR SALE PALMDALE:** Retiree. 20+ years of Goodwill. HMO income of \$5K/mo. Priced Right. Call Broker - Practice Sales & Appraisals (818) 999-9595.

**PRACTICE FOR SALE** APPLE VALLEY GP w/37 yrs gdwill; \$44K/mo. California Practice Sales, Inc. Phone: 714-639-2775.

**Caring endodontist** with great bedside manners needed in San Fernando. once/month. Please email resume to jysdental@gmail.com.

**gently used** dentist and assistant chairs(3 sets) for sale-\$175/set. Please contact coronadental4@gmail.com for more information.

**WEST COVINA PRACTICE** FOR SALE AND BUILDING- High quality, retiring Dr. does all facets of dentistry including some ortho and implant. 35 years goodwill - Grosses over \$800,00 on 3 ½ days/week -5 operatories in 1700 sq ft - very modern, includes Cerec – Building 3300 sq ft on 13,000sq ft lot with own parking lot - - Thomas & Fees Practice Sales (714) 544-4341.

**Dentist needed** for new community health center in Oxnard, CA. Full-time salary with benefits. Send CV to careers@clinicas.org.

**Looking for Dental Receptionist & RDA** or floor Supervisor in Los Angeles Area if interested please contact Vicky @ vortega@totalcaredentalgroup.com / 626)813-4488.

**Exodontist available** for extractions. Efficient, Friendly. Will bring instruments, Licensed CA dentist. 9 yrs experience. call 951-640-2720.

**BRE ID #01049085—NRDS ID #193519843—Realtor, Member of SRCAR**



With over 22 years of experience conducting Dental Practice and Real Estate Sales, DDS Xpress is your connection for timely Practice Sales and a fast-track to locating the right commercial, residential, or investment property.



## Featured Listings

**Hawthorne:** Store front location on a major thoroughfare, providing excellent exposure, \$380,000 in revenues. Office offers 5 ops, Pano, digital x-ray and much more

**Los Angeles County:** 6 ops. Fee for service located in a free standing building on a major street providing excellent visibility. Located on main artery from the 710 Freeway exposing the practice to thousand daily commuter. Collecting approx. \$650,000 in revenues Real Estate for sale

**West Los Angeles:** Turn-Key, Retiring Seller 3 ops. located in a free standing building on a busy corner across from the DMV. Convenient to the 405 freeway. Great Price!

**Inland Empire:** Retiring Seller. Group Solo practice w/ 38 years of Goodwill. Collecting approx. \$390,000. 4 ops. 2 hygiene days. Condo Suite for sale

**Malibu:** Store front location 4 ops. Seller motivated will consider all reasonable offers

**Panorama City:** Gross \$1,5 Mil, Practice located in busy shopping center. High foot traffic exposing the practice to an average of 150 new patients per month. Associate run practice offering services in GP & Ortho. 7 ops, digital x-ray, Pano, Eagle Soft software Call now, will not last on the market

**West Covina:** On target to collect \$1Mil. Located on the ground floor of thriving two story major shopping center with high foot traffic. 100 new patients per month Office offers 5 ops, digital x-ray, Pano & Eagle Soft software. A must see!!!

Dealing With :

High Broker Fees  
Limited Services

Long—Term  
And Restrictive  
Contracts

DDS Xpress  
Offers customized  
Service with fair  
And equitable  
Commission structures



**Office : 951-309-3196 . Cell : 951-437-0419 . Fax : 800-532-0739**

**E-Mail : [tinaochoa@ddspressrealty.com](mailto:tinaochoa@ddspressrealty.com)**



Dental Practice Sales and Transitions; Commercial/Residential Sales and Acquisitions; Real Estate Searches; Bank Owned Property (REO) Expertise; Buyer Pre-Qualification Direct Lender Referrals for acquisitions or build-out construction loans.



**Biolase C100** hard/soft tissue laser for sale. Glasses and tips included. Sshamoiei@gmail.com.

**GENDEX PANOREX ORTHORALIX 9000** was purchased 2000. film type great, condition, \$4950. Call 909-899-8757.

**Is it time to consolidate** your loans? Let's talk about how we can work together to simplify your finances. Call Wells Fargo Practice Finance at 1-888-937-2321 or visit us at wells Fargo.com/dentaltrader.

**ASSOC DENTIST NEEDED** for office in Moreno Valley. 3 yrs experienced required. Send resume to fdc22940@gmail.com.

**New dentist** looking to start or buy a practice? Call Wells Fargo Practice Finance at 1-888-937-2321.

**Looking for** an experienced general dentist in Buena Park area, part time or full time. please email resume at ufdhire@yahoo.com.

**FOR Sale** Mid-West Shorty 2-speed Slow Handpiece Will sell with or without various attachments Like new--Great Price(323)851-6622.

**DENTAL PRACTICE FOR SALE** IN ONTARIO Starter Practice on main street. Low Rent! 3 operatories. Call Loc Pham, Broker at LCF BRE#01875780. (714)550-7494 7494 or practice@lcfinc.com | LCFPracticeSales.com.

**WESTMINSTER/HUNTINGTON BEACH** TURNKEY OFFICE: 2 OPS, 1 X-ray room on busy strip mall, low rent, great starter office. 714-319-4956.

**Treatment Coordinators** needed for new Baldwin Park office. Full time + Benefits. Please send resume to dtresume@cdgdental.com.

**3 Self contained** suction units for sale very quiet white laminate cabinet great addition to office \$800each can install 714-650-1687.

**Exodontist Available** for Extractions in Your Office - Fluent Spanish, Will bring own instruments, Licensed CA dentist, Flexible schedule. LAOralSurgeonSpecialist@gmail.com.

**Dentist Needed** Riverside County busy practice. PT/FT. Minimum 2 years experience.Great staff/compensation.Please email CV h.pourshirazi@yahoo.com.

**Small papoose board** and PediWrap for sale. Olympic Medical. LA county. Email: sugarbug888@gmail.com. \$200.

**GP needed** for Pediatric dentistry in South Gate. Well trained, experienced staff in fun office setting. Send resumes to dtresume@cdgdental.com.

**Downtown Burbank** practice is entertaining applications for a DENTAL ASSISTANT position. Interested parties please call Dr. San Gabriel at 818-813-7572.

**FOR SALE** Mid-West Tradition F/O Small Head--Push Button Just overhauled 6-month warranty Like New Great Price (323) 851-6622.

**4 used** Belmont chairs w/ light and delivery system for sale in Irvine ca.call for more info:949-653-8888.

**%5 off all Osteogenics** Cytoplast and buy 5 get 1 free, www.dentalprodx.com

**CHAIR UPHOLSTERY** 15% OFF Expert Stitchwork. Fast Turnaround. Great Rates. Contact Us Today! 877-535-1733 / www.repairmakers.com.

**North County San Diego** 4 Ops. GP Practice w/ Prostho emphasis. 75% Fee For Service. Low Overhead. Nice looking office. Ken Rubin Practice Sales (619) 299-6161.

**Looking for an established** Orthodontist to join a state of the art multispecialty practice in Beverly Hills. Please contact dnaysan@gmail.com.

**They made the process** of building my office much easier. Made the stress of opening a new office much easier. Dr. R. Pullen. 714-240-7179 (All County).

**Do you have implant problems? Stripped or broken screws, loose abutments, failing or loose implants? I can help.** Call Dr. Alice Moran 949-361-4867.

**Buying A New Practice** Call Bob Affleck for your practice financing needs 949-939-4550.

**Brea GP** private practice is seeking associate part time leading to full time. Experience preferred. Email: brea5xteam@gmail.com.

# Don't See Your Ad?



Every week dozens of people place reader ads but forget to include a phone number or email address, others exceed the 20 word limit for free ads so we must delete them. This happens over 100 times a month! If you don't see your ad, this may be why. Be sure to include some form of contact info so our readers can respond and don't try to squeeze in extra words.

# If you have cell service...



...you have  
**The Dental Trader!**  
As mobile as you are.  
**dentaltrader.com**

**"Radius" Dental Operator** - Right and Left Use. American Manufactured, 10 Year Warranty \$5995 Delivered and Installed. Call (800) 423 - 5657 or visit [DHPDENTAL.COM](http://DHPDENTAL.COM) for more details.

**Marketing Marketer** needed to help start-up dental office. Need help introducing patients to our office in CARSON. Flexible hours [carsondentoffice@gmail.com](mailto:carsondentoffice@gmail.com).

**FOR SALE** Like-new Star 430 SWL F/O Newly refurbished Have 6 only. 6-month warranty Great selling price (323) 851-6622.

**Practice and Building Sale** San Diego County. General dental practice with \$375,000 collections in 2014 on 3 days/week. 5 operatories in a 2,200 sqft free-standing building. Street-corner location. Broker - Charles Kim 800-416-2055.

**Beautiful Encino** Boutique type office looking to share office 3 days a week, 5 ops. available. Call (818) 783-0491.

**Receptionists needed** for new Baldwin Park office. Full time + benefits. Please send resume to [dtresume@cdgdental.com](mailto:dtresume@cdgdental.com).

**Oxnard GP Practice** 4-sale. fee-4-service & PPO only. 4 ops. \$870K 2014. serious buyers only. [oxnardsmile@gmail.com](mailto:oxnardsmile@gmail.com).

**One man's treasure** is another's useless crap. Clean out that junk drawer and turn your unneeded items into CASH by advertising them in The Dental Trader FREE! Visit <http://thedentaltrader.com/faqs.htm> for instructions on placing a free ad today.

**FOR SALE** Zila pro-select platinum dental ultrasonic piezo scaler system. Used, in great working condition. \$1950, obo Contact: [dds714@yahoo.com](mailto:dds714@yahoo.com) 415-895-0477.

**WANT REAL ESTATE????** If so, contact DDS Xpress Realty. I can locate any property anywhere. BRE #01049085 Tina Ochoa, Realtor (951) 309-3196.

**LONG BEACH PRACTICE FOR SALE** Gorgeous, modern 5 operator private practice for sale - 78 year old owner retiring - 4 1/2 days of hygiene - digital x-rays - Grosses almost \$1.1 million/year - Thomas & Fees Practice Sales (714) 544-4341.

**A-DEC 511** Patient Chair & matching 611 Doctor's stool original cost \$12,000 Like New, Make Offer 855-772-7645 or [janetm@hygiacare.com](mailto:janetm@hygiacare.com).

**OWN YOUR REAL ESTATE** San Bernardino - 7 exam rooms. 3 suites. ID#CA76577. Call Maria at Practice Concepts 877-778-2020 x.108.

**Endodontists available** at your office. Efficient, experienced team. We will bring our own equipment, supplies, microscope and assistant. **NO INVESTMENT** needed on your part. [Smartendo1@gmail.com](mailto:Smartendo1@gmail.com).

**DENTAL PRACTICE AND REAL ESTATE FOR SALE** IN MORENO VALLEY. Freestanding Building on busy street. 2,500 sqft, 4 operatories + 1 plumbed. Call Loc Pham, Broker at LCF BRE#01875780. (714)550-7494 or [practice@lcfinc.com](mailto:practice@lcfinc.com) | [LCFPracticeSales.com](http://LCFPracticeSales.com).

**Intraoral Cameras** INVENTORY REDUCTION! Best Technical Support and Warranty. Use PROMO code TRADER on [www.Lensiora.com](http://www.Lensiora.com) for our clearance pricing!

**Lowest price ever** on Award Winning Digital Sensors. Sensors starting as low as \$3,999. Don't wait! This deal of a lifetime ends December 31, 2015. Call 1(800)397-6046.

**List your practice** with the professionals, don't leave thousands on the table, know how to maximize your value, call Henry Schein PPT - Steve Caudill 951- 314-5542.

**Glendale Practice for Sale (Confidential sale) Fee for service, 50+ years old, 3 ops, computerized, digital x-rays, 2014 collection \$305,000.00 from 3.0 day work week, Low overheads. Call 909 802 5000.**

**\$5495 New** Dental Operatory, Includes Free Dentists Stool, Delivery and Install. Made in USA 10 Year Warranty. Call (800) 423 - 5657 or visit [DHPDENTAL.COM](http://DHPDENTAL.COM) for more details.

**THOUSAND OAKS** Turnkey Office w charts for sale. Charts included but not guaranteed. (4) op comput G.P. (2) ops eqt'd/(2) add. plumbed. Located in a beautifully built out condo in a landmark prof. bldg. on a main thoroughfare. Newer Sirona eqt, Midmark cabinets, Dentrix s/w & digital x-rays. Seller moving, but will assist w a short transition. D&M Practice Sales 818.591.1401.

**State Of The Art New Practice Construction-Experienced Licensed Contractor! Will Beat Any Written Estimate By 10%! Email [Practicecoaching@gmail.com](mailto:Practicecoaching@gmail.com). Call 213-256-1150.**

**Attend 6 top-notch** courses (5 Lecture & a Hands-on Oral Surgery course, 42 CA & AGD CEs) for only \$599, all on Sundays, in a convenient OC location! Visit [www.xcelseminars.com](http://www.xcelseminars.com) for info.

**PRACTICE FOR SALE ANAHEIM** GP w/ 24 yrs gdwill; Proj approx. \$527K for 2015. California Practice Sales, Inc. Phone: 714-639-2775.

**FRESNO** General Dental Practice & Building FOR SALE contact Brooke at 714-259-0501 for more details.

**PRACTICE FOR SALE RANCHO MIRAGE.** Estab GP in Busy, Upscale retail center. 4 Ops in 1500 sq.ft. LOTS referred Out!! SDPS: 769-599-7828.

**DENTAL PRACTICE FOR SALE DIAMOND BAR:** Shopping Center. Super Look 4 Ops. Retiree. Big upside. Call Broker - Practice Sales & Appraisals (818) 999-9595.

**Santa Barbara** general practice collects \$772,000 per year consistently with a net income of \$225,000 on less than 4 days per week. 4 ½ days of hygiene/week. 4 ops. Asking \$650,000. Kurt Skarin 805-777-7707.

**Hands On bone Grafting** Course with live "All on Four" surgery presented by Bone bank and Dr Navid Senehi, Oral Surgeon- Woodland Hills. CE Credits + Lunch included. contact John [john@fosinstitute.com](mailto:john@fosinstitute.com) / Cel 818-359-9715.

**Sellers needed** in the San Fernando Valley, West LA, Riverside Area; I have your qualified buyer. Greg Beamer 909-542-4891.

**Bone Graft** and Membrane prices at the lowest you have ever seen advertised. Bone Bank is one of the very few actual FDA approved mfg's of regenerative products in the US. \$35.00 Per CC vial of, Mineralized or demineralized human bone. Contact [Elke@SynergySpecialists.com](mailto:Elke@SynergySpecialists.com). 323-828-9362.

**VANDENBERG AIR FORCE BASE** Lompoc - 5 exam rooms. ID#CA76584. Call Maria at Practice Concepts 877-778-2020 x. 108.

**COLTON** 3 large ops. (almost 10'x10') with digital x-ray, dual sinks and cabinetry in each op. Going digital. 1200 sq. ft. Gross \$\$ up 39% this year! [iepracticesales.com](http://iepracticesales.com) (951) 816-6242.

**Roving ENDODONTIST** Needed. SAN DIEGO County - multiple offices. Excellent Compensation. Call 619-342-6070.

**Periodontic Practice** Well established with large referral base, nicely appointed office. More details provided upon request. Ken Rubin Practice Sales (619) 299-6161.

**ROSEVILLE** New listing. Call today for more information! [IntegrityPracticeSales.com](http://IntegrityPracticeSales.com), Broker Bill Kimball, DDS, BRE #01911548. (855) 337-4337.

"Dear Pat, I truly appreciate all the hard work and thoughtfulness you put into this whole endless ordeal. Your calm manner during my highly stressful process was invaluable. I am grateful for your tireless persistence. You are now part of my dream team. Take good Care" LYNN LEMPERT, DDS Beverly Hills, California. CALL TODAY 800-499-1474 WOOD & DELGADO [www.dentalattorneys.com](http://www.dentalattorneys.com).

**Cecilia Chen, Esq.** always made herself available to answer our questions, many times getting back to us in the middle of the night to make sure everything was addressed. -Rita and Frank Woo, DDS. Call us for a complimentary consult. Toll Free: 855-850-4111, [Cecilia@practiceatty.com](mailto:Cecilia@practiceatty.com) or [www.practiceatty.com](http://www.practiceatty.com).

**CLARIS i4D** IntraOral Camera. The ultimate everyday IntraOral camera. Sony CCD sensor. Clearer Image. Expertly engineered. 2 year warranty. Brand new. List: \$3,995. Sale: \$2,750. Call 310-204-6134 and ask for Mark.

**FREE ONLINE CLOUD BACKUP** up to 2GB. HIPAA Compliant with full data encryption. See [www.ez2000dental.com](http://www.ez2000dental.com), then click Products Link, then click Cloud Backup Services, and Download the FREE LINK. Need help? Call 800-273-5033. No charge for our assistance.

**Financing for your practice** and so much more. We can help you reach your practice goals. Call Wells Fargo Practice Finance at 1-888-937-2321 or visit us at [wellsfargo.com/dentaltrader](http://wellsfargo.com/dentaltrader).

**AEU-7000** E70V, Aseptico + 2 hand pieces, like new. For \$4000. Call. 562-692-7870.



# Buying? Partnering? Selling?

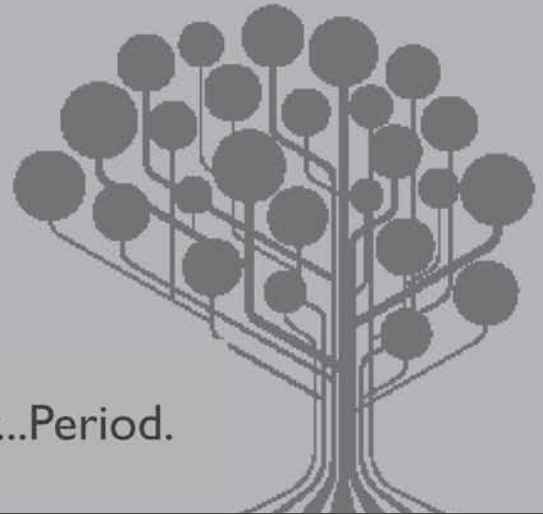

Find out what Better really means..  
Better Rates. Better Service. Just Better...Period.

**PRACTICES FOR SALE • BUYER SERVICES • APPRAISALS • PARTNER BUY-INS**

“Your expertise, knowledge and help (in practice sales) far exceeded my expectations... I felt like a VIP receiving special service and advice.” – Dr. Dery (seller). **BUYING or SELLING a Practice?** Call Practice Concepts. Over 20 years of experience. Better Service. Better Rates. Just Better. Call Maria Silva or Scott Daniels at 877-778-2020.

**OWN YOUR REAL ESTATE:** San Bernardino – 7 exam rooms. 3 suites. ID#CA76577

**MULTI-SPECIALTY:** Santa Ana – 8 exam rooms. Collections over \$750,000. ID#CA76585

**WINE - N - DINE AFTER A LONG DAY AT WORK:** Temecula – GP w/ one large exam room. ID#CA76595

**DENTISTRY SUNRISE TO SUNSET:** Huntington Beach – 4 exam rooms. Real estate available. ID#CA76586

**SPANISH VILLAGE BY THE SEA:** San Clemente – 4 exam rooms. Leaseholds & equipment. ID#CA76594

**THE WEST’S BEST BBQ:** Santa Maria – 4 exam rooms. ID#CA76583

**VANDENBERG AIR FORCE BASE:** Lompoc – 5 exam rooms. ID#CA76584

**SMILE YOU’RE ON CANDID CAMERA:** Los Angeles – GP for sale. Near Paramount studios. \$350K gross. Large office w/ 4 exams. ID#CA76578

**COMING SOON:** Practices for sale in Orange, Lake Forest, Oceanside, and West Covina



Maria Silva, Agent

Practice Concepts  
Welcomes  
Maria Silva to our team

Call Us at 877-778-2020



Scott Daniels, Broker



**Call 877-778-2020 for a FREE & Confidential Market Evaluation!**  
**For more listings and information, go to: PracticeConcepts.com**

**ZOOM Light** 3rd generation. Excellent condition, 12 hours. \$125.00. 559-435-3111.

**Dental Assistant** F/T, P/T. needed in La Mirada. Please fax 562-777-7077 or e-mail [globaldentistry@yahoo.com](mailto:globaldentistry@yahoo.com).

**Well slap my butt** and call me Spanky...I can subscribe, change my address or cancel my free Dental Trader subscription anytime at <http://www.thedentaltrader.com>.

**Oral Surgeon** needed part time or full. Northern California. Great opportunity, new office. Call for details 530-223-6000.

**RDA COURSES** Coronal Polishing, Radiation Safety, Infection Control, BLS/CPR. CEUs \$19 Online: 2 Hr Infection Control, Dental Practice Act.(888) 988-2364 [www.ADMIInstitute.com](http://www.ADMIInstitute.com) [info@adminstitute.com](mailto:info@adminstitute.com).

**Thank you for helping me** with my insurance needs. I appreciate your professionalism in getting this done quickly! – Yaron Miller DDS, San Diego. [www.TheDoctorsInsuranceBroker.com](http://www.TheDoctorsInsuranceBroker.com).

**If delivering a better** dental experience for your patients is your goal, upgrading or expanding your practice is one of the best investments you can make. Call Wells Fargo Practice Finance at 1-888-937-2321.

**Thank you for helping me** with all my insurance needs. I appreciate your time and professionalism in getting this done quickly! – Yaron Miller DDS, San Diego. [www.TheDoctorsInsuranceBroker.com](http://www.TheDoctorsInsuranceBroker.com), [jonathan@tdibroker.com](mailto:jonathan@tdibroker.com) or call 800-767-0864.

**Free Retirement Plan** Feasibility Study with every incorporation. Attorney Robert W. Olson, Jr., 805.963.1120, [www.transdental.com](http://www.transdental.com).

**Purchasing your first practice?** Bob Affleck at Citi Practice Finance he will guide you through the process 949-939-4550.

**DENTAL HANDPIECE REPAIR** 50% OFF New Customers Only. Premium Parts Standard. Contact Us Today! 877-535-1733 / [www.repairmakers.com](http://www.repairmakers.com).

**PRACTICE SALE** SANTA MONICA. Retirement sale. Established general dental practice. \$400,000/yr collections. PPO/FFS. 4 operatories. Upscale building, top floor, panoramic views. Broker - Charles Kim 800-416-2055..

**Lowest prices** on Regenerative Products- Buy 3 get 1 on all Miltex Collagen Products! 15 x 20mm Helimends @66.00 [www.dentalprodx.com](http://www.dentalprodx.com).

**RDAs needed** for new Baldwin Park office. Full time + benefits. Send resume to [dtresume@cdgdental.com](mailto:dtresume@cdgdental.com).

**Whether you need help** funding a ground up construction project, purchasing commercial property, refinancing or consolidating existing loans or acquiring a practice, Live Oak Bank can help. 877.890.5867 [www.liveoakbank.com/healthcare](http://www.liveoakbank.com/healthcare).

**Perfect Apical Seal** With Life Time Warranty For ALL Inoperable Endo. I Provide Everything. visit: [www.socalrootcanal.com](http://www.socalrootcanal.com).

**"Last minute review** of Buy-Sell Agreement. Call today for fixed pricing!" Law Offices of Amy L. Borden, Esq. (888)416-1321. [www.californiadentalattorney.com](http://www.californiadentalattorney.com).

**Encino practice 3 ops, nice view, great opportunity for starting, moving your existing office, or specialist. Motivated seller. Email generation2100@aol.com.**

**Attend 5 top-notch lectures** (35 CA & AGD CEs) for only \$475, all on Sundays, in a convenient OC location! Visit [www.xcelseminars.com](http://www.xcelseminars.com) for info.

**Speak with an experienced** dental attorney today about practice transition legal pitfalls. Levi Barlavi. (888) 776-5384 [www.dental-attorney.com](http://www.dental-attorney.com).

**Professional Services** Need a local bank that can meet your closing date and **FUND YOUR LOAN FAST?** Call Sunwest Bank 714-730-4412.

**ORAL SURGERY IN YOUR OFFICE** (SD/OC/LA areas). Stop referring out. Friendly, experienced Oral Surgeon (DDS, MD) will perform your surgical procedures in your office. Wisdom teeth, implants, sinus lifts/grafting. IV sedation. Will bring assistant, implants, all necessary instruments and equipment. Great with patients. References available. Flexible hours. Please email with any questions. [SDOralSurgery@yahoo.com](mailto:SDOralSurgery@yahoo.com).

**Luis Kong, DDS** (San Francisco, CA)- Thank you Dr. Chester Jeng of Law Offices of Jeng and Associates. Your prompt attention to my concerns is something I am so thankful for. Definitely, you are the "go to" attorney for me. Call Jeng & Associates 714-858-0536.

**All County Construction** High Quality and Great Service within YOUR Budget! Specializing in Dental / Medical Construction since 1991. (714) 240-7179.

**Don't sign that lease!** The new trend in commercial property lease agreements is to include terms that are so one-sided, you lean when you read em! Get an expert review BEFORE SIGNING. Call Kerendian & Associates 888-299-7848.

**FAST, PERSONAL, LOCAL** COMPETITIVE FINANCING...At Orange County Business Bank you aren't just a loan. You'll get your financing done fast, without the red tape of bigger banks! Contact Howard Boles 949-379-5704. Equal Housing Lender-The bank makes such loans without regard to race, color, religion, national origin, sex, marital status, age, handicap, familial status, applicant's receipt of income from any public assistance and applicant's exercise, in good faith, or any right under the Consumer Credit Protection Act. Member FDIC.

**Oral Surgeon** or Exodontist to work in Oxnard. High volume office. Please send your resume to [faframiyan@hotmail.com](mailto:faframiyan@hotmail.com).

**looking for PERIODONTIST** to join a fast growing surgical group in all California .please send your resume [info@drmalboubi.com](mailto:info@drmalboubi.com) 9492000600 5105160027.

# DENTAL DIRECTORY

## REPAIRMAKERS

DENTAL EQUIPMENT REPAIR PROS

Call For Great Offers 877-535-1733  
www.repairmakers.com



## PROFESSIONAL PRACTICE LENDING PROGRAM

- Practice Acquisitions
- Partnership Buy-ins and Buy-outs
- Refinance and Debt Consolidation
- Expansion and Relocation
- Equipment Purchases



Call Howard Boles  
(949) 379-5704



hboles@ocbusinessbank.com



Orange County  
BUSINESS BANK

## GET ON BOARD!!

Make an easy ride for yourself!  
Let your ads do the work!



www.dentaltrader.com



Your voice for excellence  
through education and advocacy

The only organization dedicated to the needs of the general dentist.  
Learn more about everything that AGD has to offer by visiting

www.agd.org and

Join Today!

Call toll-free at 888.AGD.DENT (888.243.3368)

## ROBERT W. OLSON, JR.

a Professional Corporation  
Business, Corporate & Real Estate Law

- USC Law 1984, Dartmouth 1981
- All Inclusive Packages
- Free Website Services

888.963.1120

www.transdental.com  
RWO@transdental.com



## Alex Hornaman General Flooring

- All types of Unique Wood Flooring
- Installation with designs, patterns, inlays
- Base/Case/Crown Molding Installation. Since 1996

Alex Hornaman  
Call 714.390.3250  
Fax: 714.841.0496

Licensed & bonded #801982

## Practice Financing

WELLS  
FARGO

Call us for a complimentary consultation today.

Sina Mansouri 1-855-544-0245    Jason Schneller 1-888-220-7321    Kris Nishihira 1-855-405-2107

Or visit us at [wellsfargo.com/dentaltrader](http://wellsfargo.com/dentaltrader).



## Tired of Paying Your Silent Partner 50%?

Keep more \$\$\$ by lowering your tax bite

Can your tax preparer answer these questions:

- How can I deduct \$734 per day for business travel?
- How can I write-off 25% of my home expenses as business-related expenses?
- How do I deduct 100% of the cost of a home repair?
- How do I deduct \$50,000 for the cost of my vehicle?
- What items in my building can be expensed over 5 years?



Raymond Furness, CPA, M.S. Tax

Tel: 818.990.0686 | [www.FurnessCPA.com](http://www.FurnessCPA.com) | [Raymond@FurnessCPA.com](mailto:Raymond@FurnessCPA.com)



wlads@pacbell.net • westernlads.org  
14722 Hawthorne Blvd. Ste B  
Lawndale, CA 90260-1505  
310-349-2199

# DENTAL DIRECTORY



## CALIFORNIA PRACTICE SALES INC.



**John W. Knipf**  
President

**Robert A. Palumbo**  
Executive Vice President

326 W. Katella Ave. #4-G, Orange, Ca 92867  
(714) 639-2775 • [www.calpracticesales.com](http://www.calpracticesales.com)

CA DRE #00491323

Rope in Profits!



[www.DentalTrader.com](http://www.DentalTrader.com)

## THE #1 DENTAL LAW FIRM IN THE NATION



WOOD AND DELGADO

- Legal Advisors to over 15 Dental Societies
- The Chosen experts on Business Transactions for Dentaltown
- 180+ Dental Practice Transitions in 2014
- Providing service to clients NATIONWIDE



Patrick J. Wood,  
Jason P. Wood  
& Marc Effinger  
Attorneys at Law

800-499-1474  
[www.DentalAttorneys.com](http://www.DentalAttorneys.com)



PRACTICE SALES AND LEASING  
"THE PERSONALIZED SERVICE DENTAL BROKER"®



Paul Maimone  
Broker/Owner

P.O. Box #6681, Woodland Hills, CA 91365  
Phone: 818.591.1401 • 866.425.1877 Outside So. CA  
[www.dmpractice.com](http://www.dmpractice.com)

CA Broker Lic. #01172430



## Thomas & Fees

Practice Sales  
"A better kind of practice sales company"

**Philip L. Kempler, DMD, Broker**

Days: 714-544-4341 • Eve: 949-362-4749 • Fax: 714-731-7296

E-mail: [Phildr@cox.net](mailto:Phildr@cox.net)

## TAX • FINANCIAL ADVISORY • VALUATION

CUONG LE, CPA



2020 Pico Blvd., Suite C  
Santa Monica, CA 90405

(310) 450-5708  
[info@lecpa1.com](mailto:info@lecpa1.com)

Success Through Diligence

Commercial Bank



### Citi Healthcare Practice Finance

- Practice Acquisitions
- Partnership Buy-ins/Buy-outs
- Practice Loan/Debt Consolidation
- Expansion/Remodel/Relocation



Call Bob Affleck | 949-939-4550 | [bob.affleck@citi.com](mailto:bob.affleck@citi.com)  
Checkout our ad/read what your colleagues say about us



Ken Rubin & Company, Dental CPA's  
**Ken Rubin Practice Sales**  
**619.299.6161**

[www.kenrubincpa.com](http://www.kenrubincpa.com)  
[www.krpracticesales.com](http://www.krpracticesales.com)



## San Diego Practice Sales

- represents Sellers and Buyers
- exclusively in San Diego County
- more than 28 years of experience with the San Diego Dental Community

For More Information Call:

**(760) 599-7828**

[WWW.SDPRACTICESALES.COM](http://WWW.SDPRACTICESALES.COM)

Your ad here at a bargain price!!  
[www.dentaltrader.com](http://www.dentaltrader.com)



# DENTAL DIRECTORY



## PRACTICE SALES & APPRAISALS

*Reliability & High Ethical Standards  
You Can Trust - Proven Results  
You Can Count On*

Lou Bermudez, Broker or  
Frederic Sherman, DDS, Broker  
(714) 999-9595 • (818) 999-9595 (main office) • Fax: (818) 999-9615



*HOWDY PARTNER!*

**Contact us to promote your business here!**  
[www.DentalTrader.com](http://www.DentalTrader.com)



Go for the best - Get the *Highest Rated Software* by the ADA\*

**800-273-5033**

Online demo - [www.ez2000software.com](http://www.ez2000software.com)

**GB GREG BEAMER**  
DENTAL BROKER



The Name You Know  
The Reputation You Trust

(909) 542-4891 phone  
(866) 890-1033 fax  
DRE License # 01149524  
[info@gregbeamer.com](mailto:info@gregbeamer.com)  
[www.gregbeamer.com](http://www.gregbeamer.com)

**HENRY SCHEIN®**  
PROFESSIONAL PRACTICE TRANSITIONS

No. CA: 1.800.519.3458 • So. CA: 1.888.685.8100

[ppt@henryschein.com](mailto:ppt@henryschein.com)

[www.henryscheinppt.com](http://www.henryscheinppt.com)



**LCF**  
FINANCIAL  
SERVICES

Healthcare Financing & Consulting

**\*Low rates**  
for qualified borrowers

**(714) 550-7494 • [www.lcffin.com](http://www.lcffin.com)**

A Division of LCF Financial, Inc. \*OAC

## KINGS TWO DENTAL SUPPLY

*Your One Stop Dental Shop*

- Large Equipment
- Small Equipment
- Service Department
- Dental Supplies
- Ortho Products
- Digital Imaging
- Implantology
- Handpiece Repair
- Full Service Dental Lab

Tel: 800.715.5464

Fax: 626.581.8137

## Full Service Collections

**We feature:**

- Commission Fee Only
- Free Credit Bureau Reporting
- Spanish Speaking Collectors
- Full skip tracing & legal department
- Comprehensive month end and on demand reports
- Friendly experienced staff

**DCC, Inc.**

269 S. Beverly Dr., Suite 439  
Beverly Hills, CA 90212

**Direct Credit  
Control, Inc.**

Dental Collection Specialists

**888-860-2950**

[www.DirectCreditControl.com](http://www.DirectCreditControl.com)

**LEE SKARIN  
AND ASSOCIATES, INC.**

**KURT SKARIN**

DENTAL PRACTICE SALES & APPRAISALS

530 W. Stafford Road, Westlake Village, CA 91361  
805.777.7707 • 800.752.7461 • Fax: 805.777.0051

Email: [lsainc@aol.com](mailto:lsainc@aol.com)

[www.leeskarinandassociates.com](http://www.leeskarinandassociates.com)



CA DRE: 00863149

**ALL  
COUNTY  
CONSTRUCTION**  
Dental Office Design

**DESIGN/BUILD**

**T.I.'s • Remodels • Expansions • Free Standing Buildings  
Turn-Key Packages • Consultation**

**562-989-3350**

Free Estimates

**888-302-6111**

Lic. #669244



**General dentist** needed for South Texas practice, 250K+ earning potential, new grad/H1-B ok. contact: jmeski@gmail.com.

**NEW LED** Chair Mounted Dental Light - \$1595, Year End Discount \$600, now only \$995. Call (800) 423 - 5657 or visit DHPDENTAL.COM for more details.

**seeking experienced** RDH with great customer service, energetic and bilingual/spanish. part time position available. email your resume to: mrs.sandoval86@gmail.com.

**Dental Assistants** needed in Whittier for high volume children's dentistry. Full time + benefits. Send resume to dtresume@cdgdental.com.

**HU-FRIEDY INSTRUMENTS** Gracey (11/12)(13/14), Scaler (H5/U15), Explorer, Columbia, Barnhart, Morse. Like New, Make Offer 855-772-7645 janetm@hygiacare.com.

**GENERAL DENTIST NEEDED** FOR OUR PRIVATE OFFICE IN SAN LUIS OBISPO COUNTY. EXPERIENCE DENTIST SEEKING PART TIME POSITION (3 DAYS A WEEK) WITH THE OPPORTUNITY TO BUY OUT. FORWARD RESUME CDKRILLDDS@ATT.NET, BY FAX AT 805-239-9097 OR CALL FOR AN INTERVIEW 805-801-2654.

**I am a Highly experienced** and efficient GP seeking PT position I will do all phases including RCT please email caring dds@aol.com.

**Dental marketing/PR** person needed in Los Angeles, great compensation, FT, call for immediate position (310) 384-4360.

**Dental Assistants** needed for new Baldwin Park office. Full time + benefits. Send resume to dtresume@cdgdental.com.

**SALE ANAHEIM** REVENUE \$800k+ last 10years. 7ops, HMO/PPO/PVT. Newer equip. Email: socialteeth@gmail.com No brokers please.

**DENTAL FRONT DESK** 2yrs Experience, SOFTDENT, Insurances, ENGLISH-SPANISH, Position-immediate, TERMINOLOGY, Full-time, CDA, Compensation-experience, CHULA-VISTA, Colmillo58@aol.com.

**WaveOne** Files By Dentsply All Sizes Pack of 3Files \$55. Free S&H. eismaildds@yahoo.com.

# GET MORE!



The Dental Trader publishes far more ads placed by California dentists and their staff than any other dental publication in the country.

"Nothing says readership like participation of readers!"

**Place your free ad today!**

## CHANGE OF ADDRESS FORM

**THE Dental Trader**  
*Buy, Sell or Trade all things Dental*

### OLD ADDRESS

Dentist's Name \_\_\_\_\_  
Address \_\_\_\_\_  
City/State/Zip \_\_\_\_\_

### NEW ADDRESS

Dentist's Name \_\_\_\_\_  
Calif. Dental License # \_\_\_\_\_  
Address \_\_\_\_\_  
City/State/Zip \_\_\_\_\_  
Phone \_\_\_\_\_ Fax \_\_\_\_\_  
E-mail \_\_\_\_\_  
Authorizing signature \_\_\_\_\_

**PLEASE MAIL TO:**  
PO Box 2631, Capistrano Beach, CA 92624  
or Fax this form to 949.498.1198  
on or before the 1st of the month.  
For faster filing, submit this form online at:  
**www.dentaltrader.com**

**2 new endo** reciprocating handpieces by W&H for standard hand files includes factory e-type motor \$1100ea 818 522-1745 hksr9tc@gmail.com.

**TOUCH N HEAT** SYBRON ENDO BUCHANAN HEAT PLUGGER TIPS DIFF SIZES ALL NEW U.S. MADE. \$89. PayPal eismaildds@yahoo.com.

**I am interested** to buy (ScanX USB inline eraser for panoramic and cephalometric plates) in good working condition 818 383 5797.

**RDAs needed** in Whittier for high volume children's dentistry. Full time + benefits. Send resume to dtresume@cdgdental.com..

**Board-Certified** Periodontist Available. Los Angeles, Orange County, San Diego. Flap Surgeries, Bone/Soft Tissue Grafts, Sinus, Implants, Extractions. doperiodontics@gmail.com 3238253490.

**For Sale Adec** unit light \$875.00 Belmont intra-oral X-ray machine \$895.00 Email: pacificdental65@gmail.com.

**BEAUTIFUL 3 OP ALL DIGITAL TURN KEY PRACTICE AVAILABLE FOR SUBLEASE/SALE IN HEART OF WEST LA. PERFECT FOR SPECIALTY OR NEW GRADS W MINIMAL INVESTMENT. ASKING 75,000 OBO, CONTACT DENTAL404@YAHOO.COM.**

Copyright 2015 THE DENTAL TRADER. All rights reserved. No part of this publication may be reproduced or transmitted in any form or by any means, electronic or mechanical, including photocopy, recording, or any storage of information and retrieval system.

# Reach every dentist in California!

***Submit your reader ad online!***

***See FAQs page at [dentaltrader.com](http://dentaltrader.com) for instructions***

**Your ads post instantly to Ad Board!**

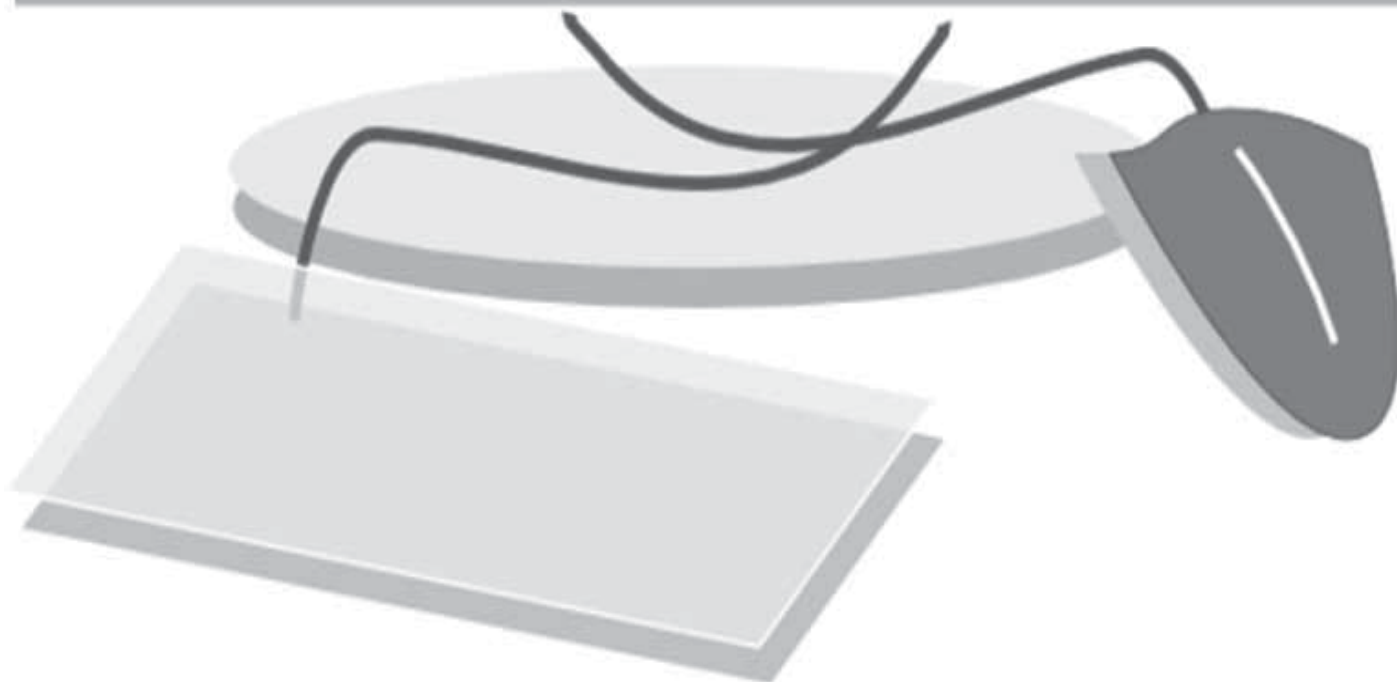

**dentaltrader.com**

# SAN FERNANDO VALLEY G.P. OFFICE FOR SALE



PICTURES ARE REPRESENTATIVE

- (8) Op fully equipped G.P. with central nitrous
- Located in a multi story high rise prof. bldg. on a main thoroughfare
- Cash/Ins/PPO/HMO Patient Base w approx. \$7K/mos Capitation Checks
- Computerized Office (Dentrix G5) & Digital X-Rays & CT Scan
- 2014 Gross Collect. of \$1.33M+. 2015 Projected Collect. of \$1.4M
- Open (5) days/week with no nights & no weekends
- Averaging 50+ new patients/mos. with (5) Hygiene days/wk
- 40+ Years of Goodwill



CA Representative for The National Association of Practice Brokers (NAPB)

**Call Today**

*Trust your Practice Purchase or Sale to  
The Personalized Service Dental Broker®*



**For all your Practice Transition Needs!**

**818.591.1401** or  
**866.425.1877**  
(Outside So. CA)

**www.dmpractice.com**

P.O. Box 6681, Woodland Hills, CA 91365

CA Broker License #01172430

# Flat Rates – Zero Problems

*“Bob completed our incorporations and partnership agreement, Kevin’s original buy-in, and now our partnership dissolution and Larry’s buy-out. At each stage, Bob thoroughly and clearly documented each transaction, was quick to respond to our questions, and completed each at a flat rate with zero problems. We would recommend him in a heartbeat.”*

Larry Basham, DDS, and Kevin Miller, DDS.

---

## Robert W. Olson, Jr., APC

Dental Practice Sales & Purchases  
Partnerships, Property Purchases & Leases  
Corporations & Audit Protection

**888.963.1120**

RWO@transdental.com  
www.transdental.com

**#1 Avvo® Rated  
Attorney in USA  
2011 to Present:**

**Mergers & Acquisitions  
Incorporations**