

THE Dental Trader

VOL. 12 NO. 12 • DECEMBER '15
No. Calif. Edition

Ph: 877-888-4237 • 949-429-6836
Fax: 949-498-1198 • DentalTrader.com

FREE ADS FOR DENTISTS
& STAFF!

Buy, Sell or Trade all things Dental



EZ 2000 DIGITAL
DENTAL SYSTEM

Digital Dental X-Ray System Half-Price Special

DIGITAL SYSTEM INCLUDES:

Everything you need for a Digital Exam Room!

Hi-Quality Diagnostic Digital X-Ray Sensor & Intra-Oral Camera, Dell i5 Computer & 22" Monitor with 3 Year Onsite Warranty, External Backup Drive, Surge Protector, Mobile Cart (Pole or Rectangular), EZ 2000 Plus Advanced Practice Management Software & Integrated Imaging Software (or keep your own billing software & we provide bridge for free), Full Blown Color Coded Scheduler, Graphic 3D Movable Tooth Charting, Timeclock, Installation, Onsite Training & Technical Support.

\$9,995

Regular Price: \$19,990

Or Lease to Buy:

- No Money Down
- No Payments for 90 Days
- \$220 per mo. for 60 mos.
- \$1.00 Buyout

Free Apple Watch
with purchase



Perfect for the dentist - glance at your notifications without touching anything, and keep your phone in your pocket so that you can keep working on your patient.

Video Demo @
www.ez2000digital.com

BBB
A+ Rated



"Schedule your
FREE In-Office
DEMO Today!"



Call for your **FREE**
in-office Demo:
800-273-5033

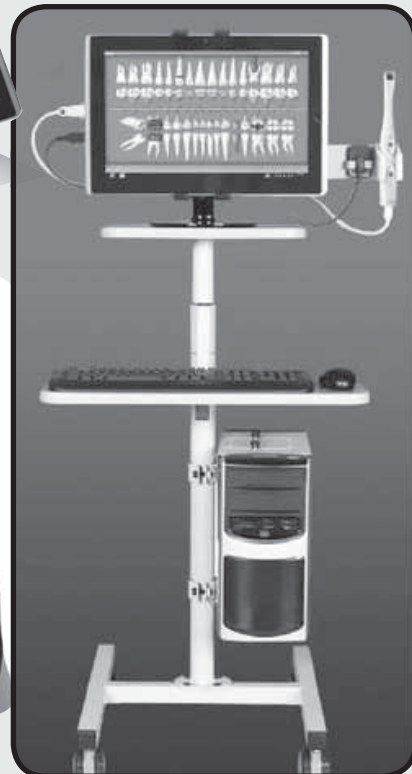

The Most Advanced Digital Dental Office Solution on the Market Today

- Sharpest Image Quality Digital Sensor
- Graphic Tooth Charting with 3D Movable Teeth
- Text Messaging and Emailing, Medical Cross-Coding
- Patient Kiosk Entry, Mobile App, Signature Pad
- Optional Integrated Benefit Service by Trojan Prof. Services, as well as Credit Card Processing & Electronic claims

We bridge to virtually all practice management systems

HOW DOES YOUR PRACTICE TRANSACTION ATTORNEY STACK UP?...



**PATRICK J. WOOD,
JASON P. WOOD &
MARC ETTINGER**

ATTORNEYS AT LAW

- Legal Advisors to over 15 Dental Societies
- The Chosen experts on Business Transactions for Dentaltown
- 180+ Dental Practice Transitions in 2014
- Providing service to clients NATIONWIDE

"As frustrating as this whole situation was, I don't feel like I missed out on anything. Everything about this deal was sketchy from beginning to end. However, I wanted to thank you for all of your help because you constantly helped me from making irrational decisions out of fear and impatience."

NANCY NGUYEN, DDS
New York, New York

Call today for a free phone consultation



800-499-1474



www.DentalAttorneys.com

Specializing in

Practice Acquisitions/Sales, Partnerships, Business Transactions, Lease Negotiations, Estate Planning, Transitions & Business Litigation

Wells Fargo Practice Finance

WELLS
FARGO

We're here to help you every step of the way



Thinking about purchasing or starting a practice? Let's talk.

Call us for a complimentary consultation.

Andrew Ventura

East Bay, Northern California • 1-855-853-4751

Brandon Finazzo

San Francisco Bay Area • 1-888-874-1590

Or visit us at wellsfargo.com/dentaltrader.

ADA Business ResourcesSM

Wells Fargo Practice Finance is the only practice lender selected especially for ADA[®] members and endorsed by ADA Business ResourcesSM.

All financing is subject to credit approval.

ADA[®] is a registered trademark of the American Dental Association. ADA Business ResourcesSM is a service mark of the American Dental Association. ADA Business Resources is a program brought to you by ADA Business Enterprises, Inc., a wholly owned subsidiary of the American Dental Association.

© 2015 Wells Fargo Bank, N.A. All rights reserved. Wells Fargo Practice Finance is a division of Wells Fargo Bank, N.A. ECG-1706203

Together we'll go far



We have 3 peri-apical dental x-ray for sale we no longer use please call 209-322-3429.

dental compressor not working \$250.00 OBO (949)661-6255.

PLACE A FREE AD TODAY! See FAQs page at dentaltrader.com.

Advanced Zoom Whitening lamp for sale. Works like new. \$550 OBO 310-994-5336.

GP Implant Office For sale located in San Francisco Bay Area Retiring Owner Cell: 925-864-3713.

Experienced DDS looking to purchase practice in the greater Sacramento area. Please call 760 261-1757.

DENTIST needed pt for office in san jose, 3 years min exp, please call 818-203-4272.

For Sale SOREDEX Digora Optime Dental X-Ray Machine. 760-434-5066 San Diego.

Looking for used Secondhand Gendex 765DC Sensor #1. 818-716-0297.

WaveOne Files By Dentsply All Sizes Pack of 3Files \$55. Free S&H eismaildds@yahoo.com.

WHY A DENTAL CPA? Call 714-259-0505 Wiederman & Chamberlain, CPA.

DUST COLLECTOR 60U By Handler Mfg. Never Used. \$550. OBO. 949-202-4420.

STOCKTON Too good to be true? Absolutely not! 1,600 sf w/ 3 ops. \$95k (IN-474) WPS/800-641-4179.

Looking for a dental office preferably seller retiring/ in transition, Immediate available to work as an associate. contact 7142997653.

Mobile Dental Truck for sale Van and a Trailer with 2 dental chairs, email mobiledental@mail.com for details.

Orville General Practice 5 Ops. 2,500 sq ft. Digital X-Rays. Gross Production 2014 \$316K on 3 days. kearbeyve@gmail.com.

Encino A private practice for sell, 4 Ops, all digital, CT scan, Laser, CEREC. 8182358650.

General Dentist needed 2 to 3 days a week. Please call 925-550-2696 or fax resume 209-463-1432.

Dental chair Royal Model 17. Great condition. Photos on request. Make reasonable offer. Paul. paulkratzer@yahoo.com. 323-528-1442.

Happy Holidays!



PRACTICE SALES AND LEASING



Paul Maimone Broker/Owner
CA Broker #01172430

CA REPRESENTATIVE FOR THE NATIONAL
ASSOCIATION OF PRACTICE BROKERS (NAPB)

KERN COUNTY

BAKERSFIELD #29 - PRICE REDUCTION! (4) op comput. G.P. (3) ops eqt'd, (4th) plumbed. Located in a free stand bldg. Cash/Ins/PPO/HMO pts. Digital x-rays. Annual Gross Collect \$300K+ on a part time schedule. Seller is moving and is motivated.

BAKERSFIELD #31 - (4) op computerized G.P. & free standing Duplex Building for sale with excellent signage & visibility. (3) ops eqt'd / (4th) plumbed. Cash/Ins/PPO pt base. No HMO & no Denti-Cal. (46) years of Goodwill. Annual Gross Collections approx \$350K. Office does no advertising. Refers out all Ortho, Perio Surgery, Implant Placement, complicated Endo, & complicated O.S. **[NEW]**

So. KERN COUNTY - PRICE REDUCTION! (6) op comput. G.P. located in a Bakersfield suburb in a small strip ctr. with exposure/visibility. Pano eqt'd. Limited competition. Cash/Ins/PPO/HMO Denti-Cal pts. Annual Gross Collect. approx \$350K part time. Seller is moving and is motivated.

LOS ANGELES COUNTY

ARCADIA - (4) op computerized G.P. located in a well known Prof. Bldg. on a main thoroughfare. Cash/Ins/PPO pts. Annual Gross Collect \$300K+ on a (3) day week.

MONTEBELLO - (4) op comput. G.P. (2) ops eqt'd/(1) add. plmbd & (1) add. unplmbd. Located in a large busy shopping center w excell. exposure/visibility/signage & parking. Annual Gross Collect \$200K on a (2.5) day/wk p.t. schedule. Cash/Ins/PPO pt base w no HMO's or Denti-Cal. Office receives many walk-in patients. Very low overhead. Seller does no advertising. Seller is retiring but will assist w a Transition. **[NEW]**

MONTEREY PARK - PRICE REDUCTION! (6) op fully equipped computerized G.P. Located in a store front on a main thoroughfare with exposure, visibility & signage. Digital x-rays. Annual Gross Collections \$250K+ on a part time schedule. Cash/Ins/PPO pts. Seller is retiring but will assist with the transition.

SAN FERNANDO VALLEY - (8) Op fully equipped computerized G.P. with central nitrous. Located in a multi story high rise professional building on a main thoroughfare. Cash/Ins/PPO/HMO Patient Base with approx. \$7K/mos Cap Cks. Dentrax (G5), Digital X-Rays & CT Scan. 2014 Gross Collections of \$1.33M+. 2015 Projected Gross Collections of \$1.4M. Open (5) days/week with no nights & no weekends. Averaging 50+ new patients/mos. (5) Hygiene days/wk & (7) DDS days/wk. Refers out Ortho, some Endo & some Perio surgery. 40+ Years of Goodwill. See full page ad for this opportunity on page 71 of this issue. **[NEW]**

SHERMAN OAKS #4 - PRICE REDUCTION! (3) op comput G.P. located in a well known medical/professional building on a main thoroughfare. Cash/Ins/PPO patient base. Annual Gross Collect of approx. \$160K on a (3) day week. Great starter, satellite or buy and combine.

ORANGE COUNTY

SANTA ANA - Absentee owned (6) op fully equipped G.P. located in a smaller two story building on a main thoroughfare. First floor street frontage with exposure/visibility/signage & parking. Cash/Ins/PPO patient base with no HMO and no Denti-Cal. Computerized and Pano equipped. 2014 Gross Collections of \$549K+ on a (3 1/2) to (4) day Associate run week.

D&M SERVICES:

- Practice Sales & Appraisals
- Expert Witness Court Testimony
- Practice Search & Matching Services
- Medical/Dental Bldg. Sales & Leasing
- Practice & Equipment Financing
- Pre-Death and Disability Planning
- Locate & Negotiate Dental Lease Space
- Pre-Sale Planning

TUSTIN - (4) op TURNKEY OFFICE with some included charts. (Charts included, but not guaranteed). (3) ops eqt'd/4th plumbed. Office located in a busy shopping center, on a main thoroughfare, with exposure/visibility/signage and ample free parking. Newer high end buildout with new tile flooring, Italian leather dental chairs, digital x-rays, networked, fully instrumented, etc. Computers and Dental s/w also included in the sale. **[PENDING]**

RIVERSIDE COUNTY

Room for Your Riverside County Practice Listing.

SANTA BARBARA COUNTY

CENTRAL COAST/WINE COUNTRY - (3) op comput G.P. & 1,900 sq ft free standing bldg. for sale. Bldg. houses the dental office and a residential unit. Live in unit or rent it out! "Fee for Service" Practice. No HMO, PPO, or Denti-Cal. 2015 Projected Gross Collect \$280K part time. Growth potential. Seller refers all specialties and does little advertising. Seller retiring but will assist with Transition. **[NEW]**

SAN BERNARDINO COUNTY

RANCHO CUCAMONGA - (4) op comput. G.P. located in a large shopping ctr with excellent exposure/visibility/signage & ample free parking. Modern equipment and digital x-rays. Gross Collect \$586K in last (12) mos. Cash/Ins/PPO/Denti-Cal pts. Low overhead office. Excellent growth potential. Seller refers diff. Endo and most surgeries and does no advertising other than website. **[PENDING]**

SAN DIEGO COUNTY

Room for Your San Diego County Practice Listing.

SAN LUIS OBISPO COUNTY

GROVER BEACH - TURNKEY OFFICE. (2) ops of newer eqt. Digital x-ray and Pano. Computerized and networked. Dentrax s/w & Shick sensors. Located in a strip center on a main thoroughfare. Exposure/visibility and signage. Very low rent. Priced less than build out costs. Will go quickly. **[NEW]**

VENTURA COUNTY

CAMARILLO - (3) op comput. G.P. (2) ops eqt'd/(3rd) plumb. Located in a large strip ctr. with signage & ample free parking. Older eqt. 2015 Gross Collect projected @ \$125K+ part time. Cash/Ins/PPO pts. Low overhead office. Excellent growth potential. Seller does no advertising. Priced below build out cost. Seller retiring. **[NEW]**

OXNARD - (4) op comput. G.P. Located in a prof. bldg. with ample free parking. Dentrax s/w & digital x-rays. 2014 Gross Collect \$264K+ on a (3) day week. Cash/Ins/PPO/HMO/Denti-Cal pts. Seller refers diff. Endo & O.S., all Perio & Ortho. and does no advertising. Seller taking non profit position. **[NEW]**

THOUSAND OAKS - (4) op comput G.P. (2) ops eqt'd/(2) add. plumbed. Located in a beautifully built out condo located in a landmark prof. bldg. on a main thoroughfare. Turnkey Office w included charts. Charts included but not guaranteed. Newer Sirona eqt, Midmark cabinets, Dentrax s/w & digital x-rays. Annual Gross Collect approx. \$120K - \$130K/yr p.t. Seller moving. **[NEW]**

UPCOMING PRACTICES FOR SALE

Central Coast, Culver City, Downey, Fountain Valley, Glendale, Glendora, Hacienda Heights, Laguna Hills, Los Angeles, Mission Hills, Montebello, Palmdale, San Fernando Valley, San Gabriel, Santa Barbara, Santa Clarita Valley, Temecula, Thousand Oaks, Torrance, Union City, Ventura County, Visalia & West Covina.



"The Personalized Service
Dental Broker"

P.O. Box #6681, Woodland Hills, CA. 91365
(866) 425-1877 Outside So. CA or (818) 591-1401
www.dmppractice.com

LCF Financial Services

A Division of LCF Financial, Inc.

*With over 20 years of experience,
LCF is able to offer financing for all of your practice needs.*

100% Practice Financing!

100% Real Estate Financing!

Call Today for a Free Consultation!

Toll-Free: 1.800.550.9228
Email: Practice@lcfinc.com

Direct Line: 1.714.550.7494
Website: LCFPracticeSales.com

iTecGuide (make by CAD/CAM system for implants) 10 micron accuracy \$199. Place implants in less than one minutes info@moderntechnic.net.

Dental Laser System from Premier Laser Systems. Great condition. Photos on request. Make reasonable offer. Paul. paulkratzer@yahoo.com. 323-528-1442.

Wanted Dr. looking to rent space to see patients/build a practice. GP office in Hayward available immediately. Contact heritagedentalx2@gmail.com.

Dental Equipment for sale Used dental equipment for sale in California. Email makennabarnes@hotmail.com for available equipment and price sheet.

Wooden shelf unit Perfect for charts. Great condition. 67"x51"x12". Photos on request. Make reasonable offer. Paul. paulkratzer@yahoo.com. 323-528-1442.

CEREC 4.3 Bluecam/milling unit 2012 and Ivoclar Vivadent oven for SALE. Under Warranty. Total \$70000.00. CALL 916-920-1170.

BOARD CERTIFIED SURGEON 17 YEARS EXPERIENCE. VERY PRODUCTIVE. 3RD MOLARS, IMPLANTS, SINUS LIFTS, IV SEDATION. MODESTO-FRESNO. pwanz@ymail.com.

Wanted in Oakland CA-RDH-PT/FT energetic, friendly, and able to educate. Must know how to anesthetize. Send resume to drsarahsalman@gmail.com.

13 cases of X-LG powderfree nitrile gloves. Criterion brand. All 13 for \$500.00 + Shipping. email- hirotdental@gmail.com.

Dental Assistants needed in San Jose for high volume children's dentistry. Full time + benefits. Send resume to: dtresume@cdgdental.com.

%5 off all Osteogenics Cytoplast and buy 5 get 1 free, www.dentalprodx.com.

ULTRADENT ENDO-EZE HAND-PIECE...New-In-Box/ Unopened...(serial number: B0304343)..\$885 value/Asking \$550/obo...text/email questions/offers...310-941-8506/ BabyBoomerDentist@Roadrunner.com.

CHICO It just doesn't get any better than this! 3,000 sf w/ 7ops. Practice \$535k Real Estate \$750k (GN-507) WPS/800-641-4179.

Air Techniques phosphorus plate eraser. Great condition. Photos on request. Make reasonable offer. Paul. paulkratzer@yahoo.com. Call or text 323-528-1442.

INCORPORATE THE *RIGHT WAY!*

- Choose the right name, tax status, and filing date
- Justify a “reasonable” S corporation salary
- File all required federal/state regulatory, tax and securities forms
- Preserve the corporate identity with strong minute book maintenance

Final Result:
**Less Taxes, Limited Liability,
and IRS Audit Protection.**

**#1 Avvo® Rated Corporations
Attorney in USA**

USC Law 1984

Dartmouth College 1981



Robert W. Olson, Jr., APC

**Full Service Flat Rate Incorporations
Customized Annual Corporate Minutes
Corporate Compliance Review
Minute Book Rehabilitation**

888.963.1120

RWO@transdental.com

www.transdental.com

WESTERN PRACTICE SALES | John M. Cahill Associates

What separates us from other brokerage firms?

As dentists and business professionals, we understand the unique aspects of dental practice sales and offer more practical knowledge than any other brokerage firm. We bring a critical inside perspective to the table when dealing with buyers and sellers by understanding the different complexities, personalities, strengths and weaknesses of one practice over another.

Our extensive buyer database and unsurpassed exposure allows us to offer you...

A Better Candidate

A Better Fit

and A Better Price!

Let us provide a FREE "Opinion of Market Value" on your Practice*

*To be used for your internal purposes only, not to be confused with a formal business appraisal.

800.641.4179

westernpracticesales.com

FREMONT Gross Revenues Exceeded \$590k in '14 on 4 day work week! 1,720sf w/ 3op + 4 add'l. \$485k (BN-463) WPS/800-641-4179.

CALAVERAS COUNTY General Dentistry – 4 Ops, 1,752 sq. ft. w/Dexis Digital X-ray, Eaglesoft, Cerec, Pano. HSPPT-Dennis Hoover 209-605-9039-#CA294.

Holy Buckteeth Batman! The Dental Trader publishes free ads for dentists and staff! Details at <http://thedentaltrader.com/faqs.htm>.

HANDPIECE (MIDWEST #07-042-8854) Like New, Original Cost \$799, Make Offer. 855-772-7645 or janetm@hygiacare.com.

Ready to build your dream practice? Allow Live Oak Bank to finance your construction project with up to 100% financing. 877.890.5867 www.liveoakbank.com/healthcare.

8 chairs doctor and assistant chairs. \$250 for all. used good condition. 949-661-6255 ask for roberta.

Complete Sensor and Practice Management with EHR. Package includes everything you need to take x-rays and collect your money from insurance and track your patient's care. Call 1(800)397-6046.

BAKERSFIELD #31 (4) op comput. G.P. & free stand. Duplex Bldg. for sale. Excellent signage & visibility. (3) ops eq't'd / (4th) plumbed. Cash/Ins/PPO pt base. No HMO & no Denti-Cal. (46) years of Goodwill. Annual Gross Collections approx \$350K. Office does no advertising. Refers out all Ortho, Perio Surgery, Implant Placement, complicated Endo & O.S. D&M Practice Sales 818.591.1401.

SHARE SPACE in ROCKLIN beautiful state of art fully furnished 5000Sqf ,operatory set up for Orthodontist or Pedo, room for X-ray Lab contact Ana destinydentalimplant@gmail.com.

dental lab pressure pot \$88 OBO 3109805265.

Attention all Dental offices. Pediatric Dentists, Orthodontists, Perio and Endo specialists are using www.upsurg.com to find work.

PRACTICE FOR SALE RANCHO MIRAGE. Estab GP in Busy, Upscale retail center. 4 Ops in 1500 sq. ft. LOTS referred Out!! SDPS: 769-599-7828.

Intraoral Cameras INVENTORY REDUCTION! Best Technical Support and Warranty. Use PROMO code TRADER on www.Lensiora.com for our clearance pricing!



San Diego Practice Sales

*SAN DIEGO'S MOST EXPERIENCED,
TRUSTED & ACTIVE BROKER (since 1990)*

We have sold HUNDREDS of Practices totaling several MILLIONS of Dollars!!

VISTA – JUST LISTED!! GENERAL Practice situated in Retail Center along VERY busy thoroughfare. 4 Ops (3 equipped) in approx. 1400 sq. ft. ALL Digital and Paperless! Dentrux Software. Panorex. All Insurance and Cash Patients.

LA MESA – JUST LISTED!! GENERAL Practice and **BUILDING** located on Busy thoroughfare. 5 equipped Ops (plus 1 plumbed) in approx. 2700 sq. ft. Digital X-Rays and 1 year old Digital Pan.

NATIONAL CITY – JUST LISTED!! GENERAL Practice with 3 Ops with 4 year old equipment. Approx 1163 sq. ft. Situated along busy street in business/residential area.

RANCHO MIRAGE – Doctor retiring from estab. **GENERAL** Practice situated in Busy, Upscale retail center. 4 Ops in 1500 sq. ft. Pan-Ceph. Owner refers out LOTS of dental care!

OCEANSIDE – Equipment and Leasehold Improvements. 3 ADEC Ops (1 more plumbed) in 1375 sq. ft. Introral Cameras, Panoramic, Digital X-Ray, Rotary Endo, and more. Owner leaving country. VERY low price for quick sale!!

MIRA MESA – 20+ year **GENERAL** Practice has 4 Ops in approx. 1300 sq.ft. Situated on corner of busy intersection. Primarily PPO.

LEMON GROVE – **GENERAL** Practice in high traffic strip mall. 4 Ops in 1100 sq. ft., has digital. Cash, PPO, Cap. Absentee owner.

Also Serving The INLAND EMPIRE!!

Practices available in **COLTON, SAN BERNARDINO, MURRIETA**

for updates, please visit us at
WWW.SDPRACTICESALES.COM

SAN DIEGO PRACTICE SALES can also assist you with *PRACTICE APPRAISALS, BUY-IN BUY-OUT TRANSACTIONS and LEASE NEGOTIATIONS.*

For More Information Call:

Mike Hostler (760) 599-7828 Bob Fleming, D.D.S.
(voice mail)

SERVICE -- INTEGRITY

SAN BERNARDINO by the University, 4 ops., 3 equipped, Dentist retiring with 20 years of goodwill. Great price! Great potential! iepracticesales.com (951) 816-6242.

SANTA CLARA El Camino Real location. 2015 tracking \$775,000 with Profits of \$325,000. Management on "cruise control." New Doc who is ambitious and extends hours shall push practice over the \$1 Million bar very quickly. To learn more, go to www.PPSsellsDDS.com or send an email to Ray@PPSsellsDDS.com.

FRESNO General Dental Practice & Building FOR SALE contact Brooke at 714-259-0501 for more details.

DENTAL PRACTICE FOR SALE IN ONTARIO Starter Practice on main street. Low Rent! 3 operatories. Call Loc Pham, Broker at LCF BRE#01875780. (714)550-7494 7494 or practice@lcfinc.com | LCFPracticeSales.com.

TOUCH N HEAT UNITS New & Refurb ORIGINAL U.S. Made 4NuBuchanan Tips Included 3 Years Warranty \$855 For more Info: eismaildds@yahoo.com.

"Dear Pat I truly appreciate all the hard work and thoughtfulness you put into this whole endless ordeal. Your calm manner during my highly stressful process was invaluable. I am grateful for your tireless persistence. You are now part of my dream team. Take good Care" LYNN LEMPERT, DDS Beverly Hills, California. CALL TODAY 800-499-1474 WOOD & DELGADO www.dentalattorneys.com.

PEDIATRIC DENTIST needed, space for starter practice in East Bay orthodontic office, our community NEEDS good pedo! (510) 384-5553.

GILROY Facility This traditionally styled practice is perfectly situated! 1,325 sf w/ 3 ops + 1 add'l. \$75k (DN-467) WPS/800-641-4179.

Financing for your practice and so much more. We can help you reach your practice goals. Call Wells Fargo Practice Finance at 1-888-937-2321 or visit us at wellsfargo.com/dentaltrader.

LIVERMORE General Practice & Building. Approx 1,100 sq. ft., 4 ops, digital X-ray & Pan, Laser. 2014 GR \$740K. HSPPT-Jim Engel 925-330-2207-#CA300.

Traveling Orthodontist Orthodontist available locum tenens and part-time, perfect for vacation or adding ortho to your general practice. travelorthodontist@hotmail.com.

Our 9th Annual Dental Skills Series in San Jose includes an Endo Lecture and an 8 CE Intro to Dental Sleep Medicine...only \$299 and 15 CE's! Visit www.xcelseminars.com for info.

If you have cell service...



...you have
The Dental Trader!
 As mobile as you are.
dentaltrader.com

LCF Practice Sales & Financing

Free consultations for Buyers & Sellers
BUY PRACTICE • SELL PRACTICE • FINANCE PRACTICE

ATTENTION SELLERS!

We currently have
Pre-Approved
 Buyers for dental
 practices located in
**Orange County,
 Los Angeles,
 Riverside,
 San Fernando Valley,
 San Diego County
 and the Bay Area.**

Call to List
 Your Practice
 With Us Today!

Toll-Free:
1.800.550.9228

Upcoming Listings:

- Downey
- Riverside
- San Juan Capistrano

"My relationship with LCF Practice Sales has been strong from the beginning. I have worked with Loc Pham as a buyer, seller, and as a financing client, and I have been consistently impressed with his professionalism and hard work."

- Dr. Joel Manalese, D.D.S.

We Offer Up to 100% Practice Financing!

- Practice Sales
- Working Capital
- Refinance/Consolidate
- Equipment Leasing
- Real Estate Acquisitions
- and So Much More!

Dental Practice for Sale Los Angeles County, CA

Gardena - Busy Intersections

- Strip mall nearby anchor stores.
- High Traffic. Great Visibility.
- 4 Operatories, ~2,100 sq.ft.

Long Beach - Busy retail center

- Perfect location for a Starter Practice. Major anchored stores.
- Affordable Rent. ~1,000 sq.ft.
- 3 Eq. Ops + 1 add't plumbed

Long Beach - 20 Yrs of Goodwill

- 5 Operatories, ~1,300 sq.ft.
- Mixed Income & Stable Pt Base

Los Angeles - Gross ~\$400K

- Highly Visible from busy streets.
- Affordable Rent! Cash/PPO
- 3 Eq. Ops plus 2 add't chairs.

Los Angeles - Gross ~\$356K

- Well Known Medical Building Close to Retail/Shopping Center
- 4 Operatories, ~ 1,397 sq.ft.

Santa Monica - Gross ~\$300K

- Seller Retiring. Highly Visible
- 4 Equipped Ops, ~ 1,397 sq.ft.

South Gate - Gross ~\$150K

- Seller Retiring. Shopping Ctr.
- Excellent Visibility & Signage
- 4 Equipped Ops, ~1,200 sq.ft.

Valencia - Gorgeously Design

- Real Estate & Practice for Sale
- Projected Gross 2015 ~\$870K
- State of the Art Practice
- Increasing Revenue, Cash/PPO
- 6 Operatories, ~2,200 sq.ft.

Dental Practice for Sale Fresno County, California

Coalinga - Freestanding Building
Gross ~\$589K on 3-4 days/wk.

- Located on busy main street
- Excellent Visibility.
- Paperless Office.
- 3 Fully Equipped Operatories
- Approx. 1,200 sq.ft.

Dental Practice for Sale San Diego County, CA

La Jolla - Gross ~\$350K

- Retail Center, digital office.
- Mostly PPO, 2 Equipped Ops.

Dental Practice for Sale Orange County, California

Laguna Hills - Beautiful Office

- Projected Gross 2015 ~\$400K.
- Increasing Revenue. Cash/PPO.
- Busy Retail Shopping Center.
- 4 Eq. Ops, Approx. 1,750 sq.ft.

Mission Viejo - Gross ~\$1.2 Mill

- Large Shopping Center
- Mostly PPO/Stable Pt Base
- 7 Operatories, ~2,700 sq.ft.

Santa Ana - LOW RENT!

- Highly Visible Corner Office.
- Busy Street. High traffic
- 3 Eq. Ops, Approx. 1,100 sq.ft.

Santa Ana - Gross ~\$345K

- Main Street, Downtown
- Mostly Dential, ~2,392 sq.ft.
- 5 Eq Ops + 2 Add't Plumbed

Dental Practice for Sale Riverside County, CA

Moreno Valley - Gross ~\$235K

- Stand Alone Building & Dental Practice for Sale
- High Visibility on Busy Street
- 4 Eq. Ops + 5 Add't Plumbed
- 2,500 sq.ft., 9-10 Parking Space

Dental Practice for Sale San Bernardino County, CA

Ontario - New Listing!

- Starter Practice on busy main street. Excellent visibility.
- Seller retiring. Low Rent!
- 3 Equipped Ops, ~1,100 sq. ft.

San Bernardino - Starter Practice

- Asking \$25K or Best Offer!
- 1063 North D Street
San Bernardino, CA 92410
- Private parking in the back.
- 2-3 Equipped Ops / 4 Plumbed
- Low Rent! ~1,163 sq.ft.
- No Patient Base.

Buy Two Practices Together

Dental Practices for Sale in Rialto & Rancho Cucamonga

- Practices Gross ~\$906K
- Both Dental Practices are in Large Retail Centers.
- Rialto: ~3,500 sq.ft. 8 Ops
- Rancho: ~2,100 sq.ft., 5 Ops.
- Don't Miss This Opportunity!

Dental Practice for Sale Northern California

**Concord - Gross ~\$125K
 Practice & Real Estate Available**

- Freestanding building
- Mostly Cash/PPO. Good visibility.
- 2 Eq Ops + 2 Plumbed, 1,500 sf

Dublin - Gross ~\$785K

- Prime location. Shopping Center
- Mostly PPO/Cash Patients
- 5 Operatories, ~1,800 sq.ft.

Fremont - Gross ~\$485K

- Busy main streets, ~2,000 sf.
- 4 Eq. Ops + 3 Add't plumbed.

Gilroy - Gross ~\$243K

- Large shopping center.
- 3 Eq. Ops + 2 add't plumbed.

Hayward - Gross ~\$438K

- Located in shopping center.
- Mostly Cash/PPO, ~1,800 sf
- 4 Eq Ops + 1 Add't Plumbed

King City - Gross ~\$650K.

- Large retail shopping center.
- Over 10 Years of Goodwill
- 5 Eq Ops, ~ 1,375 sq.ft.

Modesto - Gross ~\$300K

- 3 days a week for past 3 years.
- Long established patients
- 4 Eq Ops + 1 Add'l plumbed

Modesto - Gross ~\$830K

- GP located in strip mall.
- Cash/PPO, ~ 3,200 sq. ft.
- 7 Eq Ops + 1 Add'l plumbed

Salinas - Gross ~\$243K

- Shopping center. Cash/PPO.
- 3 Eq. Ops + 2 add't plumbed.
- Very little competition around.

San Jose - Great Location

- Strip Mall. Busy Street.
- 3 Eq. Ops, Approx. 1,040 sq.ft.

**San Jose - Stand Alone Bldg.
 Asking \$15K or Best Offer!
 Starter Practice w/ Patient Base.**

- 5 Eq. Ops, Approx. 2,000 sq.ft

For our complete
 listings, visit us at
LCFPracticeSales.com

or Call Today at
 (714) 550-7494
 (800) 550-9228

Call Loc Pham, Broker (714) 550-7494 for More Information!

Email: Practice@lcf-fin.com | Website: LCFPracticeSales.com

A Division of LCF Financial, Inc. BRE #01875780

CAVITRON ULTRASONIC SCALER (Select SPS 30k) (#81302) & Reservoir Pump (#90146) Like New, Original Cost \$2,758, Make Offer 855-772-7645
janetm@hygiacare.com.

Well slap my butt and call me Spanky...I can subscribe, change my address or cancel my free Dental Trader subscription anytime at <http://www.thedentaltrader.com>.

ROCKLIN Facility Don't miss out on this remarkable opportunity! 2,150 sf w/ 4 ops. \$150k (EN-464) WPS/800-641-4179.

FOR SALE Star Titan-3 Slow Speed Like New Without swivel. Motor only. Angle Adaptor and Contra Angle available. (323)851-6622.

Are you looking for an Oral Surgeon, Periodontist or Endodontist to team up at your office? Contact Synergy Specialists. Our network has a full team of two dozen of the most clinically efficient, team work frame minded specialists in the industry motivated to team up with offices. info@synergyspecialists.com.

RDA COURSES Coronal Polishing, Radiation Safety, Infection Control, BLS/CPR. CEUs \$19 Online: 2 Hr Infection Control, Dental Practice Act.(888) 988-2364 www.ADMInstitute.com.
info@adminstitute.com.

Glendale Prestigious, high-tech general and cosmetic practice. Real estate available also. IntegrityPracticeSales.com, Broker Bill Kimball, DDS, BRE #01911548. (855) 337-4337.

Global dental microscope Excellent condition Floor stand. G4. Carr extender. LED. Camera/video capable. Dental composite filter. \$20K. Call 6192411979.

DENTAL PRACTICE FOR SALE IN LOS ANGELES. GP in shopping center. Major anchor stores. 7 operatories, 2,300 sqft. #LA70A. Call Loc Pham, Broker at LCF BRE#01875780. (714)550-7494 or practice@lcfinc.com | LCFPracticeSales.com.

ANESTHESIOLOGIST Dentist Anesthesiologist serving your Central Coast office SLO to Camarillo. Competitive Rates. Wednesdays or Saturdays available currently. 630-723-1946. erikdwinn@hotmail.com.

Calling all Dental specialists! Dental offices are now using UpSurg to find a dental specialist.
www.upsurg.com.

\$1000 Rebate on Dry Vacuum System, \$3995 update your old vacuum system to New Drought Tolerant Standards. Made in USA. Call (800) 423 - 5657 or visit DHPDENTAL.COM for more details.

Clean out that junk drawer and sell the stuff you don't need.

Place a **FREE AD** and turn your unwanted items into cash! Ads placed online post instantly to our website.

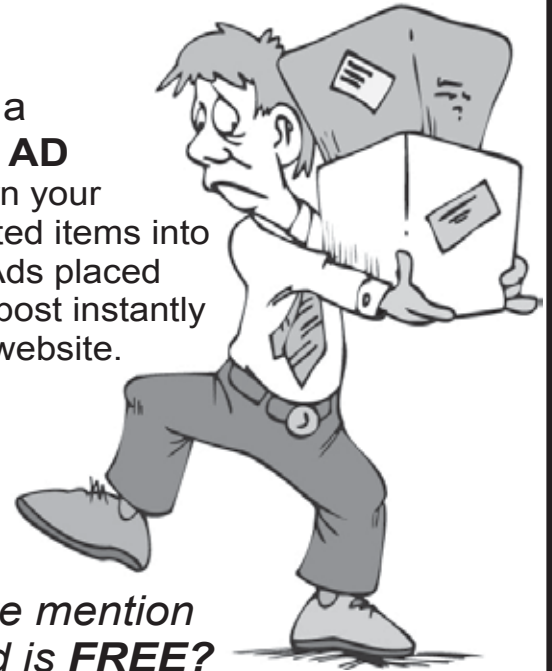

Did we mention the ad is FREE?

Visit our FAQs page at dentaltrader.com for details

New Gendex GXC300 intraoral camera. Retail \$3789. Comes with case, sheathes, software driver and user manual. \$3000 OBO. Call 858-531-5410.

REDDING Pristine and attractive! Conveniently located! 2,100 sf w/ 3 ops + 2 add'l. Now Only \$300k! (GN-258) WPS/800-641-4179.

Hospital Grade Synthetic exam gloves \$39.68 per case of 1,000, Nitrile "Sensicare Silk" exam gloves \$171.05 per case of 2,500 (boxes of 250). That's \$.07 per glove! www.dentalprodx.com.

SHASTA COUNTY, CA Grossing \$851K, Beautiful Office, Est 25 Yrs, 6 Ops - 100% Financing Available. Call ProMed 888-277-6633 [Ref #D238].

FOR SALE Mid-West Tradition F/O Small Head--Push Button Just overhauled 6-month warranty Like New Great Price (323) 851-6622.

Brand new Dynamix speed 66045802 (henry schien \$2300.00) ask for 1500.00 OBO, call 562 328 3626 Dr. Lee.

PRACTICE FOR SALE NEW!! GP in VISTA along VERY busy street. 4 Ops (3 equipped) in 1400 sq.ft. DIGITAL & PAPERLESS. Panorex. Insurance and Cash. SDPS: 760-599-7828.

YEAR END

Vacuum Pumps - 1 HP

\$1696 / \$1295

3 Available



The Precision 1 Horsepower Vacuum System is engineered with Naval Brass and Warranted for 5 Years. It is available in 120v or 240v and easily installs in Any Dental Office. A cost effective solution for a "Back Up" system.

Oil Less Air Compressor - 1 HP

\$3295 / \$2795

2 Available

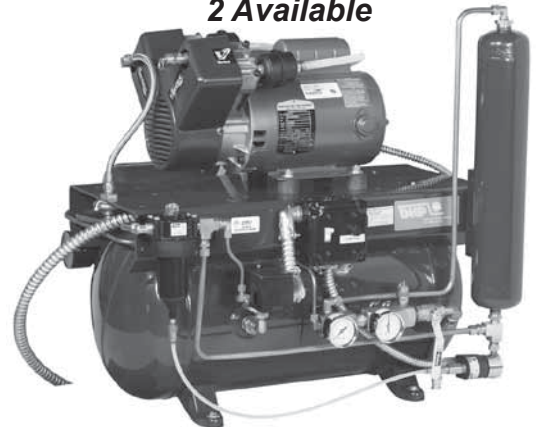

The Clean Flow 1 Horsepower Oil Less Air Compressor is outfitted with a Complete Air Drying System and Air Intake System. It will easily deliver clean dry air to 4 - 5 operatories and it manufactured in the USA. It comes with a 5 year warranty.

Oil Less Air Compressor - 2 HP Dual

\$4295 / \$3795

2 Available

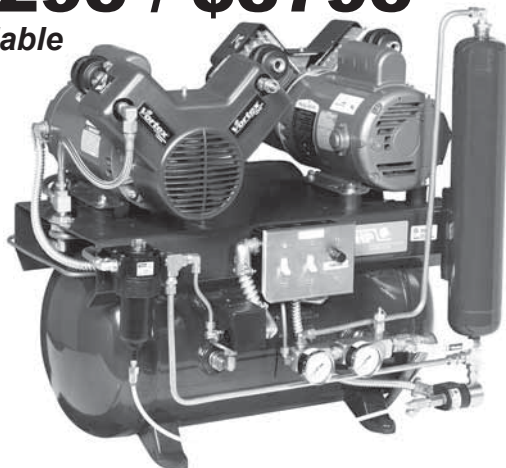

The Clean Flow 2 Horsepower Dual Motor Oil Less Air Compressor is outfitted with a Complete Air Drying System and Air Intake System. The dentist can choose to operate either Oil Less Motor or can use both to supply clean dry air to as many as 10 operatories it manufactured in the USA. It comes with a 5 year warranty.

Vacuum Pump - 2 HP Dual Motors

\$3495 / \$2895

3 Available

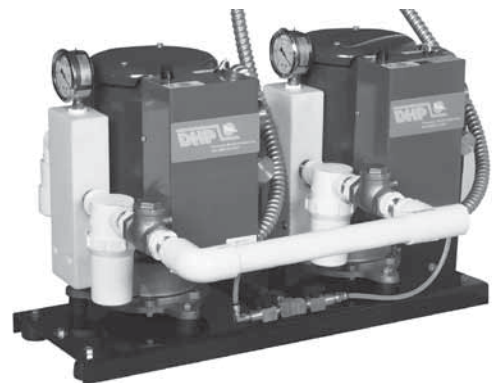

The Precision 2 Horsepower Dual System is designed so the dentist can use either of the Vacuum Pumps or use them in conjunction and create a powerful dual motor Vacuum to ensure quality intraoral evacuation. They are Made in USA and come with a 10 Year Warranty.

Dansereau Dental

BLOW OUT!

Diamond Dental Light

\$895 - \$595

5 Available

Quality Dental Light with High and Low Features, installs on Any Dental Chair.

Halogen light with adjustable light pattern and non drifting dental light arm are integrated in the Diamond Dental Light.



All this equipment is new and fully warranted.

Roadrunner "Hybrid" Dry Vacuum System

\$5295 / \$4295

3 available



Infinity LED Dental Light

\$1595 / \$795

7 Available

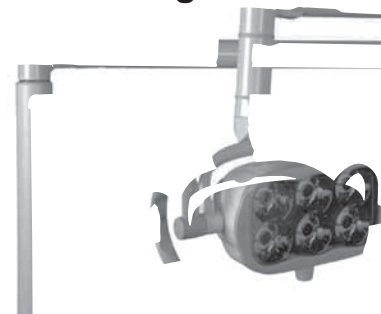

LED Dental Light with a Cool Light Source, Adjustable Illumination installs on Any Dental Chair. The Infinity Dental Light includes 3 way articulating light head and true natural lighting to reduce eye fatigue and reduce or eliminate quick curing of bonding materials.

Infinity Delivery System with Asst Package

\$2595 / \$1895

4 Available

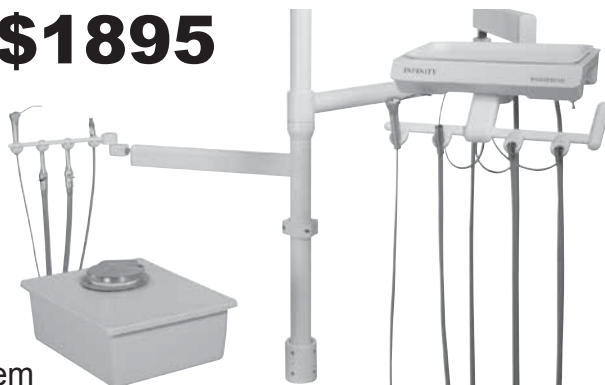

Upgrade your Old Tired Delivery System

with a New Delivery System, Complete with 3 Handpiece Automatic Unit and 3 Way Syringe. All mounted on Air Locking Flex Arm. The Telescoping Assistants Package includes a 3 Way Syringe, 2 HVE and 1 Saliva Ejector and the Complete Dental Junction Box. It will mount on Any Dental Chair and comes with the confidence of an American Manufacture Product with a 10 year Warranty.

The Roadrunner Dry Vacuum System is truly a "Hybrid" with the combination of the variable speed operation, a "Real Time" sensor increase vacuum as needed by the dentists use, and the non use of water in the vacuum system it will reflect in short term and long terms savings for the dentist.

MADE IN THE USA

Phone: (800) 423-5657

Website: WWW.DHPDENTAL.COM • Email: Harry@DHPDENTAL.COM

A Different Kind of Dental Attorney

I know dentistry's unique legal & financial challenges

Services

Incorporation

Estate Planning

Buy/Sell Agreements

Lease Reviews

Space Sharing
Agreements

Workers' Compensation

Practice Sales

**Call us
for other services!**

Member

CA State Bar

NC State Bar

US Federal Courts

US Federal Tax Courts

Calif. Dental Licensure

Testimonials:

Jeng and Associates have represented me in buying 3 offices and multiple lease reviews and negotiations. Their professionalism is unbeatable and Dr Jeng is always available to answer my questions by phone or email.

Dr. L. Kong, Daly City, Ca

I highly recommend Dr Jeng as a dental attorney. His experience as a dentist combined with his legal experience gave me the confidence to enter into a share office arrangement. He was always available to answer my calls and addressed all my concerns and questions.

Dr. P Tran, Burbank, Ca

Dr. Chester Jeng represented me in my last two dental office purchases. Very professional and helpful. He is my go to lawyer for my legal needs.

Dr. K Chou, Hacienda Heights, Ca



Law Offices of Jeng and Associates Chester Jeng, DDS, JD, LL.M

Cell: (909) 450-7158 • (714) 858-0536

Jenglaw.com • Jenglaw@yahoo.com

1440 North Harbor Blvd., Suite 900, Fullerton, Ca. 92835

*Disclaimer: Monthly tip is not legal advice and in no way attorney-client privilege has been created. Consult a CPA or attorney if you need tax or legal advice.

GENERAL DENTIST NEEDED FOR OUR PRIVATE OFFICE IN SAN LUIS OBISPO COUNTY. EXPERIENCE DENTIST SEEKING PART TIME POSITION (3 DAYS A WEEK) WITH THE OPPORTUNITY TO BUY OUT. FORWARD RESUME CDKRILLDDS@ATT.NET, BY FAX AT 805-239-9097 OR CALL FOR AN INTERVIEW 805-801-2654.

Is it time to consolidate your loans? Let's talk about how we can work together to simplify your finances. Call Wells Fargo Practice Finance at 1-888-937-2321 or visit us at wellsfargo.com/dentaltrader.

GP Dental Office For Sale: San Francisco Bay Area 4 OPS/Pano/1500sq. Free Standing Building Low Expenses/ Owner retire. Cell: 510-619-4240.

PERIO PRACTICE SAN FRANCISCO'S NORTH BAY Highly regarded and located in desirable family area. On 3.5 day week, 2015 revenues shall top \$1 Million with strong profits. Beautiful facility with 4-Ops. To learn more, go to www.PPSsellsDDS.com or send an email to Ray@PPSsellsDDS.com.

MADERA General Building & practice. 6 Ops, 3000 sq. ft., Dentrix software, Dexis software, Pano. 2014 GR \$850K. HSPPT-Dennis Hoover 209-605-9039-#CA289.

INTRAORAL CAMERA (2)-Magenta MD960U, Like New, Original Cost \$249 each, Make Offer 855-772-7645 or janetm@hygiacare.com.

DUBLIN Facility Shared Facility. Great for Specialist-Endo, Pedo or Ortho. 1,100 sf w/ 2 ops +1 add'l \$125k (DC-473) WPS/800-641-4179.

SAN FERNANDO VALLEY (8) Op fully eqt'd comput G.P. w central nitrous for sale. Located in a multi story high rise prof. bldg. on a main thoroughfare. Cash/Ins/PPO/HMO pt base with approx. \$7K+/mos Cap Ck. Dentrix, Digital X-Rays, & Digital CT Scan. 2014 Gross Collect \$1.33M+. 2015 Projected Collect \$1.4M. Open (5) days/week w no nights & no weekends. Averaging 50+ new pts/mos. (5) Hygiene days/wk & (7) DDS days/wk. Refers out Ortho, some Endo and some Perio surgery. D&M Practice Sales 818.591.1401.

"Jason, thank you so much for revising and reviewing my dental contract. I now have a comfortable sense of security." EVA K. SWENSON, DDS. CALL TODAY 800-499-1474 WOOD & DELGADO www.dentalattorneys.com.

DENTAL PRACTICES WANTED in San Luis Obispo, Santa Maria, Santa Barbara County Production 300K+. Retiring Seller is ideal. Sellers call Loc Pham, Broker at LCF Financial, Inc. BRE#01875780. (714)550-7494 or practice@lcfinc.com | LCFPracticeSales.com.



The Dental Trader
wishes you a
very Merry Christmas,
Happy Holidays
and a Happy New Year!

Intraoral Cameras ANNUAL SALE! Get distributor pricing using PROMO code TRADER on www.Lensiora.com. Offer limited to inventory on hand!

Associate needed Full-Time in the Central Coast multiple locations available. Possible partnership for the right candidate. Base pay plus production, new graduates welcome. Send resume to friendlismilesdentalgroup@yahoo.com or fax to (805)928-6788.

Associate Wanted Ukiah, Northern California General dentist office looking for an associate for 3 to 4 days a week. please email resume to parkfallental@yahoo.com.

Thomas Sudbijo, DMD (Tustin, CA)-Law Offices of Jeng and Associates is definitely one law firm that I will continue to use for my legal needs. Dr. Jeng was very helpful addressing my questions and was on top of things and kept me informed in every step. Call Jeng & Associates 714-858-0536.

One man's treasure is another's useless crap. Clean out that junk drawer and turn your unneeded items into CASH by advertising them in The Dental Trader FREE! Visit <http://thedentaltrader.com/faqs.htm> for instructions on placing a free ad today.

HOW DO I KNOW WHEN TO SELL?

&

Who can I trust
to help me
NAVIGATE THE SALE?

(855) DDS - 4DDS (855) 337-4337

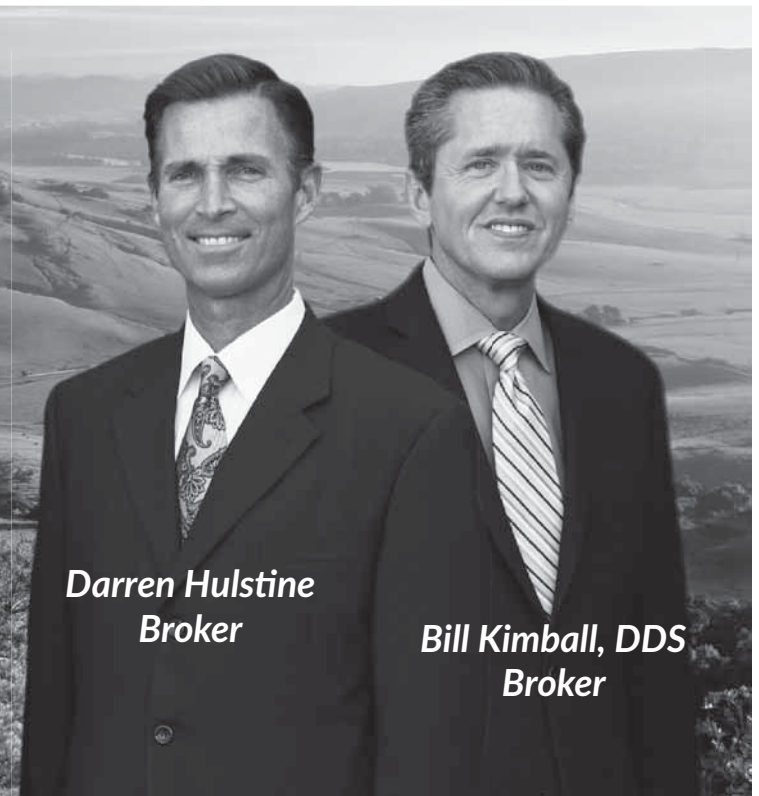

Darren Hulstine
Broker

Bill Kimball, DDS
Broker

San Luis Obispo Practice

Incredible opportunity to practice in the happiest city in America. Beautiful area to raise a family or retire. Laser periodontist seller does not place dental implants, so there's a huge potential for growth. Beautiful 1,100 square foot office with 4 equipped operatories. The seller is willing to retire or to partner with the right periodontist. Beautiful and well equipped office. Easy parking. Friendly team. Dr will entertain all offers and parties for either half or the whole practice. Half practice valued at \$320,00. Call today for a showing.

Glendale Practice

Prestigious, high-tech general and cosmetic practice. Beautiful office with great exposure. Great space at 1,000 square feet and 4 equipped operatories. Experienced team. Located in busy Glendale near great shopping and entertainment (about a mile from Glendale Galleria). Collections have been consistent for several years. Close to freeway with easy parking. Real Estate available priced separately. Call today for a showing.

Santa Barbara Practice

This well-established multi-generational practice has proven to be a winner. With 3 operatories and 600 sq. ft. you'll love the cottage feel. This is the perfect opportunity for a first time buyer and serves an elite patient base with features like digital charts and digital x-ray. A very friendly and motivated team make this 3-day-a-week practice a comfortable investment and it's ready to grow. This practice is positioned minutes from downtown and the beach. The practice is booked out in advance with almost no openings. Landlord is friendly and eager to work with the new dentist. Please call us for a showing.

SAN JOSE - Pending

SANTA MARIA - High quality personal dentistry

SANTA MARIA - Call for details

ORCUTT - Established 30 years, great visibility

NORTH SANTA BARBARA COUNTY - Call for details

SANTA BARBARA - Call for details

GLENDALE - 5 ops with lots of upside potential

GLENDALE - 5 ops, downtown just minutes from Galleria

NORTH TUSTIN - Call for details

WESTLAKE VILLAGE - Great location

THOUSAND OAKS - Turn key opportunity

RIDGECREST - Real estate also available

VISTA - 4 ops, nice practice

LA HABRA - Dr. retiring, opportunity to own

RANCHO CUCAMONGA - Pending

SAN BERNADINO - Pending

ENCINITAS - Call for details

www.integritypracticesales.com
kirsi@integritypracticesales.com



CA BROKER #01911548
CA BROKER #01899816

Experienced and Responsive Dental Attorney



Cecilia Chen, Attorney
Super Lawyer 2014
Nominated by Peers

"I thought all attorneys were the same. But after seeing the frustration from the seller because of her lawyers, I knew that I have someone special on my side. Cecilia was thorough, efficient, and worked with my budget."

Jack W. Chan, DDS

"Cecilia represented me in the sale of my dental practice to my existing partner. She was very professional, thorough and easy to communicate with. The other attorney was contentious and uninformed about complex insurance issues and made no effort to preserve goodwill. Cecilia is very knowledgeable in dental practice law, particularly when it comes to partnership buyouts and practice acquisition. She went the extra mile to try and ensure that my interests were protected."

Richard Lindsay, DMD

"Her fees are very competitive and reasonable. In fact, her fees were entirely covered with a 3-months rent abatement that she had went out of her way to negotiate for me in a lease assignment."

D. Aminov, DMD

Serving Dental Professionals:

- Practice Sales and Acquisitions
- Lease Review and Negotiation
- Partnership Formation and Buy-Out
- Practice Start-Up and Incorporation
- Associate and Fee Sharing Agreements
- Estate Planning



LAW OFFICES OF
CECILIA CHEN

Toll Free: 855.850.4111

Email: cecilia@practiceatty.com

www.practiceatty.com

12.15

SOLANO COUNTY Highly visible location! 2,997 sf w/ 6 Dr ops + 2 Hyg ops +1 add'l \$850k! (CC-456) WPS/800-641-4179.

Associate Wanted Ukiah, Northern California General dentist office looking for an associate for 3 to 4 days a week. please email resume to parkfalldentist@yahoo.com.

OCEANSIDE Just Listed! Equipment and Leasehold Improvements. 3 ADEC Ops, Intraoral Cams, Panoramic, Digital and more. VERY Low Price. SDPS: 760-599-7828.

Staff exam gowns for \$26.17 per case of 50 polypropylene elastic wrist yellow or blue. www.dentalprodx.com.

For Sale Adec unit light \$875.00 Belmont intra-oral X-ray machine \$895.00 Email: pacificdental65@gmail.com.

INLAND EMPIRE PRACTICE SALES - SERVING THE INLAND EMPIRE EXCLUSIVELY!! LOCAL, PERSONALIZED SERVICES FOR DENTAL PRACTICE SALES AND PURCHASES. CALL TOM @ (951) 816-6242. iepracticesales.com. A subsidiary of San Diego Practice Sales.

REAL ESTATE | ACQUISITION | EXPANSION | NEW CONSTRUCTION | REFINANCE | START UP

WE'VE GOT YOUR BACK, FROM BREAKING GROUND TO FINAL BRICK.



With financing designed to preserve your cash, you can get started on your new office today.

Let your Dental focused lending team and dedicated construction team carry the weight. Contact one of our lenders to get started.



JP Blevins
General Manager
910.796.1674



Mike Stanton
Loan Officer
404.995.2003



Mike Montgomery
Loan Officer
910.798.1215



Lindsay Harkey
Loan Officer
910.550.2277



LIVE OAK BANK
liveoakbank.com

Visit liveoakbank.com/dental-trader for your free guide to "Managing Your Financial Profile"

©2015 Live Oak Banking Company. All rights reserved. Member FDIC

Dental Instruments New or like new Rubber Dam Punches (6 -all Hu-Friedy) Clamp Removers (12) Cotton pliers (5)(323) 851-6622.

ULTRASONIC (PATTERSON PA-4) Like New, Original Cost \$450, Make Offer. 855-772-7645 or janetm@hygiacare.com.

FACT An ADA study demonstrated that 1 out of 3 dentists will be disabled long enough to collect benefits. Call us for a **FREE Disability Insurance Appraisal 855-346-9729 di4dds.com.**

Looking to purchase new/lightly used LED Curing Light. Please text/call 323-819-6714 with brand, model, and price. Thank you.

MILLBRAE General Dentistry- 1,500 Sq. Ft., 5 Ops, 1 additional plumbed, state-of-the-art equipment. 2014 GR \$670K. HSPPT-Jim Engel 925-330-2207-#CA262.

DAVIS Rare Opportunity! 4 ops each w digital xrays. No corners cut here! \$320k (EN-477) WPS/800-641-4179.

Searching for the right bank? Look no further than Live Oak Bank. Our lenders understand your business and specific financing needs. 877.890.5867 www.liveoakbank.com/healthcare.

HYGIENE INSTRUMENTS FOR SALE, various cassetts, scalers, basic sets, syringes, sharpening stone, probes, slow speed. \$1,500 OBO Darabantp@yahoo.com.

Legal Tip Does your attorney provide his cell phone number for emergencies? Attorney Robert W. Olson, Jr., 805.963.1120, www.transdental.com.

SACRAMENTO DENTIST needed,new grads welcome! Bilingual English/Vietnamese Full time/ Part time Fax :(916)399-9413.

SAN LUIS OBISPO Perio practice. 4 ops. Upscale equipment. Purchase the full practice or half. IntegrityPracticeSales.com, Broker Bill Kimball, DDS, BRE #01911548. (855) 337-4337.

CAVITRON SCALER TIPS OLDER, BUT FUNCTIONAL 11 USED, 3 BRAND NEW IN BOX. \$1200 EMAIL OR CALL/TEXT DOCJTY@GMAIL.COM, 310-292-7812

CLOUD BASED TELEPHONE SYSTEMS for Dental Offices. Simple, flexible, and powerful voice and data solution at a very affordable price. Cutting edge technology allows dental offices to utilize a fully hosted PBX and offer you the latest phone and Internet technologies without the need and cost to purchase your own onsite PBX. Call 800-273-5033. Or visit: www.eZ2000dental.com, then PRODUCTS, then TELEPHONE / INTERNET SYSTEMS.



AWESOME

“Two hours after placing my practice for sale ad on The Dental Trader website, I received my first inquiry. On the first day I had three interested buyers. If you want results, I recommend advertising in The Dental Trader.”

Dr. Seo

SAN JOSE Facility Only. 1,600 sf w/ 3 ops. Real Estate also available for purchase \$120k / Real Estate \$1.5M (DC-370) WPS/800-641-4179.

FOR SALE Impact Air 45 Surgical Handpiece Not F/O. New turbine and head cap. Just Overhauled 6-month Warranty (323)851-6622.

Modern & mobile websites perfected for Dentists. TheDocSites.com \$0 Set Up For Dental Trader Readers! Risk Free! Limited Time Offer.

Wanna save paper? Retired but your dental license is still active and wish to remove yourself from the Dental Trader mailing list? Go to <https://secure40.secureweb-session.com/thedentaltrader.com/cancellationsecure.htm> and you will be automatically removed from our current list and all future mailing lists we buy. You'll save a tree too!

Menifee, CA Turnkey Dental Office 4SALE \$65K with some patient charts. 4 plumbed Ops/2 equipped. Growing area. 310-863-5779.

Attend an Endo Lecture and an 8 CE Intro to Dental Sleep Medicine for only \$299, Both on Sundays (15 CEs), in a convenient San Jose location! Visit www.xcelseminars.com for info.

If delivering a better dental experience for your patients is your goal, upgrading or expanding your practice is one of the best investments you can make. Call Wells Fargo Practice Finance at 1-888-937-2321 or visit us at wellsfargo.com/dentaltrader.

DANSEREAU CHAIR FULLY FUNCTIONAL. YELLOW FRAME WITH VINYL/FABRIC UPHOLSTERY FOR PICKUP IN TORRANCE \$300. EMAIL DOCJTY@GMAIL.COM, 310-292-7812 CALL/TEXT.

PRACTICE FOR SALE MIRA MESA. 20+ yr GP, 4 Ops. in 1300 sq.ft. PPO: SDPS: 760-599-7828.

We are looking for established doctors interested in selling their practices & remaining long term associates. **Our acquisition is designed to defer taxes in the sale until your retirement & allow you to continue making a substantial yearly income.**



Does your practice collect more than \$300k annually?



Are you tired of managing staff, insurance billing & other business related issues?



Streamline
DENTAL SOLUTIONS



Would you like to “cash out” of your practice & still work there?



Would you like to shield the purchase price from paying taxes now?

For more information, please contact us via email at Info@streamlineden.com

Sterilization pouches 3.5 x 5.25 case of 2000 \$72.98 or 3.5 x 9 for \$74.77, www.dentalprodx.com.

ORLAND Live & Practice in charming small town community. 1,000 sf w/ 2ops. Seller Retiring. \$160k (GC-472) WPS/800-641-4179.

FACT In dentistry your **HEALTH** is your **WEALTH**...
Is your income & family protected?!?! Call for a **FREE Disability Insurance Appraisal 855-346-9729 di4dds.com**.

N. COAST Endo Practice. 6 Ops, 5 plumbed 3,300 sq. ft. Digital, Microscopes, EndoVision. HSPPT-Jim Engel 925-330-2207-#CA214.

ASI self contained for sale \$4,200 we prefer selling both unit. They are in working condition. call 209-322-3429.

ASEPTICO AIRPAC Air Compressor AA-74SA-110, Like New, Original Cost \$900, Make Offer 855-772-7645 or janetm@hygiacare.com.

Sonora Dentist Looking for a full time associate dentist. Established patients waiting, high tech office. email sonoradentist@mlode.com or call 209-533-9630.

CENTRAL COAST/WINE COUNTRY (3) op comput G.P. & 1,900 sq ft free stand. bldg. for sale. Bldg. houses dental office & a residential unit. Live in unit or rent it out! Fee for Service pts. 2015 Projected Gross Collect \$280K p.t. Growth potential. Seller refers all specialities & does little advertising. Seller retiring but will assist with Transition. D&M Practice Sales 818.591.1401.

ENDO instruments New and like new many files, hand condensers/spreaders Will sell all very cheaply. (323) 851-6622.

WHY A DENTAL CPA? Call 714-259-0505 Wiederman & Chamberlain, CPA.

EpiPen Epinephrine Auto-Injector Adult 0.3mg. Expiration: July, 2016. MSRP \$550 for 2 pack. FOR SALE \$175 FOR ONE. gaw1177@gmail.com.

\$4995 American Manufactured Dry Vacuum System \$1000 Cash Rebate or 36 Month No Interest Financing OAC. Call (800) 423 - 5657 or visit DHPDENTAL.COM for more details.

"Pat, Thank you for speaking at the Western Conference last week. I attended your Thursday afternoon CE Class "Deal f the Year: \$6K of Advice for the Price of Admission". With my lease up this year, and purchasing a new building, I was all ears, and your advise was worth way more that the promised amount of \$6,000." SETH TAMBRINI, DDS. CALL TODAY 800-499-1474 WOOD & DELGADO www.dentalattorneys.com.

CONSUMER ALERT!

The Dental Trader

refuses to do business
with the following companies:

AMERICAN BUSINESS CARD

aka: Bizcard.com
(A CEG Company)
P.O. Box 15190
Scottsdale, AZ 85267
www.americanbusinesscard.com
Ph: 800-555-2234 Fax: 800-500-4506

PROFESSIONAL FINANCING INC.

Alexander Slepak
20371 Irvine Avenue, #100
Newport Beach, CA 92707
www.professionalfinancing.net
doctor@professionalfinancing.net
Ph: 323-272-3543 Fax: 480-948-0082

This notice is based on the advertisers' contractual lack of performance and/or legal action/court judgments.

If you have had a problem with these or any other Dental Trader advertiser, please send your formal complaint to:

The Dental Trader
Attn: Complaints
Post Office Box 2631
Capistrano Beach, CA 92624
Fax: 949-498-1198
Email: tradestaff@cox.net

Be sure to include any relevant documentation concerning your complaint

HANDS-ON Surgical Course

Surgical Extractions, Bone Grafting, and Implant Placement

Limited availability. Sign up today!

4 CE UNITS

- Learn comprehensive treatment planning.
- Learn to perform difficult extractions and proper bone regeneration techniques.
- Learn the surgical placement of dental implants on pig jaws.
- Learn implant prosthetic phase.
- Learn how to manage surgical and prosthetic complications.
- Increase case acceptance.

Hands-on Course Tuition:
Only \$499

Hands-on Course Includes:
4 CE Units, all surgical materials,
implants, and pig jaws.

COURSE DATES:

Saturday, December 19, 2015
Saturday, January 16, 2016
Saturday, March 12, 2016
Saturday, May 14, 2016
Saturday, September 17, 2016
Saturday, December 17, 2016



100% of the profits from the course are used to treat our veterans and neglected older adults living below the threshold of poverty.



This course is being conducted by a team of experienced board-certified oral surgeons, prosthodontists, and periodontists. It is led by Dr. Charles Zahedi who is faculty at the University of California, Los Angeles. Previously he was a full-time Associate Professor at the Department of Advanced Periodontics and Implant Surgery at Loma Linda University. He has been extensively involved with dental implants since 1990 and has trained hundreds of dentists around the world from Europe, Asia, South America, and the United States. Dr. Zahedi is the founder and clinical director of Dentists for Veterans and the Oral Disability Rescue. These non-profit organizations have initiated the first nationwide study on veterans and have been a pioneer in preventing abuse of older adults. Our mission is to bring about awareness of the importance of oral health care for every individual.

Call Now 888.871.0009

info@implantmentoring.com | www.implantmentoring.com | www.implantoutreach.com

©2015 Implant Outreach Inc. All rights reserved. Implant Outreach® is a registered service mark. Do not Quote, Cite, Use or Reproduce Without Written Permission of Implant Outreach Inc.

Buy it! Sell it! Trade it!!!

WANTED Current address of Kurt Conrad dba: Conrad Capital Kurt Conrad-Director of Professional Lending aka: Rep OZARKS CAPITAL FUNDING Last known address: 45751 Rancho Palمراس, Indian Wells, CA 92210 www.ocfl ink.com email: kurt.conrad@ocfl ink.com Ph: 949-300-2433 Fax: 949-759-0746. Please contact Bruce at The Dental Trader if you know the current whereabouts of this former advertiser. Thank you. 877 888 4237.

Handler Chuck/Changer w /Lathe Model 16BN. Never used. \$550. OBO 949-202-4420.

ROSEVILLE Facility Hesitate and you might miss out on this opportunity! 875 sf w/ 2 ops + 2 add'l. \$49.5k (EN-475) WPS/800-641-4179

DENTAL PRACTICES WANTED in Temecula, Murrieta, Corona 4 – 6 ops. Growth Potential, PPO/FFS. Sellers call Loc Pham, Broker at LCF Financial, Inc. BRE#01875780. (714)550-7494 or practice@lcfinc.com | LCFPracticeSales.com.

AirTechniques AT 2000 XR. \$1000 OBO. Last used 10/14. Manual/cleaning films incl. Year Unknown. Will Email Pix. 661-823-7644.

Wanted Dr. looking to rent space to see patients/build a practice. GP office in Hayward available immediately. Contact heritagedentalx2@gmail.com.

Intraoral Cameras with premium warranty and lifetime support on SALE NOW! See color flier in this issue for details.

COLLECTIBLE 1950s Ritter dental unit and chair for display or collector. Very good condition. Asking \$500. Any offer considered. cdentaljohn@aol.com.

Dental office for rent/sale in historic Jamestown. Great location on Main St. (2)ops plumbed. \$800/mo. (209)984-3035

NORTH OF SACRAMENTO 1,324 sq. ft. office w/4 Ops, Dentrix software, Pano. Owner worked 39 weeks 2014. HSPPT-Thomas Wagner 916-812-3255-#CA267.

DentiMax Dream Sensors. Try before you buy. Test our award winning sensor in the comfort of your own practice without any obligation. Call 1(800)397-6046.

Free Dentists Stool (\$325 Value) with the purchase of an Assistants Stool for \$450. 100's of Color Choice's. Made in USA Call (800) 423 - 5657 or visit DHPDENTAL.COM for more details.

Close office end Sept, everything must go 2 full op, office supply etc must see. Contact email or 5623283626.

Can't find what you're looking for? Call Bruce at The Dental Trader! I've been building a database of dental companies and resources for over three decades. If I can't help you locate it, it probably doesn't exist anymore. I'm here to help. 877 888 4237.

NEW Aseptic portable dental unit Self contained Irrigation and Evacuation System ADU-17X & Portable aseptic-110V ALU-29 Call (909)217-0814.

Taylor Liao Manager of Kings Two Dental Supply (City of Industry, CA)-What can I say about him? He's the lawyer we go to when we need a lawyer. Dr. Chester Jeng of Law Offices of Jeng and Associates is very personable and knowledgeable in dentistry and law. He's definitely a straight shooter, he tells you what you need to know and also what you probably do not want to hear. He's the one we go to if we need a lawyer. Call Jeng & Associates 714-858-0536.

Dental Instruments New or like new condensers/carvers for composites and amalgams. Explorers, perio probes, 5 only-perio scalers (323) 851-6622.

ASEPTICO CompriCart ADU-20B Delivery Unit with Fiber Optic Scaler. Like New, Original Cost \$2,690 Make Offer. 855-772-7645 or janetm@hygiacare.com.

Brand new Hereaus Dynamix 6650124(henry schein price 2423.79 before tax) asking 1900.00 call Dr. Tim 5623353665.

PRACTICE & BUILDING FOR SALE--LA MESA. 5 equipped Ops in 2700 sq.ft. Digital X-rays and Pan. SDPS: 760-599-7828.

GP/Implant Office for sale San Francisco Bay Area Retiring Owner Cell: 925-864-3713.

Chemiclave 5000 AT 2000 film processor, safe light, Foster model trimmer, workstation carts, all in good working condition. (909)910-1688.

FOLSOM History is alive here with tributes to the past! 1,600 sf w/ 3ops. \$225k (EG-479) WPS/800-641-4179.

Selling I-CAT FLX. Purchased new May, 2014 list price \$154,999 remaining warranty transferable. \$100,000 OBO Call (707)4670875.

Legal Tip Fictitious business names are not permitted as a dental corporation's name. Attorney Robert W. Olson, Jr., 805.963.1120, www.transdental.com.

Need a Blast from the Past? Find anything printed in an old edition instantly using the search engine on our Dental Trader Archives page at <http://thedentaltrader.com/archive.htm>.

HENRY SCHEIN®

PROFESSIONAL PRACTICE TRANSITIONS

Contact
one of our
experienced
Transition
Consultants



Dr. Lee Maddox
Lic. #01801165
(949) 675-5578
25 Years in Business



Dr. Thomas Wagner
Lic. #01418359
(916) 812-3255
40 Years in Business



Dr. Dennis Hoover
Lic. #123804
(209) 605-9039
36 Years in Business



Dr. Russell Okihara
License #01886221
(619) 694-7077
33 years in business



Jim Engel
License #01898522
(925) 330-2207
42 Years in Business

PRACTICE SALES • PARTNERSHIPS • MERGERS • VALUATIONS/APPRISALS • ASSOCIATESHIPS • CONTINUING EDUCATION

NORTHERN CALIFORNIA

BENICIA - General Dentistry - Practice and Building for sale of this well-established office in the beautiful waterside community of Benicia, our first State Capitol. 2014 GR of \$555,000 on 4 1/2 day week with 4 equipped treatment rooms in approx. 1545 sq. ft. Practice utilizes Open Dental software, Digital X-Ray, Digital Pan and Laser. Approx. 1300 active patients with 7-8 new patients per month. Owners are retiring from private practice and will help buyer with a smooth transition. #CA298 Jim Engel - 925-330-2207.

CALAVERAS COUNTY - General Dentistry - After 40 years practicing in this historic gold mining town and 26 years in its present location, the doctor is retiring. There are four operatories in 1,752 sq. ft. Practice features Dexis Digital X-Rays, Eaglesoft, Cerec unit and Pano. Average collections for the last 3 years has been \$450,000 / yr. #CA294-Dennis Hoover - 209-605-9039.

CASTRO VALLEY - General Dentistry - Practice & Building for sale. Approx. 1,800 sq. ft. with 3 fully equipped operatories, one additional plumbed but not equipped. 2014 Gross Receipts of \$373,000 on four day work week, three days of Hygiene. Stand-alone building on major freeway exit near shopping, restaurants, and other businesses. Owner is retiring after 38 years of practicing in this great community. #CA251 Jim Engel - 925-330-2207.

FOLSOM - General Dentistry - Located in well-designed, 2,420 sq. ft. office with 5 Ops, Shick Digital X-rays, Pano (Digital), 8 days hygiene/wk, and Carestream/Sofdent software. #CA235-Thomas Wagner - 916-812-3255.

FOLSOM - FACILITY ONLY - Well-designed, modern, fully equipped, 1,200 sq. ft. dental office with 3 Ops, digital x-rays, digital pan, computers & monitors in all ops, high & low speed handpieces, cavitrons, and Statim 5000. Nobel Vision TV, Danserau vacuum, and a new 2.5 hp compressor. Owner is willing to include about 400 HMO patients with the facility sale, if buyer is interested. #CA209-Thomas Wagner - 916-812-3255.

GREATER PITTSBURG AREA - PRICE REDUCED by \$122,000 - General Dentistry. Est. for over 35 years, owner retiring. 7 Ops in 2,324 sq. ft. with Dental Mate software, Intra-Oral camera, Pano, and Digital X-rays. 2014 Gross Receipts of \$848K with overhead under 70%. Building to be sold with Practice. #CA108 Thomas Wagner - 916-812-3255.

GREATER ROSEVILLE/ROCKLIN/LOOMIS - General Dentistry- Beautiful, vaulted ceiling 1,500 sq. ft. facility with 5 Ops (4 equipped). Fully digital, Dentrix G5, radiography with Dexis sensors and Optime plates systems. Well-equipped and highly-maintained. Greatly organized business. Have it all, live and work in a phenomenal family-oriented community. Seller refers out molar endo, ortho, O.S., and perio. Gross Receipts in 2014 was \$469K. Seller is retiring. #CA239 Thomas Wagner - 916-812-3255.

GREATER SACRAMENTO - General Dentistry - Well-designed 3,079 sq. ft. office (shared w/2nd dentist - separate practices) in professional building. 7 ops w/Digital X-ray, Pano, and Datacon software. 2014 Gross Receipts of \$930K w/low overhead. Owner retiring after 35+ years in same location. #CA140- Thomas Wagner - 916-812-3255.

GREATER SACRAMENTO - General Dentistry - Northern Sacramento Area practice, located in same location for 15 years. 6 Ops in approx. 2,100 sq. ft. with Dentrix software, fiber-optics, and X-rays in every op. 2014 combined Gross Receipts of \$1.1M. #CA237- Thomas Wagner - 916-812-3255.

GREATER SAN JOSE AREA - Periodontal Practice - Receipts for fiscal year ending in Sept. 2014 were \$1.3M. Practice has been the same location for 28 years in a medical-dental complex on a busy thoroughfare. 5 Ops with the potential for 2 more. Equipped with Digital X-rays, Pano, Cone Beam, Laser, and Intra-Oral. Practice averages 35 new patients per month. Owner would like to work back 1-2 days per week. #CA219-Dennis Hoover - 209-605-9039.

LIVERMORE - General Dentistry - Practice & Building sold together: Beautiful. Professionally designed office in the center of this Wine Country community. 4 completely equipped treatment rooms in approx. 1100 sq. ft. Digital Pan, Digital X-Ray and Laser. Office utilizes Dentrix software and digital sensors with 6 computer workstations. 2014 GR of \$740,000 with adjusted net over 46% and growing in 2015. Owner is retiring from private practice and will help buyer through a smooth transition. #CA300 Jim Engel - 925-330-2207.

MARIN COUNTY - General Dentistry- This rare Mill Valley charmer boasts 2013 Gross Receipts of \$502K on 3 doctor days per week. Established for over 10 years utilizing Dentrix software, Digital X-ray, and Intra-Oral Camera. 3 equipped Ops and 1 additional plumbed in 1,260 sq. ft. Great location on a busy thoroughfare near shopping, schools, and senior retirement center. Owner has another practice outside the area so this is priced to sell in this idyllic family setting. #CA224-Jim Engel - 925-330-2207.

MARIN COUNTY - General Dentistry- This great location in Central Marin boasts great views of Corte Madera Creek from each of its three treatment rooms. 2014 Gross Revenues of \$315,000 are down for its historical past, but priced right for an energetic buyer ready to follow this well-known esthetic master. Eaglesoft Software, Schick Digital Sensors and Paperless Charts. Average age of Equipment is 10 years. Owner is retiring after 36 years of private practice and will help buyer with the transition. #CA286-Jim Engel - 925-330-2207.

MARIN COUNTY - NEW LISTING - This Central Marin Village office offers approx. 1250 sq. ft. with 3 fully equipped treatment rooms. This downtown shopping area location has housed a dental practice for over 70 years, 38 with the present owner. Fee for service 2014 GR of \$370,000 and on pace for same in 2015. Seller owns the building and will offer buyer a favorable lease and help with a smooth transition. Owner is retiring from private practice. #CA302 Jim Engel - 925-330-2207.

MILLBRAE - General Dentistry- Beautiful, professionally designed office boasting 5 fully equipped treatment rooms in approx. 1500 sq. ft. 2014 Gross Revenue of \$670,000 with Eaglesoft PMS, Digital Pan, Digital X-Ray and state of the art equipment. Office fronts busiest street on the Peninsula and offers great exposure for continued growth. Near BART, Cal Train and 10 minutes to SFO. Owner retiring to pursue other interests. #CA262-Jim Engel - 925-330-2207.

NORTH COAST - Endodontic Practice - Humboldt County: Well-established, high performing practice boasts 6 Ops (5 equipped) in 3,300 sq. ft. with Digital X-ray, Microscopes, and EndoVision software. Average age of equipment is 10 years. Very low overhead with excellent referral base. Owner will help buyer with transition period as needed. Owner retiring after 38 years in the community. #CA214-Jim Engel - 925-330-2207.

NORTHERN CALIFORNIA OFFICE
1.800.519.3458



www.henryscheinppt.com

SOUTHERN CALIFORNIA OFFICE
1.888.685.8100

DENTAL PRACTICE BROKERAGE

Making your transition a reality.



Kerri McCullough
License #01382259
(949) 566-3056
35 Years in Business



Mario Molina
License #01423762
(949) 675-5578
35 Years in Business



Jaci Hardison
License #01927713
(949) 675-5578
26 Years in Business



Steve Caudill
License #00411157
(951) 314-5542
25 years in Business



Tinh Tran
License #01863784
(949) 675-5578
11 Years in Business

More than
75 Years of
Experience!

PRACTICE SALES • PARTNERSHIPS • MERGERS • VALUATIONS/APPRISALS • ASSOCIATESHIPS • CONTINUING EDUCATION

NORTH EAST OF SACRAMENTO – General Practice: 2,500 sq. ft. office with 7 Ops in seller-owned professional condo. Equipped with intra-oral, digital x-ray, and Eaglesoft software. Practice has been in this location for almost 40 years, 2014 GR of \$1.5M. Seller retiring. #CA268-Thomas Wagner - 916-812-3255.

NORTH OF SACRAMENTO – General Practice: 1,750 sq. ft. leased office in a larger professional office complex with 4 operatories. Intra-oral Camera, Digital X-ray, Imaging System, Pano, Laser, CAD-CAM, and Dentrrix software. 2014 GR of \$1M on 4 day week. Practice has been established at current location for over 20 years. #CA260-Thomas Wagner - 916-812-3255.

NORTH OF SACRAMENTO – General Practice: Practice located in highly-desirable location, office has 1,324 sq. ft. with 4 Ops. Owner worked 39 weeks in 2014. Dentrrix software, pano, 5 days of hygiene per week. Owner retiring #CA267-Thomas Wagner - 916-812-3255.

NORTHERN CALIFORNIA – Periodontal Partnership Opportunity: One of two partners is retiring from a long-est., very successful Perio Practice. 1,500 sq. ft., 6 Ops, and Dentrrix software. Owner financing with acceptable down payment. Sale to new partner is subject to approval by current partner. #CA168-Thomas Wagner - 916-812-3255.

NORTHERN CALIFORNIA – Endodontic Practice: Well-est. satellite endodontic practice with 3 ops (1 additional plumbed) in 1,200 sq. ft. Two microscopes, Digital. 2014 Gross Receipts \$280K+. #CA158-Thomas Wagner - 916-812-3255.

NORTH SACRAMENTO – General Practice: This PPO practice is in a leased space with less than 1,000 sq. ft. and three operatories. Practice features 2 days of hygiene, digital x-rays, & Easy Dental software. Owner is relocating. #CA266-Thomas Wagner - 916-812-3255.

OAKLAND – General Dentistry- Downtown Oakland Historic Building boasts partial views of Lake Merit. Approx. 1500 sq. ft. with 4 completely furnished treatment rooms, Dentrrix Software, Dexis Digital X-Ray and nearly 80 new patients per month. 2014 GR of \$869,000 with adjusted net over \$370,000 on 5 day week. PPO/HMO/FFS patients with continued growth over 20% in 2015. Owner is downsizing. #CA293-Jim Engel - 925-330-2207.

OROVILLE – General Practice. This 1000 sq. ft office was completely remodeled in 2010. It features Dentrrix and Dexis software with 9 computer stations, Digital Pan and X-rays, Laser, and Intraoral Camera. 2014 gross was \$512K with 3 days of hygiene. Owner is retiring after 36 years in Oroville. #CA287-Dennis Hoover - 209-605-9039.

OROVILLE – General Practice. This 3 op office is ideal for a satellite or startup practice. Most of the equipment is less than 5 years old and the office is looks new having been recently remodeled. Owner is retiring after 30 years in Oroville and 16 years in this location. #CA288-Dennis Hoover - 209-605-9039.

OAKLAND - General Dentistry: Piedmont District – Well-established downtown charmer w/ Gross Receipts of \$453K. 3 treatment rooms in shared office totaling 1,000 sq. ft.. Off-street parking w/5 days of hygiene, 8 new patients per month. Owner retiring after 27 years at this location. #CA217 Jim Engel - 925-330-2207.

PITTSBURG – General Dentistry- Well-est. practice on city's busiest thoroughfare. 3 year avg. Gross Receipts of \$236K. 60% overhead. 5 ops in 1,400 sq. ft. with Pano, Fiber Optics. 12 NP/ mo. and very favorable rent. Avg. age of equip. is 15 years. Owner is retiring. #CA133- Jim Engel - 925-330-2207.

PINOLE – Endodontic Practice - This professionally designed Endo office has served the community for over 36 years. Gross Revenue of \$672K, with adjusted net over \$300K on 4 days per week. 4 completely furnished treatment rooms with PBS Endo Software, Digital X-Ray and Microscopes and packaged tastefully in approx. 1200 sq. ft. Average age of the equipment is 10 years with other new items. Owner is retiring but will help buyer with introductions to all key referrals. Office space ownership is also available. #CA284-Jim Engel - 925-330-2207.

PLEASANTON – Facility Only Sale: Former Endo office but also perfect for a GP startup in this high-demand neighborhood. 2 fully equipped Ops, Computers Microscope, 3rd Op plumbed and partially equipped. 975 sq. ft. in a Professional Complex with Perio, Ortho, and GPs. Below market rent and ready to move in. Call for photos and more details on this great location with almost new equipment! #CA195-Jim Engel - 925-330-2207.

SACRAMENTO – General Practice: 3 equipped ops (1 additional plumbed) in 1,320 office equipped with Carestream software, Dexis Digital X-ray, Intraoral, Imaging System. Practice established 15+ years, 4 days hygiene per week, 2014 GR \$434K. #CA296-Thomas Wagner - 916-812-3255.

SACRAMENTO – General Practice: 2,400 sq. ft. practice in stand-alone professional building with 7 equipped Ops, 1 additional plumbed. Equipped with Digital-Doc Intra-Oral, Schick Digital X-ray, Imaging system, patient education software, Pano, Softdent software with equipment updated within the last 2 years and new flooring installed throughout. 2014 Gross Receipts were \$626K+. Owner retiring. #CA250-Thomas Wagner - 916-812-3255.

SACRAMENTO – General Dentistry Practice and Condominium. 1,300 sq. ft. office in professional building with 4 Ops. Eaglesoft software and fiber optics. 2014 GR of \$650K. Owner retiring. #CA261-Thomas Wagner - 916-812-3255.

SACRAMENTO – General Practice: Leased 1,684 sq. ft. open concept pediatric office in a professional building with 6 equipped stations and 2 additional plumbed. Averaging 16 new patients per month, \$590K GR in 2014. Seller retiring. #CA269-Thomas Wagner - 916-812-3255.

SACRAMENTO – General Practice: Russian-speaking general dentistry practice. Leased 1,500 sq. ft. office with 4 Operatories, equipped with Intra Oral camera, Digital X-ray, Imaging System, Pano, Biolase, 3D CBCT, and CAD-CAM. All equipment is less than 2 years old, practice was started 1.5 years ago with \$1M Gross Receipts over the first 12 months. 2015 YTD Gross Receipts as of October is \$1.1M. #CA290-Thomas Wagner - 916-812-3255.

SACRAMENTO – General Practice: 2,500 sq. ft. office w/6 equipped ops, 1 additional plumbed. Dentrrix software, Digital X-ray, Intra-oral, Pano. 2014 GR \$788K. Practice established for over 30 years. Lease ends 2/2016 and will not be renewed. Seller would like to move this practice into another practice and work-back 3 days/week. #CA297-Thomas Wagner - 916-812-3255.

NORTHERN CALIFORNIA OFFICE
1.800.519.3458



www.henryscheinppt.com

SOUTHERN CALIFORNIA OFFICE
1.888.685.8100

HENRY SCHEIN®

PROFESSIONAL PRACTICE TRANSITIONS

DENTAL PRACTICE BROKERAGE

Making your transition a reality.

PRACTICE SALES • PARTNERSHIPS • MERGERS • VALUATIONS/APPRISALS • ASSOCIATESHIPS • CONTINUING EDUCATION

SAN FRANCISCO: FINANCIAL DISTRICT- Periodontal Practice and Condo Unit. This four op office in downtown San Francisco has gross receipts of \$714,000 and a net income of \$363,000 in 2014. The seller is also selling his condo unit occupied by his practice. The condo unit has 1,160 sq. feet with a northwest exposure and beautiful view. Excellent opportunity to work and own your own office space in the downtown area of one of the world's most vibrant cities. #CA274 - Dennis Hoover - 209-605-9039.

SANTA MARIA – This Central Coast beauty boasts 42 years in the community, 16 years at current location. 4 Ops in 1,500 sq. ft. Easy Dental software, Dexis Digital X-ray, and Intra-oral cameras. 2013 Gross Receipts of \$523K in 180 Dr. days. 5 days of hygiene. Close to hospital, Comm. College, and freeway. Seller owns the suite and is retiring. #CA166- Jim Engel - 925-330-2207.

SANTA ROSA – This 3 Op office is part of a larger complex, owner selling interest in building. 4 days of hygiene seeing 10-12 patients per day, booked 6 months in advance. 2013 Gross Receipts were \$542K with \$182K Adjusted Net. Practice was started by present owner in 1968, owner is retiring. #CA200-Dennis Hoover - 209-605-9039.

SOLANO COUNTY – General Practice: Leased 1,350 sq. ft. office in office complex with 4 ops, Intra-Oral, Gendex Digital X-ray, Imaging System, Pano, and Dentrax software. 2014 Gross Receipts of \$869K on 30 hour/week. Practice established for 18 years, owner retiring. #CA246-Thomas Wagner - 916-812-3255.

SONOMA – General Practice: Wine County Beauty boasts a professionally designed, stand-alone 2000 sq. ft. building with 4 fully equipped treatment rooms, plenty of light and nearly every dental technology available including Digital X-Rays, Lasers, CAD/CAM & more. 2014 Gross revenue of \$675,000 on a 3 day work week. Practice started over 50 years ago, present owner has practiced for 26 years, 12 years at this location. Owner is relocating out of state and owns the building. #CA270 - Jim Engel - 925-330-2207.

SOUTHERN SACRAMENTO COUNTY – General Practice: Condo office with 1,380 sq. ft. and 4 Ops, equipped with Intra-Oral, Dexis Digital X-ray, Pano, Laser, and Easy Dental software. 2014 Gross Receipts were \$581K, practice established for 18 years, owner retiring. #CA249 -Thomas Wagner - 916-812-3255.

WALNUT CREEK – Prosthodontic Practice with 3 Ops, fully equipped, near a retirement community. Doctor is retiring after 28 years in the same location. Practice had over \$530K in Gross Receipts in 2012. #CAM540 - Jim Engel - 925-330-2207.

YOLO COUNTY – NEW LISTING - Yolo County: Opportunity for energetic Pediatric Dentist to become established in quickly growing community northwest of Sacramento. Good opportunity to expand current practice and/or use as a satellite practice. Two equipped operatories in approximately 1,000 sq. ft. office with Intra-oral camera and Open Dental software. 2014 GR of \$245K. #CA301-Thomas Wagner - 916-812-3255.

CENTRAL CALIFORNIA

CENTRAL COAST – General Practice in the Central Coast area. 31 years of goodwill. 6 Ops, 8 days of hyg/week. 2013 Gross Receipts of \$2.3M and Adj. Net of \$840K. Dentrax, Digital, Paperless, Intra-Oral Camera, Laser. #CA208-Kerri McCullough - 949-300-0312.

FRESNO – General Dentistry. This 1,739 sq. ft. office has 4 Ops with 6 days of hyg. Gross Receipts have averaged \$760K per year with low 61% overhead. General X-rays & Scanner, Soft Tissue Laser, Intra-Oral, Digital Pan, and Cerec CAD/CAM. Owner is retiring after 31 years in the same location. #CA202-Dennis Hoover - 209-605-9039.

KINGS COUNTY – This retiring dentist is in the rural community of Kings County, CA. Practice has been established for 50 years in the area with 4 Operatories, intra-oral camera, Panographic x-ray unit and completely furnished. Gross Receipts for 2014 were \$246K. This would be a great location to relocate or open a second office. #CA265 - Steve Caudill - 951-314-5542.

MADERA- General Dentistry – Building and Dental Practice. This beautiful 6 operator, 3000 sq. ft. office is located in a stand-alone building. 2014 receipts were \$850,000. Dentrax and Dexis software, Panographic X-ray. 1,400 active patients with 8 days of hygiene/week. Practice started by owner in 1971. #CA289-Dennis Hoover - 209-605-9039.

PASO ROBLES – General Dentistry. Central Coast Wine Country beauty features a modern, professionally designed GP practice on one of the busiest thoroughfares. Digital X-Ray, Softdent Practice Management and 8 computer workstations. 4 fully equipped treatment rooms with 2014 GR of \$573,000 on 192 days per year. 4 days of hygiene per week & 6-7 new patients per month. Owner retiring after 38 years and will assist with transition. This rapidly growing community offers a great opportunity for a new buyer! #CA275 - Jim Engel - 925-330-2207.

PORTERVILLE – General Dentistry with 6 Ops in a 2,600 sq. ft. suite located in a retail center. 2014 Gross Receipts of \$555K. 7 year new equipment, intra-oral camera, Pano, PracticeWeb. #CA223-Steve Caudill - 951-314-5542.

TULARE – General Dentistry. This beautiful 5 operator office is located in a 2,300 sq.ft., highly-visible, free-standing building. In 2014 the practice grossed \$1,746,000 in collections. The doctor offers treatment for sleep apnea, cosmetic dentistry, including full mouth reconstructions, and Invisalign as part of his general dentistry services. There are 10 days of hygiene. Owner moving out of state. Call for information. #CA273-Dennis Hoover - 209-605-9039.

TUOLUMNE COUNTY - General Dentistry Practice & Building. Gross Receipts averaged over \$1M in 2013, 2012, & 2011 with just 59% overhead, and 8 days of hygiene. There are 6 Ops in approx. 2,000 sq. ft. Patient average age is 3-4 years. The building is well-maintained with storage and upscale interior décor. 45 minutes from population centers with 200K+ people. #CA199-Dennis Hoover - 209-605-9039.

SOUTHERN CALIFORNIA

ANAHEIM HILLS – General Dentistry, 4 Ops, Established 34 years. Dentrax. 6 days of hygiene per week, long-term staff. #CA279 - In Escrow. Kerri McCullough - 949-300-0312.

BAKERSFIELD – General Dentistry practice with 4 operatories features Dentrax, Dexis digital x-rays, and a Pano. This is a PPO/FFS practice. #CA299- In Escrow. Thinkh Tran – 949-533-8308.

BALDWIN PARK – General Dentistry - 5 Ops, 4 Equipped in a 1,500 sq. ft. suite. \$276K GR in 2014. Seller is relocating out of state. #CA176-Kerri McCullough - 949-300-0312.

BANNING – General Dentistry - 6 Ops in 1,873 sq. ft. Digital x-rays, EagleSoft, and is paperless. 8 days of hygiene per week. 2014 GR of over \$1.4MM. #CA183- In Escrow. Steve Caudill - 951-314-5542.

BEVERLY HILLS – General Dentist est. for 20 years, moved 2 years ago to a boutique ofc. 2 Ops. 1 equipped. OpenDental, Digital, paperless. 2014 GR \$120K on 3 days/week. FFS & PPO. #CA215-Mario Molina - 323-974-4592.

BEVERLY HILLS – General Dentistry Practice. 5 Ops in 1,500 sq. ft. EagleSoft, Digital, CEREC, ~7 yr. new equipment. 4 days hyg/week. 2014 GR \$1.09M #CA210- In Escrow. Kerri McCullough - 949-300-0312.

CARSON – General Dentistry practice. 3 Ops, EagleSoft, paperless, digital, Pano. All equipment is <3 years old. 2014 GR \$143K, room to grow. #CA280 - Kerri McCullough - 949-300-0312.

CYPRESS – General Dentistry. 5 Ops, Est. for 35 years. 7 days of Hyg/week, most specialty work referred. 2014 GR \$948K with \$426K Ad. Net. #CA257 - In Escrow. Kerri McCullough - 949-300-0312.

GREATER LOS ANGELES AREA - Periodontal Practice-5 Ops, Dentrax, Digital X-Rays, Laser, Intra-Oral Camera. Great referral base, 34 Years of Goodwill. #CA173-Kerri McCullough - 949-300-0312.

NORTHERN CALIFORNIA OFFICE
1.800.519.3458



www.henryscheinppt.com

SOUTHERN CALIFORNIA OFFICE
1.888.685.8100

Henry Schein Corporate Broker #01230466

Buy it! Sell it! Trade it!!!

HENRY SCHEIN®

PROFESSIONAL PRACTICE TRANSITIONS

DENTAL PRACTICE BROKERAGE

Making your transition a reality.

PRACTICE SALES • PARTNERSHIPS • MERGERS • VALUATIONS/APPRISALS • ASSOCIATESHIPS • CONTINUING EDUCATION

HACIENDA HEIGHTS – NEW LISTING – General Dentistry. 5 Ops, 3 Equipped, retail center, Intra-oral camera, Digital Pano, and <10 year old equip. Long-term staff, 20 NP/mo. Practice accepts some PPO plans, no HMO. #CA295 - Steve Caudill - 951-314-5542.

HUNTINGTON BEACH – General Dentistry. 5 Ops, Est. for 28 years. Digital x-rays, Pano, Laser, Intra-Oral Camera, 12 days of hyg./wk. 2014 GR of \$1.1M+. #CA263-Kerri McCullough - 949-300-0312.

HUNTINGTON BEACH – General Dentistry Practice. 3 Ops, 2 Equipped. Established 18 years near residential, shopping, and freeway. 2014 GR \$396K on 4 days/week. PPO/FFS. #CA277 - Kerri McCullough - 949-300-0312.

INLAND EMPIRE – Endodontic Practice – This 4 Op practice features 8 year new equipment, digital x-rays, and Cone Beam CT. 60+ years of goodwill and is near freeway. 2014 GR of \$739K on 4 days/week with low overhead. #CA281-Steve Caudill - 951-314-5542.

INLAND EMPIRE – General Dentistry Practice with 7 Ops, Dentrrix, digital, Pano. 30 years of goodwill. 4½ days of hygiene per week. PPO and 2 HMO plans accepted. #CA283 – In Escrow. Kerri McCullough - 949-300-0312.

INLAND EMPIRE – General Dentistry Practice with 4 Ops, Intra-Oral Camera, Digital X-rays, and Pano. 2014 Gross Receipts of \$534K and Adjusted Net Income of \$196K. Seller is retiring. #CA285 – Thinh Tran – 949-533-8308.

LAGUNA BEACH – NEW LISTING – General Dentistry. 5 Ops, 3 Equipped, great location! \$503K GR in 2014. For more information, call Thinh Tran – #CA304 - 949-533-8308.

LOS ANGELES – General Dentistry. 6 Ops, 5 Equipped, est. 50+ years, in current location for 29. SoftDent, Digital, Intra-Oral Camera. 2014 GR \$591K. #CA255- Kerri McCullough - 949-300-0312.

LOS ANGELES – Endodontic Practice. 4 Ops. Est. over 30 years. Easy Dental and a Cone Beam. 2014 GR \$360K on 21 hours per week. #CA259- Kerri McCullough - 949-300-0312.

PALM DESERT – General Dentistry practice with 5 Ops, est. for 32 years. 18 NP/mo, 6 days of hyg./wk. 2014 GR of \$842K and \$339K Adj. Net. #CA245 – Kerri McCullough - 949-300-0312.

PASADENA AREA – NEW LISTING – General Dentistry practice with 3 Ops, Dentrrix, Dexis, Laser, and CEREC. Established 50+ years. Building also for sale with practice. #CA282-Kerri McCullough – 949-300-0312.

PICO RIVERA – General Dentistry. 6 Ops, est. since 1960. DentiSoft Intra-Oral Camera, Pano. Practice has 4½ days/Hyg. per week. 2014 GR \$690K. #CA258-Thinh Tran - 949-533-8308.

SAN GABRIEL VALLEY – NEW LISTING – General Dentistry. 4 Ops, 50+ years in the community. 2014 GR of \$159K, room to grow. PPO/DentiCal are taken in this practice. Thinh Tran – 949-533-8308.

SANTA BARBARA – NEW LISTING – General Dentistry. 4 Ops, established for 40+ years. Long-term staff and 8 days hyg./wk. FFS/Delta Premier. 2014 GR of \$827K. #CA291-Kerri McCullough – 949-300-0312.

SOUTH ORANGE COUNTY – Pediatric Dentistry. 4 Ops, 1 year new equipment, OpenDental, Digital X-Rays, and Pano. \$236K GR with room to grow. #CA222-Thinh Tran - 949-533-8308.

SOUTH PASADENA – General Dentistry Practice with 4 Ops, 3 equipped, paperless, digital, Dentrrix, Laser. 37+ years of goodwill, 4 days of hyg./week. 2014 GR of \$856K with \$271K Adj. Net. #CA244- In Escrow. Thinh Tran - 949-533-8308.

UPLAND – General Dentistry. 4 Ops, 3 Equipped, est. 25+ years. Open Dental, Digital X-Rays, Intra-Oral Camera. #CA254- Kerri McCullough - 949-300-0312.

VICTORVILLE – General Dentistry - 3 Ops plus 3 plumbed for expansion, 2,150 sq. ft., SoftDent, 2014 GR of \$273K, Est. 34 years. #CA149-Kerri McCullough - 949-300-0312.

WEST HOLLYWOOD – PRICE REDUCED General Dentistry – 4 Ops, Prof. Building, 9 years of goodwill, Intra-Oral Camera, Digital, Laser. Equipment avg. age is 5 years old, 2014 GR of \$571K with 221K Adj. Net. #CA212-Kerri McCullough - 949-300-0312.

WEST LOS ANGELES – General Dentistry. 4 Ops, newly built-out high-rise on LA's west side. 50 years of goodwill. FFS, Easy Dental, digital x-rays. 2014 GR of \$651K. #CA226- Kerri McCullough - 949-300-0312.

WHITTIER – General Dentistry - 4 Ops, 3 equipped, Dentrrix, Dexis, est. for 50+ years on a main street.. Most specialty work is referred out. 2014 GR \$217K. #CA276 - Kerri McCullough - 949-300-0312.

SAN DIEGO

CHULA VISTA – PRICE REDUCED! General Dentistry- Est. 50 years ago, seller acquired 35 years ago. 4 Ops, 3 1/2 days of hygiene, Dentrrix Software. \$493K 2013 GR, seller is retiring. #CA109-Russ Okihara - 619-694-7077.

CHULA VISTA EAST – NEW LISTING – General Dentistry, 3 Ops with 2 days of hygiene per week. #CA302 - Russell Okihara - 619-694-7077.

DOWNTOWN SAN DIEGO – Leasehold sale: Modern and Chic downtown office in a prime location. 3 Ops, with room for expansion. #CA232-Russell Okihara - 619-694-7077.

ESCONDIDO – NEW LISTING – 4 Ops, 3 Chairs, Central Escondido. Doctor is retiring. Excellent opportunity to merge or grow. Looking for a quick sale. #CA292 Russell Okihara – 619-694-7077.

LA JOLLA – NEW LISTING - Quality driven General Practice, 3 Ops, FFS, Delta Premier, PT Hygienist, 2014 Revenues: \$559K, Dentist Retiring. #CA278 - Russell Okihara - 619-694-7077.

NORTH COUNTY COASTAL – General Dentistry. FFS/PPO. 3 Ops. Dentrrix. Digital X-Rays. 2014 GR of \$350K with \$228K Adj. Net. #CA253-Russell Okihara - 619-694-7077.

NORTH COUNTY INLAND – Highly-regarded General Dental Practice. FFS/PPO. 6 Ops in a beautiful, free-standing building. Opportunity for property ownership. #CA271- In Escrow. Russell Okihara - 619-694-7077.

SAN DIEGO – 3-Ops, with the dentist utilizing 2-ops. Small, quality boutique location. #CA161 - Russell Okihara - 619-694-7077.

SANTEE – General Dentistry. PPO/FFS office, 6 Ops, retail center with great anchors, Dentrrix and Digital. \$855K GR in 2014. 7 days of hyg./week, and long-term staff. #CA228 - Russell Okihara - 619-694-7077.

SOUTH BAY AREA, SAN DIEGO – PRICE REDUCED - General Dentistry, 3 Ops and 4 days of hyg./week. Dentrrix and Digital Pano, PPO and FFS with 2014 Projected Gross Receipts of \$562K. #CA206-Russell Okihara - 619-694-7077.

UPCOMING LISTINGS: SANTEE, CENTRAL SAN DIEGO and SOUTH BAY SAN DIEGO: PRACTICE AND BUILDING.

OUTSIDE OF CALIFORNIA

MAUI, HAWAII – NEW LISTING – General Dentistry. 7 Ops, 5 equipped. Lots of Goodwill, Computerized, FFS/PPO with a Modern design and CEREC. Excellent Location in Central Maui. 2014 GR over \$1.4MM. #HI101-Russell Okihara – 619-694-7077.

OAHU, HAWAII – NEW LISTING - Modern General Dentistry Practice with 3 Ops. Practice is computerized with Dentrrix, and digital X-rays. FFS/PPO, excellent opportunity. #HI100-Russell Okihara – 619-694-7077.

OAHU, HAWAII – NEW LISTING – General Dentistry practice with 3 Operatories. Practice utilizes Dentrrix, Dexis Digital X-rays, located in a shopping center. Established for 28 years, on most major PPOs. 2014 GR over \$360K. #HI102-Russell Okihara – 619-694-7077.

NORTHERN CALIFORNIA OFFICE
1.800.519.3458



www.henryscheinppt.com

SOUTHERN CALIFORNIA OFFICE
1.888.685.8100

AND THE AWARD GOES TO...



AWARD WINNING END OF THE YEAR SPECIAL



Call (800) 397-6046

Sensors starting as low as

\$3,999

FREE Installation and FREE Set Up
Offer Expires December 31, 2015



Buy it! Sell it! Trade it!!!

*****GP** 14 yrs+ exp offers: Implants, Bone Grafting, Extractions, & RCTs in your Bay Area office. Bring own instruments-materials. Flexible schedule. Bilingual English/Spanish. Why refer out, when you can keep the work and fees in-house?? (415) 895-0477 bayareadds1@gmail.com.

SANTA ANA Absentee owned (6) op fully eq't'd G.P. for sale. First floor street front location on a main thoroughfare. Exposure/visibility/signage. Cash/Ins/PPO pts. No HMO & no Denti-Cal. Computerized & Pano eq't'd. 2014 Gross Collect. of \$529K+ on a (3½) to (4) day Associate run week. D&M Practice Sales 818.591.1401.

RDA COURSES Coronal Polishing, Radiation Safety, Infection Control, BLS/CPR. CEUs \$19 Online: 2 Hr Infection Control, Dental Practice Act.(888) 988-2364 www.ADMInstitute.com info@adminstitute.com.

Mineralized Cortical bone 250-1000um Lowest pricing anywhere great for extractions \$22.00 per .25cc www.denatalprodx.com.

COASTAL OC General Practice for Sale, Asking \$385K, for more details contact Brooke at 714-259-0501.

SARATOGA Facility 2 fully equipped ops & room for 1 add'l w 1,178 sf. Move-In Ready \$150k (DG-499) WPS/800-641-4179.

NORTH OF SACRAMENTO 1,750 sq. ft. w/4 Ops. Intra-Oral, Digital X-ray, Pano, Laser, CAD-CAM, Dentrix. 2014 GR \$1M. HSPPT-Thomas Wagner 916-812-3255-#CA260.

Learn Ortho!! Your Office, Your Patients. Be mentored by an experienced and caring orthodontist. Call Kathleen. 626.590.9327.

FRESNO General Dental Practice & Building FOR SALE contact Brooke at 714-259-0501 for more details.

Our 9th Annual Dental Skills Series in San Jose includes an Endo Lecture and an 8 CE Intro to Dental Sleep Medicine...only \$299 and 15 CE's! Visit www.xcelseminars.com for info.

Pursuing ownership? Live Oak Bank can finance your dental practice with customized loan terms and quick credit approvals. 877.890.5867 www.liveoakbank.com/healthcare.

Dental Xray duplicator machine \$88 OBO 3109805265.

Practice Management Software 10% off any Practice Management purchase. Offer expires December 31, 2015. Call 1 (800)397-6046.



TIMOTHY GIROUX
DDS/BROKER

ASK THE BROKER

As the Year Comes to a Close...

As we approach the end of the year, interestingly enough, it is still a "seller's market" out there. Having said that, practices in the smaller, rural areas still take *more* time to sell and "facility-only opportunities without patients" are not moving as well as they had in the pre-economic shake-up, even in the larger urban markets. At some point in the next few years, hopefully sooner than later, we do expect a large increase of inventory as the baby boomers who graduated in the late 70's and early 80's will finally retire. I believe we are just starting to see a more normalized market and sellers who have been hanging on are finally starting to decide to hang up their drills.

Here is my year end advice for Sellers

If your practice is currently on the market or you are contemplating selling your practice next year, *finish the year strong!!* Lenders and Buyers value your practice almost exclusively on the most current year-end P&L. Try *not* to take too much time away from the office until January. Make all of your December bank deposits on time and try to have them posted *before* January, as opposed to some accountant's advice for you to wait until January so that the tax burden is delayed for a year. If you are currently in contract, most accountants will again advise their sellers to close in January. If you are thinking of selling next year, begin the process to put your practice in tip-top condition with strong financials and "ready to market curb appeal" in mid-to-late January, which is traditionally the busiest time of the year for buyers coming into the market!

Here is my year end advice to Buyers

If you are frustrated searching for the right opportunity, we are expecting a healthy surge in listings and our inventory sometime soon. I expect that this activity will continue to increase. Sellers who have been holding on may decide that it is finally time to retire next year as they probably realize that taxes and expenses will only increase in the future. Their investment portfolios should have rebounded from the 2008 crisis and hopefully they can now consider retirement on their own terms!

Again, I wish you much success and continued prosperity for the years ahead and a safe and happy holiday season with the people you care about.

Timothy Giroux, DDS owns Western Practice Sales and is a member of the nationally recognized dental organization, ADS Transitions.

Questions?

Contact Dr Giroux at wps@succeed.net or 800.641.4179



C P A D D S
Wiederman & Potter
 P R E M I U M P R A C T I C E S A L E S

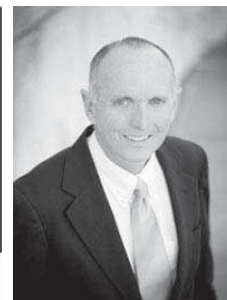

YOUR BRIDGE TO A SUCCESSFUL TRANSITION

Art Wiederman, CPA, CFP
 Broker #01511095

1415 Warner Ave., Suite C ~ Tustin, CA 92780
 714.259.0501 ~ 714.259.0406 f info@wppps.com ~ wppps.com

Phil Potter, DDS, FAGD
 Broker #01780656

Premium Practice Listings

★ North Central Los Angeles #1100 ★

Restorative cash fee-for-service practice, contemporary suite/ all digital, 2015
 Projected revenues over \$770,000
Asking \$575,000

Los Angeles Area PERIO #1090

Outstanding periodontal practice in a
 premier location, five (5) treatment
 rooms, 1,500 sq ft, seller retiring,
 projected gross for 2015 over \$1 million.
Asking \$595,000

South Orange County #1099

Restorative fee-for-service practice, five
 (5) equipped treatment rooms,
 contemporary 2,000 sq ft., digital x-ray,
 lasers, intraoral cameras, 37 years of
 goodwill, seller will work-back,
 2014 Gross revenues \$1,426,236
Asking \$1,300,000

Placer County #1073

Fee-for-Service
 Restorative Practice
 Beautiful Contemporary Office in
 Great Location
 All Digital with Cone Beam
 2014 Gross Revenues \$1,629,000

Asking Price: \$1,198,000

PERIODONTAL Practice #1092

San Francisco Bay Area, all digital,
 annual profit over 55%,
 2014 Gross over \$1,600,000

Asking \$700,000

Sonoma County #1101

General Dental Practice and Building
 2415 Square Foot Digital Suite
 Eight Days/Week Hygiene
 Projected 2015 Gross \$1,603,000
Practice asking Price \$1,150,000

North Los Angeles County #1097

General esthetic and restorative practice,
 turn-key, 10 treatment rooms, all digital,
 seller retiring. 2014 revenues \$1,708,000

Asking \$1,275,000

Fresno County #1091

Outstanding general dental practice and
 dental building for sale, approx. 2,400 sq ft.,
 six (6) treatment rooms, practice fully
 equipped with digital x-ray equipment, seller
 retiring, practice gross in 2014 \$535,000.

**Asking \$347,500 for Practice
 Asking \$695,000 for Building**

San Diego County #1093

Fee-for-Service restorative practice, shopping
 center location, five (5) treatment rooms,
 seller retiring, digital x-ray, laser, and intraoral
 cameras. 2014 revenues \$531,260

Asking \$385,000

Coastal Orange County #1079

Beach Location, 1,100 sq. ft., over 40 years
 goodwill, seller owned building great lease,
 2014 revenues 524,000

Asking \$385,000

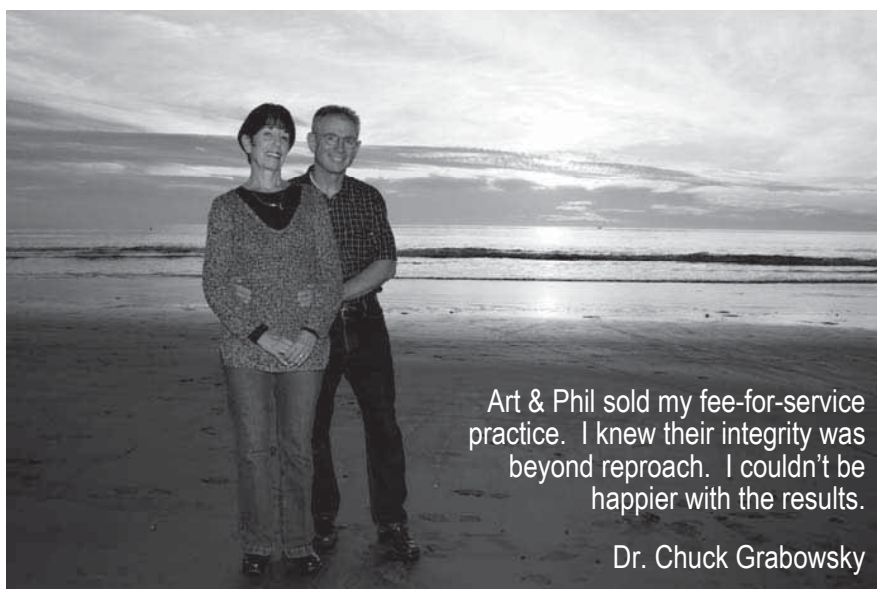

Art & Phil sold my fee-for-service
 practice. I knew their integrity was
 beyond reproach. I couldn't be
 happier with the results.

Dr. Chuck Grabowsky

Lowest price ever on Award Winning Digital Sensors. Sensors starting as low as \$3,999. Don't wait! This deal of a lifetime ends December 31, 2015. Call 1(800)397-6046.

SANTA ROSA Rare Opportunity in highly desirable area. 1050 sf w 3 ops ONLY \$150k (CN-482) WPS/800-641-4179.

BENICIA General Practice & Building. 1,545 sq. ft., 4 ops, digital X-ray & Pan, Laser. 2014 GR \$550K. HSPPT-Jim Engel 925-330-2207-#CA298.

Modern & mobile websites perfected for Dentists. TheDocSites.com \$0 Set Up For Dental Trader Readers! Risk Free! Limited Time Offer.

\$5495 New Dental Operatory, Includes Free Dentists Stool, Delivery and Install. Made in USA 10 Year Warranty. Call (800) 423 - 5657 or visit DHPDENTAL.COM for more details.

1 in 5 dentists practicing in the U.S. is licensed and practicing here in California and they advertise and read The Dental Trader. Free ads for dentists and staff. Visit <http://thedentaltrader.com/faqs.htm>. How can we help you?

NORTHERN CALIFORNIA Perio Practice, Partnership Position. 6 Ops, 1,500 Sq. Ft. Dentrax. Owner Financing Available. HSPPT-Thomas Wagner 916-812-3255-#CA168.

Intraoral Cameras ANNUAL SALE! Buy 2 for \$1664 with warranty and lifetime tech support. Use PROMO code TRADER on www.Lensiora.com.

THOUSAND OAKS Turnkey Office w charts for sale. Charts included but not guaranteed. (4) op comput G.P. (2) ops eqt'd/(2) add. plumbed. Located in a beautifully built out condo in a landmark prof. bldg. on a main thoroughfare. Newer Sirona eqt, Midmark cabinets, Dentrax s/w & digital x-rays. Seller moving, but will assist w a short transition. D&M Practice Sales 818.591.1401.

Santa Rosa GP and real estate offered for sale in well-established condominumized medical/dental complex conveniently located near Memorial Hospital. Seller is retiring. Average Gross Receipts \$256K with adj. net of approx \$110K. Asking price \$160K for the practice, and \$270K for the real estate. Contact Carroll & Company (650) 362-7004.

If delivering a better dental experience for your patients is your goal, upgrading or expanding your practice is one of the best investments you can make. Call Wells Fargo Practice Finance at 1-888-937-2321.

GET MORE!



The Dental Trader publishes far more ads placed by California dentists and their staff than any other dental publication in the country.

"Nothing says readership like participation of readers!"

Place your free ad today!

SANTA ROSA State of the art office, wonderful views, great location w/ lots of potential 900sf w/ 3ops 250k (CC-488) WPS/800-641-4179.

Every year California dentists place thousands of ads in The Dental Trader...more than any other regional or national dental publication in the nation! Join them... get results! The ads are free. Visit dentaltrader.com.

SAN DIEGO PRACTICE SALES Looking to BUY or SELL a practice in San Diego County?? Call the area experts for prompt personal service with integrity. We can also assist you with PRACTICE APPRAISALS, BUY-IN/BUY-OUT TRANSACTIONS, and LEASE NEGOTIATIONS. Call for complimentary consultation. 760-599-7828.

FOR SALE Like-new Star 430 SWL F/O Newly refurbished Have 6 only. 6-month warranty Great selling price (323) 851-6622.

NORTHERN SACRAMENTO 3 Ops, <1,000 sq. ft., PPO practice, 2 days hygiene, digital x-rays & Easy Dental. HSPPT-Thomas Wagner 916-812-3255-#CA266.

DENTAL PRACTICE AND REAL ESTATE FOR SALE IN MORENO VALLEY Freestanding Building on busy street. 2,500 sqft, 4 operatories + 1 plumbed. Call Loc Pham, Broker at LCF BRE#01875780. (714)550-7494 or practice@lcfbin.com | LCFPracticeSales.com

Envision your dream practice Now let us make it a reality. Contact Live Oak Bank for your practice financing needs. 877.890.5867 www.liveoakbank.com/healthcare.

"Jason, I want to thank you for your help and excellent advice thus far in my career. Purchasing this second practice has been a huge success this past year I appreciate all of your help!" WHITNEY GOMEZ, DDS Neverland, Texas. CALL TODAY 800-499-1474 WOOD & DELGADO www.dentalattorneys.com.

Mention this ad and get half off your closing costs.[†] Offer ends December 31, 2015.



Practice Sales and Acquisition | Start-ups | Debt Consolidation
 Deposits | Practice Relocations | Equipment and Consulting Financing
 Merchant Services | Payroll and Cash Management | Small Business Card

Flexible financing meets important insights

2013 & 2014 Townie Choice Award Winner for Best Practice and Equipment Financing

With Bank of America Practice Solutions, you get financing* and guidance that matches your needs

Over the years, we've helped thousands of dental practices become more efficient, productive and successful. We'll sit down with you, ask lots of questions and ensure that we totally understand your needs. Then, we'll develop a financial package that's customized to your practice.

Call now and we'll give you a **complimentary Dental Practice Business Plan** that can be invaluable to your business.



 Let's talk



Matthew Christie – 949.794.7440

matthew.christie@bankofamerica.com

Practice sales and acquisition



Ali Karjoo – 949.794.7447

ali.karjoo@bankofamerica.com

Start-up, commercial real-estate and construction projects

To learn more, visit bankofamerica.com/practicesolutions



Practice Solutions

Bank of America 

[§] CDA stands for California Dental Association.

[†] This offer does not include commercial real estate products.

* All programs subject to credit approval and loan amounts are subject to creditworthiness. Some restrictions may apply. The term, amount, interest rate and repayment schedule for your loan, and any product features, including interest rate locks, may vary depending on your creditworthiness and on the type, amount and collateral for your loan. Bank of America Practice Solutions may prohibit use of an account to pay off or pay down another Bank of America account.

Bank of America is a registered trademark of Bank of America Corporation. Bank of America Practice Solutions is a division of Bank of America, N.A.

©2015 Bank of America Corporation | ARMYKXPM | Rev. 05/15

REDDING Amazing Practice. Lease or Buy Real Estate! 2,860 sf w/ 4 ops. Plumbed for 2 add'l! ONLY \$285k (GG-386) WPS/800-641-4179.

"I saw your ad in The Dental Trader!" Please say this when contacting our advertisers so they know how you found them okay? We appreciate it and so will they. Thank you from the Dental Trader staff.

DENTAL PRACTICES WANTED in Union City, Newark, Castro Valley Good location. Active patient charts. Sellers call Loc Pham, Broker at LCF Financial, Inc. BRE#01875780. (714)550-7494 or practice@lcfinc.com | LCFPracticeSales.com.

Complete Dental Office Fully Equipped with Made in USA Dental Equipment for \$99 PM/OAC* Terms and Conditions apply. Call (800) 423 - 5657 or visit DHPDENTAL.COM for more details.

GP Dental Office For Sale: San Francisco Bay Area 4 OPS/Pano/1500sq. Free Standing Building Low Expenses/ Owner retire Cell: 510-619-4240.

A-DEC 511 Patient Chair & matching 611 Doctor's stool original cost \$12,000 Like New, Make Offer 855-772-7645 or janetm@hygiacare.com.

OAKLAND General Dentistry- Appx. 1,500 sq. ft., 4 Ops, Dentrix software, Dexis Digital X-ray. 2014 GR \$869K. HSPPT-Jim Engel 925-330-2207-#CA293.

Dental Buffalo No. 1A Vibrator. Never used. \$70. OBO 949-202-4420.

Intraoral Cameras on SALE! \$3149 for 4 cameras, \$2384 for 3, \$1664 for 2. Use PROMO code TRADER on www.Lensiora.com.

Hands On bone Grafting Course with live "All on Four" surgery presented by Bone bank and Dr Navid Senehi, Oral Surgeon- Woodland Hills. CE Credits + Lunch included. contact John john@fosinstitute.com / Cel 818-359-9715.

100% Demineralized Bone Matrix Putty in a syringe .07cc \$85.00 1.0cc \$125.00- these prices can't be beat www.dentalprodx.com.

SANTA ROSA General Practice/Building. 3 Ops, owner selling interest in bldg. 4 days Hyg, 10-12/day. 2013 GR \$542K w/\$182K Adj. Net. HSPPT-Dennis Hoover 209-605-9039-#CA200.

"Pat, Thank you so much for your work and advice. I'd highly recommend you to anyone!" CLINT MARTIN, DMD Wyoming, Illinois. CALL TODAY 800-499-1474 WOOD & DELGADO www.dentalattorneys.com.

FRESNO Well-established. 40-50 new Pt/mo. 1,452 sf w/ 4 fully equipped ops \$425k (JG-491) WPS/800-641-4179.

Free Retirement Plan Feasibility Study with every incorporation. Attorney Robert W. Olson, Jr., 805.963.1120, www.transdental.com.

CENTRAL MARIN COUNTY Rock solid foundation. Consistent \$700,000+ per year performer with strong Profits. 3-days of hygiene. Digital office. To learn more, go to www.PPSsellsDDS.com or send an email to Ray@PPSsellsDDS.com.

OROVILLE General Practice. 1,000 sq. ft.. Dentrix, Digital Pan & X-rays, Laser, Intra-Oral. 2014 GR \$512K. HSPPT-Dennis Hoover 209-605-9039-#CA287.

AEU-7000 E70V, Aseptic + 2 hand pieces, like new. For \$4000. Call. 562-692-7870.

ZOOM Light 3rd generation. Excellent condition, 12 hours. \$125.00. 559-435-3111.

COLTON 3 large ops. (almost 10'x10') with digital x-ray, dual sinks and cabinetry in each op. Going digital. 1200 sq. ft. Gross \$\$ up 39% this year! iepracticesales.com (951) 816-6242.

Want your Dental Trader to follow you?



Just use our Change of Address form at:

www.dentaltrader.com

and provide the address you want it mailed to.

Your home, post office box, anywhere!

The Dental Trader does not sell or share it's mailing list with anyone...your privacy is fully protected.



WESTERN PRACTICE SALES

800.641.4179

WPS@SUCCEED.NET | WESTERNPRACTICESALES.COM

Practice Transitions Made Perfect™

BAY AREA

AC-335 SAN FRANCISCO: Two great practices for the price of one! **Now Only \$475!**

AG-053 SAN FRANCISCO: 3,000 sf w/ 9 ops + 1 add'l. PRIME LOCATION! **REDUCED \$400k**

AN-490 SAN FRANCISCO: *This is an opportunity of a lifetime!* 1,000 sf w/ 4 ops. **\$795k**

BN-183 HAYWARD: *Kick it up a notch by increasing the current very relaxed work schedule!* 1,300 sf w/ 3 ops **\$150k**

BN-279 CONTRA COSTA COUNTY: Excellent Merger Opportunity! 2-story. 1,350 sf w/ 3 ops + 1 add'l **\$60k**

BC-361 OAKLAND: Established for over 23+ years! 2,200 sf w/ 7 ops. **Now Only: \$385k**

BC-381 PLEASANT HILL Facility: Open Floor Plan! 1,852 sf w/ 6 equipped ops! Move in Ready! **\$80k**

BG-407 SAN LEANDRO: Prof bldg. Great signage! 1200 sf w/ 3 ops **\$125k**

BN-426 BERKELEY: Step into this quality practice and you'll know you belong here! 1,384 sf w/ 3 ops. **\$495k**

BC-432 PITTSBURG: Own this family-oriented Practice! 1,640 sf w/ 6 ops. **\$350k**

BC-487 MARTINEZ Facility: Martinez/Pleasant Hill Border, Great for Specialist, 1750sf. 1op + 5 add'l plumbed **\$60k**

BN-463 FREMONT: Gross Revenues Exceeded \$590k in 2014 on 4 day work week! 1,720sf w/ 3op + 4 add'l. **\$485k**

BN-504 RICHMOND: Established Practice and Real Estate! 1,450 sf w/ 2 ops + 2 add'l **\$100k / RE \$700k**

CC-390 SOLANO COUNTY: Near Travis AFB! Highly visible location! 950 sf w/ 3 ops **Seller Motivated! REDUCED! \$145k**

CC-456 SOLANO COUNTY: Highly visible location! 2,997 sf w/ 6 Dr ops + 2 Hyg ops + 1 add'l **\$850k**

CC-488 SANTA ROSA: State of the art office, wonderful views, great location w/ lots of potential 900sf w/ 3ops **250k**

CN-482 SANTA ROSA: Rare Opportunity in highly desirable area. 1050 sf w 3 ops **ONLY \$150k**

DC-370 SAN JOSE: Facility Only. 1,600 sf w/ 3ops. Real Estate also available for purchase **\$120k (Real Estate \$1.5M)**

DC-476 DUBLIN: Shared Facility. Great for Specialist - Endo, Pedo or Ortho. 1100 sf w/ 2 ops + 1 add'l **\$125k**

DC-419 NEWARK Facility: Location, Location, Location! High Traffic Area, 1,400 sf w/ 4 ops **\$120k**

DC-406 SAN JOSE: Amazing opportunity in Westgate Shopping Center. 6 ops + 80 mall hours per week **\$400k**

BAY AREA CONTINUED

DG-499 SARATOGA Facility: 2 fully equipped ops & room for 1 add'l w 1,178sf. Move-In Ready **\$150k**

DN-467 GILROY Facility: This traditionally styled practice is perfectly situated! 1,325 sf w/ 3 ops + 1 add'l. **\$75k**

DN-497 PLEASANTON Facility: Great Location! 870 sf w/ 3 ops + 1 add'l. **Owner Financing w/10% Down! Reduced! \$95k**

NORTHERN CALIFORNIA

EN-340 SACRAMENTO: Large HMO practice! 3,400 sf w/ 10 ops and Plumbed for 1 add'l **\$950k**

EN-378 LINCOLN: quality practice with a wonderful patient base! 1,369 sf w/ 2 op + 3 add'l. **\$170k**

EN-379 ROSEVILLE: An amazing opportunity in the location of your dreams! 1,040 sf w/ 3ops. **\$295k**

EN-423 FOLSOM Oral Surgery Facility: 3,450 sf w/ 2 Lrg. Treatment Rooms. **Now Only \$1 w/ Lease Assumption!**

EN-464 ROCKLIN Facility: Don't miss out on this remarkable opportunity! 2,150 sf w/ 4 ops. **\$150k**

EN-477 DAVIS: Rare Opportunity! 4 ops each w digital xrays. No corners cut here! **\$320k**

EN-475 ROSEVILLE Facility: Hesitate and you might miss out on this opportunity! 875 sf w/ 2 ops + 2 add'l. **\$49.5k**

EG-479 FOLSOM: History is alive here with tributes to the past! 1,600 sf w/ 3ops. **\$225k**

EG-496 AUBURN: Associate-Driven HMO practice in Downtown. 3 fully equipped ops **\$315k**

EN-484 FOLSOM Facility: Come live, practice and grow here! 1,934 sf w/ 4 Ops. **\$150k**

EN-503 FOLSOM Facility: Take a close look at this opportunity! 2,150 sf w/ 5 ops. **\$225k**

EG-508 FOLSOM Facility: You'll want to spend your days here! 1,500 sf w/ 4 ops + 1 add'l. **\$60k**

FN-299 FERNDALE: Live and practice on the beautiful North Coast! 1,300 sf w/ 3 ops **\$195k (Real Estate: \$309k)**

FC-334 NORTHERN CA: Emphasis on prevention. 1,200 sf w/ 4 ops **\$480k / Real Estate Also Available!**

FC-343 NORTHERN CA: Quality & location are the keys to success! 1,200 sf w/ 3 ops + 1 add'l & 1 hyg. Op. **\$500k (Real Estate \$375k)**

FC-415 FT. BRAGG: Excellent practice in peaceful, family-oriented community! 1,800 sf w/ 5 ops + 1 hyg. Op. **\$425k**



Timothy Giroux, DDS



Jon B. Noble, MBA



Mona Chang, DDS



John M. Cahill, MBA



Edmond P. Cahill, JD

NORTHERN CALIFORNIA CONTINUED

GC-472 ORLAND: Live & Practice in charming small town community. 1,000 sf w/ 2ops. Seller Retiring. **\$160k**

GG-386 REDDING: Amazing Practice. Lease or Buy Real Estate! 2,860 sf w/ 4 ops. Plumbed for 2 add'l! **ONLY \$285k**

GG-453 CHICO: 5,000 sf 7 ops Perfect for 1 or more dentists! **\$395k**

GG-454 PARADISE: ~2,550 sf w 9 ops. 40 yrs goodwill! Amazing Opportunity! **\$595k**

GN-201 CHICO: Beautiful practice, major thoroughfare, stellar reputation! 1,400 sf w/ 4 ops & room for another **\$425k**

GN-244 OROVILLE: Must See! Gorgeous, Spacious. 2,500 sf w/5 ops! Collections over \$450k in 2013. **Only \$315k**

GN-258 REDDING: Pristine and attractive! Conveniently located! 2,100 sf w/ 3 ops + 2 add'l. **Now Only \$300k!**

GN-399 REDDING: Loyal patient base and relaxed workweek schedule. 1,440 sf w/3 ops. **\$150k**

GN-418 REDDING: **Goodwill Galore!** Established for ~37 years. Seller is retiring! 3,200 sf w/6 ops +2 add'l. **\$495k**

GN-507 CHICO: It just doesn't get any better than this! 3,000 sf w/ 7ops. **Practice \$535k Real Estate \$750k**

HG-298 REDDING FOOTHILLS: **HEALTH FORCES SALE!** Includes Cerec! 2,000 sf w/ 5 ops. **Practice \$75k & Real Estate Also Available!**

HN-213 ALTURAS: Close to Oregon Border. FFS practice is 2,200 sf w/ 3ops +1 add'l **\$115k**

HN-280 NORTHEASTERN CA: "Only Practice in Town" 900 sf w/ 2 ops **\$110k**

HN-290 PLACERVILLE: **Excellent Merger Op!** FFS. 1,400 sf w/ 4 ops **\$210k**

HG-448 LAKE TAHOE AREA: **Call for Details!** Upscale Family Practice. 3400sf w 6 ops **\$725k**

CENTRAL VALLEY

IG-367 MERCED: Newly Remodeled, Paperless. 1,550 sf w/4 ops **REDUCED! \$305k**

IG-470 TRACY: Amazing opportunity. 1300 sf w/ 4 ops **\$270k**

IN-345 MODESTO: Long-standing tradition of quality care. 3016 sf w/ 5ops + 1 add'l. **\$495k**

IN-358 MODESTO: Practice nets over 50%! 1,200 sf, 3 ops+1 add'l. **REDUCED! \$275k**

CENTRAL VALLEY CONTINUED

IN-397 FRESNO/MADERA: Focused on quality dental care & patient comfort! 2,000 sf w/5ops. **Seller Motivated: \$440k**

IN-429 TRACY Facility: "Move-in ready" Hesitate and you might miss out! 2,488 sf, 5 ops **\$245k/RE: \$650k**

IN-474 STOCKTON: Too good to be true? Absolutely not! 1,600 sf w/ 3 ops. **\$95k**

IC-468 SAN JOAQUIN VALLEY: High-End Restorative Practice! Don't miss out! 2,500 sf w/ 6ops. **\$425k**

IN-506 TURLOCK: Practice in the heart of the Central Valley! 2,000 sf w/ 5ops + 1 add'l. **\$425k**

JC-349 FRESNO Facility: Motivated Seller retiring! Step right in and make yours! **Call for Details!**

JG-491 FRESNO: Well-established. 40-50 new Pt/mo. 1,452 sf w/ 4 fully equipped ops **\$425k**

SPECIALTY PRACTICES

I-9461 CENTRAL VALLEY Ortho: 1,650 sf w/5 chairs/bays & plumbed for 2 add'l **\$180k**

CC-346 SO MARIN CO Perio: 1,142 sf w/ 3 ops. Meticulously maintained! **REDUCED! \$199k**

BN-393 PINOLE Pedo: Popular Pedo Practice w 2,000 sf & 5 ops. **\$1.2m**

CG-424 NAPA Prostho: Ready for Experienced, high-end Prosthodontist! One track to collect just under \$1m **\$725k**

CC-405 SOLANO CO. Endo: Endodontic Practice in a vibrant community! 1,250 sf w/ 4 ops. **\$485k**

IC-267 CENTRAL VALLEY Ortho: beautifully landscaped. 1,728 sf w/ 6 chairs/bays + 1 add'l. **\$225k / Real Estate Also Available!**

DC-459 SF PENINSULA (Perio): 50% Partnership Buy In! Call for Details! **\$580k**

CG-481 S SONOMA CO (Ortho): 2070 sf w 7 chairs + 1 exam in Med/Prof Plaza **\$295k**

We are a proud member of:



DENTAL TRANSITIONS™

VALUATIONS | SALES | CONSULTING

— DID YOU ACQUIRE A DELTA PREMIER DENTAL PRACTICE BETWEEN 2011 AND MAY 1, 2014?

— WERE YOU REQUIRED TO ALSO TAKE DELTA'S PPO PROGRAM IN ORDER TO MAINTAIN DELTA PREMIER?

— WOULD YOU LIKE TO TERMINATE YOUR PPO RELATIONSHIP AND MAINTAIN DELTA PREMIER?



**PATRICK J. WOOD
& JASON P. WOOD**

ATTORNEYS AT LAW

**If so, we may have
a solution for you.
Please call our firm for a
free consultation and see if you
qualify to DROP THE PPO!**

800-499-1474
www.DentalAttorneys.com

THE AUTHORITY IN DENTAL LAW

Specializing In

Practice Acquisitions/Sales • Partnerships
Business Transactions • Lease Negotiations
Estate Planning • Transitions
Business Litigation

RDAs needed for new Ridgecrest Pediatric office. Currently P/T. Send resume to gilbedan@gmail.com.

GP dentist for hire 3-4 days or per diem, comprehensive treatment to include molar RCT and Implants. SFDentist2016@gmail.com 559.471.5551.

gently used dentist and assistant chairs (3 sets) for sale-\$175/set. Please contact coronadental4@gmail.com for more information.

Biolase C100 hard/soft tissue laser for sale. Glasses and tips included. Sshamoiei@gmail.com

RICHMOND Established Practice and Real Estate! 1,450 sf w/ 2 ops + 2 add'l \$100k /Real Estate \$700k (BN-504) WPS/800-641-4179.

GENDEX PANOREX ORTHORALIX 9000. was purchased 2000. film type great, condition, \$4950. Call 909-899-8757.

SAN FRANCISCO BAY AREA PERIO PRACTICE Phenomenal "business model". 2015 trending \$1.3 Million on part-time schedule by choice. Profits shall top \$700,000. This is a "once-in-a-career" opportunity. For further information, contact Ray Irving at 415-899-8580, Ray@PPSsellsDDS.com or www.PPSsellsDDS.com.

Massage Dental Chair Made in USA, 150 Color Choices, 10 Year Warranty \$3495. Call (800) 423 - 5657 or visit DHPDENTAL.COM for more details.

We thrive because of you! Referrals from dentists and their staff directing new advertisers to The Dental Trader is our #1 source of new business. Thank you very much for making the introduction for us! We at The Dental Trader greatly appreciate it!

ESPE Pentamix 2 in very good condition for \$125 Call 989-390-1998.

DENTAL PRACTICES WANTED in OC and LA County Gross 400K+. Strip mall, anchored business. Sellers call Loc Pham, Broker at LCF Financial, Inc. BRE#01875780. (714)550-7494 or practice@lcfinc.com | LCFPracticeSales.com.

MARTINEZ Facility Martinez/Pleasant Hill Border, Great for Specialist, 1750sf. 1op +5 add'l plumbed \$60k (BC-487) WPS/800-641-4179.

OXNARD (4) op comput. G.P. for sale. Located in a prof. bldg. with ample free parking. Dentrix s/w & digital x-rays. 2014 Gross Collect \$264K+ on a (3) day week. Cash/Ins/PPO/HMO/Denti-Cal pts. Seller refers diff. Endo & O.S., all Perio & Ortho. & does no advertising. Seller taking non profit position. D&M Practice Sales 818.591.1401.



FACTOID: 30% of all used dental equipment placed for sale on The Dental Trader Ad Board sells before the ads ever appear in print. New items appear daily.

dentaltrader.com

Attend an Endo Lecture and an 8 CE Intro to Dental Sleep Medicine for only \$299, Both on Sundays (15 CEs), in a convenient San Jose location! Visit www.xcelseminars.com for info.

SAN FRANCISCO Periodontal Practice & Condo. 1,160 sq. ft. w/4 Op, 2014 GR \$714K w/\$363K Adj. Net. HSPPT-Dennis Hoover 209-605-9039-#CA274.

Bone Graft and Membrane prices at the lowest you have ever seen advertised. Bone Bank is one of the very few actual FDA approved mfg's of regenerative products in the US. \$35.00 Per CC vial of Mineralized or demineralized human bone. Contact Elke@SynergySpecialists.com 323-828-9362.

ROSEVILLE New listing. Call today for more information! IntegrityPracticeSales.com, Broker Bill Kimball, DDS, BRE #01911548. (855) 337-4337.

PRACTICE FOR SALE GP in NATIONAL CITY. 3 Ops, 4 year old equipment in approx. 1163 sq. ft. DPS: 760-599-7828.

We are THE LEADING ADVISORS to more than 15 DENTAL SOCIETIES. See our website for upcoming events/seminars in your area. 800-499-1474 WOOD & DELGADO www.dentalattorneys.com.

OROVILLE General Practice. 3 Ops, mostly new equipment & recently remodeled. Owner retiring. HSPPT-Dennis Hoover 209-605-9039-#CA288.

CLARIS i4D IntraOral Camera. The ultimate everyday IntraOral camera. Sony CCD sensor. Clearer Image. Expertly engineered. 2 year warranty. Brand new. List: \$3,995. Sale: \$2,750. Call 310-204-6134 and ask for Mark.

FOLSOM Facility Come live, practice and grow here! 1,934 sf w/ 4 Ops. \$150k (EN-484) WPS/800-641-4179.

INLAND EMPIRE PRACTICE SALES

SERVING THE INLAND EMPIRE AND COACHELLA VALLEY EXCLUSIVELY!!
LOCAL, PERSONALIZED SERVICE, FOCUSED ON YOUR TRANSACTION!



COLTON - Fantastic 3 Operator, 1200 sq. ft. office!! Established 10 years, with large operatories (approx. 10' x 10'), digital x-ray each room. Gross \$\$ up 39% this year! Efficient, yet spacious layout. Sink and cabinetry each side of Op. Transitioning to paperless. Excellent condition. Great location on major thoroughfare near freeway. Solid patient base, well priced with great growth potential!

SAN BERNARDINO - Doctor retiring from her attractive General Practice with 20 years of goodwill!. It is located near the University, on a major road in a largely residential area. The office has 4 operatories (3 equipped) in 1330 sq. ft. Seller refers out Lots of dentistry. No HMO, capitation plans, or Denti-Cal. Great price!



COLTON - Doctor selling his satellite office to consolidate to his main office. Leasehold improvements and equipment, no patients included with purchase. Excellent location located near freeway exit. Good street side exposure. The office has 4 operatories with 3 equipped, with panoramic x-ray in 1900 sq. ft. Equipment in great condition. Very affordable price!

WHY CHOOSE US?

* Local * Personalized Service *

***I personally** meet with you at all stages of transaction. (Listing, Marketing, Negotiation, Consultants, Escrow)*

***I personally** show your office.*

***I personally** assist the Buyer to facilitate an efficient and smooth transaction.*

WE HAVE BUYERS FOR YOUR PRACTICE !!

IN: RANCH CUCAMONGA, ONTARIO, CORONA, EASTVALE, RIVERSIDE, N. SAN BERNARDINO

SEE OUR WEB SITE!!



Thomas Fleming

Lic.#01168222

RECENT SALES

Fontana - 5 op., 2300 sq. ft.

Fallbrook - 3 ops., 900 sq. ft.

Inland Empire Practice Sales

c. 951.852.2560 • f. 951.244.6182 • iepracticesales.com

Inland Empire Practice Sales: a subsidiary of San Diego Practice Sales

Buy it! Sell it! Trade it!!!

FREE ONLINE CLOUD BACKUP up to 2GB. HIPAA Compliant with full data encryption. See www.ez2000dental.com, then click Products Link, then click Cloud Backup Services, and Download the FREE LINK. Need help? Call 800-273-5033. No charge for our assistance.

Want to build a thriving practice? Call Wells Fargo Practice Finance for a complimentary consultation today, at 1-888-937-2321.

Whether you need help funding a ground up construction project, purchasing commercial property, refinancing or consolidating existing loans or acquiring a practice, Live Oak Bank can help. 877.890.5867 www.liveoakbank.com/healthcare.

Intraoral Cameras INVENTORY LIQUIDATION! \$3149 for 4 cameras, \$2384 for 3, \$1664 for 2. Use PROMO code TRADER on www.Lensiora.com.

Lowest prices on Regenerative Products- Buy 3 get 1 on all Miltex Collagen Products! 15 x 20mm Helimends @66.00 www.dentalprodx.com.

ROSEVILLE Great foundation. 2015 trending \$350,000. 3-ops with 4th available. Convenient location on Douglas Boulevard. End cap suite in strip center with fantastic exposure. To learn more, go to www.PPSsellsDDS.com or send an email to Ray@PPSsellsDDS.com.

PLEASANTON Facility: Great Location! 870 sf w/ 3 ops + 1 add'l. Owner Financing w/ 10% Down! Reduced! \$95k (DN-497) WPS/800-641-4179.

ONC Certified Electronic Health Records (EHR) In Your Practice Management Software. Achieve a higher level of care for your patients with EHR. If you have 30% or more Medicaid visits you could also receive up to \$63,750 in government incentive payments. Call 1(800)397-6046.

"Radius" Dental Operatory Right and Left Use. American Manufactured, 10 Year Warranty \$5995 Delivered and Installed. Call (800) 423 - 5657 or visit DHPDENTAL.COM for more details.

Legal Tip Does it matter whether the sale closes this or next year? Attorney Robert W. Olson, Jr., 805.963.1120, www.transdental.com.

COASTAL OC General Practice for Sale, Asking \$385K, for more details contact Brooke at 714-259-0501.

Luis Kong, DDS (San Francisco, CA)- Thank you Dr. Chester Jeng of Law Offices of Jeng and Associates. Your prompt attention to my concerns is something I am so thankful for. Definitely, you are the "go to" attorney for me. Call Jeng & Associates 714-858-0536.

REDDING FOOTHILLS HEALTH FORCES SALE! Includes Cerec! 2,000 sf w/ 5 ops. Practice \$75k & Real Estate Also Available! (HG-298) WPS/800-641-4179.

SACRAMENTO 2,500 sq. ft., 6 equip. Ops, 1 add'l plumbed. Digital X-ray, Intra-oral, Pano. 2014 GR \$788K. HSPPT-Thomas Wagner 916-812-3255-#CA297.

Dental Hygiene Instruments and Cassettes for Sale. Email darabantp@yahoo.com for photos. \$1,200.

Is it time to consolidate your loans? Let's talk about how we can work together to simplify your finances. Call Wells Fargo Practice Finance at 1-888-937-2321.

Look for your free wall-hanging color calendar in this edition...compliments of The Dental Trader Advertisers!

Practice for sale San Rafael (Marin County). 3 ops: 1 hygiene, 2 Operative. Can ad another. abm4678@gmail.com. Contact for info.

Econo-Vac suck down heater (vacuformer) for sale, Only used lightly & working great \$299 OBO 3109805265.

Ronadro "Dentistry Past" statue for sale \$3995! Near-perfect condition; custom name plate available. Call Dr. Jerry Young to inquire: 714-680-3063.

Don't See Your Ad?



Every week dozens of people place reader ads but forget to include a phone number or email address, others exceed the 20 word limit for free ads so we must delete them. This happens over 100 times a month! If you don't see your ad, this may be why. Be sure to include some form of contact info so our readers can respond and don't try to squeeze in extra words.

Free Consultation

PROACTIVE **SEO** *SOLUTIONS*

LET US BUILD YOUR ONLINE FOUNDATION

Our Services Include

- Responsive Website Design
- SEO (Search Engine Optimization)
- PPC (Pay Per Click)
- Social Media Management
- Reputation Management
- Video Production
- Phone Tracking
- +more

Call (310) 994-1136

EXPERIENCED PATIENT, PRESENTABLE In-House Endodontic Specialist searching for offices wanting to double production USING PROVEN METHODS TO RETAIN PATIENTS. 1EndoInYourOffice1@gmail.com.

FOLSOM Facility You'll want to spend your days here! 1,500 sf w/ 4 ops + 1 add'l. \$60k (EG-508) WPS/800-641-4179.

PINOLE Endodontic Practice.- 4 Ops w/Digital X-ray, Microscopes, PBS Endo software. 2014 GR \$672K. HSPPT-Jim Engel 925-330-2207-#CA284.

DENTAL PRACTICES WANTED in Pasadena, Studio City, Monrovia Fully digital. Existing patient base. Sellers call Loc Pham, Broker at LCF Financial, Inc. BRE#01875780. (714)550-7494 or practice@lcfinc.com | LCFPracticeSales.com.

FOR SALE Midwest Quiet-Air Insight F/O Handpieces(2). Just overhauled. 6-month Warranty. Push-button head or Bur Key.(323)851-6622.

COLTON Just listed! Equipment and leasehold improvements. 3 ops equipped. with 4th possible, Panoramic. Good location and visibility. iepracticesales.com (951) 816-6242.

Ortho Sub! Need to take a break? Keep your office open! Call Kathleen - 626.590.9327.

FRESNO Priced to sell. Great retail location with easy parking and 6 ops. Ready for a busy dentist. IntegrityPracticeSales.com, Broker Bill Kimball, DDS, BRE #01911548. (855) 337-4337.

MOUNT SHASTA Small town living renowned for outdoor recreation and abundant culture. Perfect escape from Rat Race and corporate intrusion. On 3-day week, 2015 trending \$850,000 with \$450,000 in Profits. To learn more, go to www.PPSsellsDDS.com or send an email to Ray@PPSsellsDDS.com.

Need to buy digital sensor,practice software managment,digital scanner.digital panorex machin. Please,call 9497352064.

experienced productive, excellent bedside mannered General Dentist of Palo Alto/Bay Area looking for a P/T job. Contact: sunlight218@gmail.com.

CEREC 3 Redcam with Milling Unit With lots of supplies. \$9,000 OBO syk9020@gmail.com.

FREE PHONE CONSULTATION AND GUIDANCE FROM THE LEADING DENTAL ATTORNEYS IN THE COUNTRY? What do you have to lose? CALL TODAY 800-499-1474 WOOD & DELGADO www.dentalattorneys.com.

GE B40 Patient Monitor Arrythmia, CO2/O2, BP Detection/Roll Stand- Never used. \$2,500 OBO. Contact (865)657-8086, gmbdds@gmail.com.

TURLOCK Practice in the heart of the Central Valley! 2,000 sf w/ 5ops + 1 add'l. \$425k (IN-506) WPS/800-641-4179.

2 new endo reciprocating handpieces by W&H for standard hand files includes factory e-type motor \$1100ea 818 522-1745 hksr9tc@gmail.com.

Treatment Coordinator needed in Sunnyvale for high volume children's dentistry. Full time + benefits. Send Resume to: dtresume@cdgdental.com.

Wanted Dr. looking to rent space to see patients/build a practice. GP office in Hayward available immediately. Contact heritagedentalx2@gmail.com.

Small papoose board and PediWrap for sale. Olympic Medical. LA county. Email: sugarbug888@gmail.com. \$200.

seeking experienced RDH with great customer service, energetic and bilingual/spanish. part time position available. email your resume to: mrs.sandoval86@gmail.com.

FOR SALE Zila pro-select platinum dental ultrasonic piezo scaler system. Used,in great working condition. \$1950, obo Contact: dds714@yahoo.com 415-895-0477.

looking for PERIODONTIST to join a fast growing surgical group in all California .please send your resume info@drmalboubi.com 9492000600 5105160027.

SAN FRANCISCO This is an opportunity of a lifetime! 1,000 sf w/ 4 ops. \$795k (AN-490) WPS/800-641-4179.

I am interested to buy (ScanX USB inline eraser for panoramic and cephalometric plates) in good working condition 818 383 5797.

Looking to finance a practice? Contact Live Oak Bank. Our specialized lenders will build a customized loan to meet your financing needs. 877.890.5867 www.liveoakbank.com/healthcare.

General dentist needed for South Texas practice, 250K+ earning potential, new grad/H1-B ok. contact: jmeski@gmail.com.

FOR Sale Mid-West Shorty 2-speed Slow Handpiece Will sell with or without various attachments Like new-Great Price(323)851-6622.



We bring specialists to you.



Stop referring your production away

- O.S., Endo, Perio, Ortho, and Pedo
- Innovative complimentary guidance and training make transitioning a breeze
- Insurance credentialing and guidance
- Specialists will bring their own equipment including surgical kits, implants motors, endo units, and instruments



Contact us today 855-796-7374

www.synergyspecialists.com | info@synergyspecialists.com

NEW LED Chair Mounted Dental Light - \$1595, Year End Discount \$600, now only \$995. Call (800) 423 - 5657 or visit DHPDENTAL.COM for more details.

Dentist Buy-in opportunity with established business for San Jose, Santa Clara, Monterey, Salinas, Santa Cruz locations. Send CV to bayareadentist2009@gmail.com.

SACRAMENTO 1,684 sq. ft., 6 equip. stations in bay, 2 add'l plumbed. 2014 GR \$590K. HSPPT-Thomas Wagner 916-812-3255-#CA269.

Legal Tip: Buyers It takes 15 years to fully deduct allocations to goodwill. Attorney Robert W. Olson, Jr., 805.963.1120, www.transdental.com.

AUBURN Associate-Driven HMO practice in Downtown. 3 fully equipped ops \$315k (EG-496) WPS/800-641-4179.

New dentist looking to start or buy a practice? Call Wells Fargo Practice Finance at 1-888-937-2321.

Is your ad missing? Check the automated confirmation you received via email when submitting your ad, see if you exceeded 20 words w/o paying, forgot to include your phone number or email address. Did you miss the deadline? It's always the 7th of the preceding month.

SAVE YOURSELF SOME TIME



Read The Dental Trader online.

All those email and website addresses are hyperlinked when you view the publication in pdf format. Click on **EDIT**, then on **SEARCH** to quickly locate something specific. Online readers get a ten day jump on those who wait for it to arrive in the mail and score the best bargains.

CHANGE OF ADDRESS FORM



OLD ADDRESS

Dentist's Name _____

Address _____

City/State/Zip _____

NEW ADDRESS

Dentist's Name _____

Calif. Dental License # _____

Address _____

City/State/Zip _____

Phone _____ Fax _____

E-mail _____

Authorizing signature _____

PLEASE MAIL TO:
PO Box 2631, Capistrano Beach, CA 92624
 or Fax this form to 949.498.1198
 on or before the 1st of the month.
 For faster filing, submit this form online at:
www.dentaltrader.com

FOLSOM Facility Take a close look at this opportunity! 2,150 sf w/5 ops. \$225k (EN-503) WPS/800-641-4179.

DENTIST Consulting firm seeking Practice Transition Consultant. Full Training and support. Unlimited earning potential. careers@paragon.us.com. 866-898-1867.

HU-FRIEDY INSTRUMENTS: Gracey (11/12)(13/14), Scaler (H5/U15), Explorer, Columbia, Barnhart, Morse. Like New, Make Offer 855-772-7645 janetm@hygiacare.com.

TOUCH N HEAT SYBRON ENDO BUCHANAN HEAT PLUGGER TIPS DIFF SIZES ALL NEW U.S. MADE. \$89. PayPal eismaildds@yahoo.com.

Sacramento Dentist needed new grads welcome! Bilingual English/ Vietnamese Full time/Part time Fax (916) 399-9413 Email pacificdental65@gmail.com.

Copyright 2015 THE DENTAL TRADER. All rights reserved. No part of this publication may be reproduced or transmitted in any form or by any means, electronic or mechanical, including photocopy, recording, or any storage of information and retrieval system.

DENTAL DIRECTORY

LEE SKARIN AND ASSOCIATES, INC.

KURT SKARIN

DENTAL PRACTICE SALES & APPRAISALS

530 W. Stafford Road, Westlake Village, CA 91361
805.777.7707 • 800.752.7461 • Fax: 805.777.0051
Email: lsainc@aol.com
www.leeskarinandassociates.com



CA DRE: 00863149



Your voice for excellence through education and advocacy

The only organization dedicated to the needs of the general dentist. Learn more about everything that AGD has to offer by visiting www.agd.org and

Join Today!

Call toll-free at 888.AGD.DENT (888.243.3368)

Practice Financing



Call us for a complimentary consultation today.

Andrew Ventura
East Bay, Northern CA, HI
1-855-853-4751

Brandon Finazzo
San Francisco Bay Area
1-888-874-1590

Or visit us at wellsfargo.com/dentaltrader.



Go for the best - Get the *Highest Rated Software* by the ADA*

800-273-5033

Online demo - www.ez2000software.com



Western Practice Sales

Dentists Serving Dentists

800.641.4179

wps@succeed.net
westernpracticesales.com



Timothy G. Giroux, DDS



KINGS TWO DENTAL SUPPLY

Your One Stop Dental Shop

- Large Equipment
- Small Equipment
- Service Department
- Dental Supplies
- Ortho Products
- Digital Imaging
- Implantology
- Handpiece Repair
- Full Service Dental Lab

Tel: 800.715.5464

Fax: 626.581.8137

TAX • FINANCIAL ADVISORY • VALUATION

CUONG LE, CPA



2020 Pico Blvd., Suite C
Santa Monica, CA 90405

(310) 450-5708
le@lecpa1.com

Success Through Diligence

Rope in Profits!



www.DentalTrader.com

CALIFORNIA PRACTICE SALES INC.



John W. Knipf
President

Robert A. Palumbo
Executive Vice President

326 W. Katella Ave. #4-G, Orange, Ca 92867
(714) 639-2775 • www.calpracticesales.com

CA DRE #00491323

DENTAL DIRECTORY

ROBERT W. OLSON, JR.

a Professional Corporation
Business, Corporate & Real Estate Law

- USC Law 1984, Dartmouth 1981
- All Inclusive Packages
- Free Website Services

888.963.1120
www.transdental.com
RWO@transdental.com



Reign in more cash!

*Check out
our website!*

www.dentaltrader.com



LCF
FINANCIAL
SERVICES

Healthcare Financing & Consulting

***Low rates**
for qualified borrowers

(714) 550-7494 • www.lcffin.com

A Division of LCF Financial, Inc. *OAC

HENRY SCHEIN®
PROFESSIONAL PRACTICE TRANSITIONS

No. CA: 1.800.519.3458 • So. CA: 1.888.685.8100

ppt@henryschein.com
www.henryscheinppt.com



**CHECK OUT
OUR READER AD
FORM ONLINE**

www.DentalTrader.com

THE #1 DENTAL LAW FIRM IN THE NATION



WOOD AND DELGADO



Patrick J. Wood,
Jason P. Wood
& Marc Ettinger
Attorneys at Law

- Legal Advisors to over 15 Dental Societies
- The Chosen experts on Business Transactions for Dentaltown
- 180+ Dental Practice Transitions in 2014
- Providing service to clients NATIONWIDE

800-499-1474
www.DentalAttorneys.com



PRACTICE SALES AND LEASING
"THE PERSONALIZED SERVICE DENTAL BROKER"®



Paul Maimone
Broker/Owner

P.O. Box #6681, Woodland Hills, CA 91365
Phone: 818.591.1401 • 866.425.1877 Outside So. CA
www.dmppractice.com CA Broker Lic. #01172430



The smart way to
shop or trade

Advertise with us!

www.DentalTrader.com



Professional Practice Sales

Buying or Selling a Dental Practice?

Know Your Options

Talk to the Professionals

Contact: Ray Irving
San Francisco: (415) 899-8580
Sacramento: (530) 894-0700
www.PPSellsDDS.com



San Diego Practice Sales

- represents Sellers and Buyers
- exclusively in San Diego County
- more than 28 years of experience with the San Diego Dental Community

For More Information Call:

(760) 599-7828

WWW.SDPRACTICESALES.COM

Reach every dentist in California!

Submit your reader ad online!

See FAQs page at dentaltrader.com for instructions

Your ads post instantly to Ad Board!

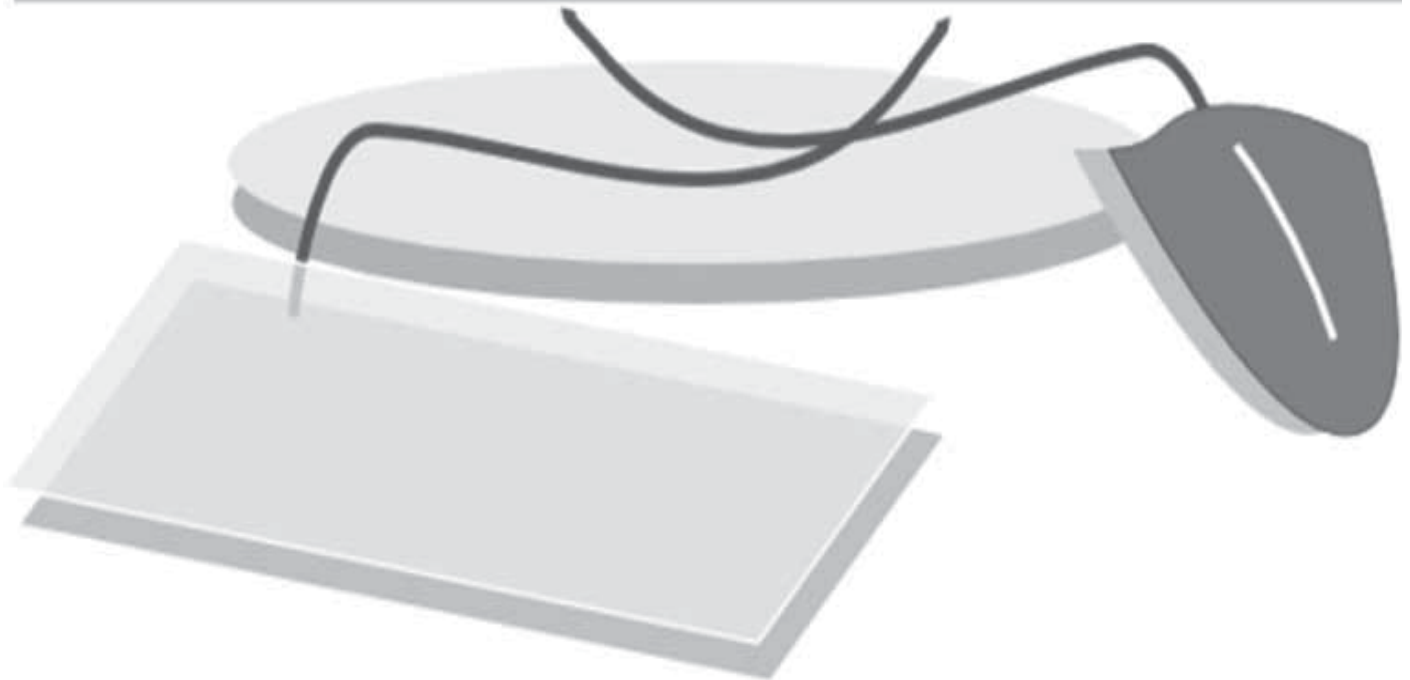

dentaltrader.com



Professional Practice Sales of The Great West

Specialists in the Sale and Appraisal of Dental Practices

If you want your practice "For Sale", we are not the firm for you.

If you want your practice "SOLD", contact us!

For complete details on any of these opportunities, go to www.PPSsellsDDS.com

- 6095 PINOLE'S APPIAN WAY** 2014 and 2015 are mirror images. Production was and shall be \$475,000 and collections were and shall be \$435,000. 3-days of hygiene. Delivery systems were upgraded 8-years ago. Strong foundation here.
- 6094 SAN FRANCISCO BAY AREA – PERIO PRACTICE** Phen-nomenal "business model". 2015 trending \$1.3 Million on part-time schedule by choice. Profits shall top \$700,000. Superlatives too numerous to mention. This is a "once-in-a-career" opportunity.
- 6093 CENTRAL MARIN COUNTY** High quality practice available in "hub" of Marin County. Rock solid foundation. Consistent \$700,000+ per year performer with strong Profits. 3-days of hygiene. Digital office.
- 6092 ROSEVILLE** Great foundation. 2015 trending \$350,000. 3-ops with 4th available. Convenient location on Douglas Boulevard. End cap suite in strip center with fantastic exposure.
- 6091 MODESTO** 3-day per week practice collected \$450,000 in 2014. Collections through July 23rd for 2015 were \$256,000. 3-days of Hygiene. Great rent of \$2,085 for 1,763 sq.ft. 5-op suite. Centrally located off Briggsmore Avenue. Hands-on Successor shall do very well here.
- 6089 MOUNT SHASTA** Small town living renowned for mountain recreation, lakes & streams, fishing, golfing and abundant culture. Perfect escape from the Rat Race and corporate intrusion. On 3-day week revenues topped \$800,000 in 2014. 2015 trending \$850,000 with \$450,000 in Profits.
- 6088 SANTA CRUZ** Well established lots of patients. Strong Hygiene Department with 3.5 days of hygiene per week. Collected \$600,000 in 2014. 2015 trending \$675,000+.
- 6087 LAKE TAHOE - NEVADA'S STATELINE** Located adjacent to California's South Lake Tahoe. Fee- for-Service" as practice is "Out-of-Network" with insurance companies. Collections last year topped \$600,000 with Available Profits of \$220,000. 3.5 days of hygiene per week. Escape California income taxes! Nevada State Board of Dental Examiners accepts the Western Boards.
- 6081 SANTA CLARA** El Camino Real location. 2014 collected \$687,000. 2015 is tracking \$775,000 with Profits of \$325,000. Management is on cruise control. New Doc who is ambitious and extends hours shall push practice over \$1 Million very quickly. 5-ops in 1,700 sq. ft.
- 6080 SAN RAMON** 8+ days of Hygiene per week. \$450,000 invested in 6-Op office. Collects \$900,000+ per year performer. Attractive transition arrangements available.
- 6071 CHICO** Strength is 4-day Hygiene schedule. Retiring DDS focuses on restorative. Endo, OS, Perio & Pedo referred. 2014 collected \$450,000. Beautiful 4-Op office. Full Price \$150,000.
- 6070 VISALIA** Strong foundation and well-positioned for ambitious successor. Strong Hygiene Department, beautiful facility, well equipped. Digital throughout. Not a Delta Premiere practice. Revenues trending \$700,000 for 2015 on part-time schedule. Extend hours and be busier. Best location!

Professional Practice Sales of The Great West



Ray and Edna Irving
(415) 899-8580 ~ (800) 422-2818
www.PPSsellsDDS.com

For complete details on any of these opportunities, go to www.PPSsellsDDS.com

Thinking on selling your practice? Call "PPS of The Great West" today.
This shall be the best decision you make regarding this important change in your life!

"I listed with a competitor for 12 months. Had two people visit my practice. First weekend PPS had my listing. I had 3 people visit and an offer by the end of the first week. Thank you for allowing me to move on to the next step of my life."

"It was a pleasure to work with PPS. I had to sell because of health complications. Mr. Irving listed my practice on Jan 1st, we closed escrow on Feb 27th. It took him less than 60 days to complete the sale as promised."

"When I decided to sell my ortho practice, I sought the services of a large company. Over the 12-month contract, I had one buyer visit. Word was out. It had a devastating effect on my bottom line. Fortunately, I found Ray and Edna Irving! When I finally sold, I choose between two good offers. My regret was the time and money lost with the other guys."

"When I signed the Listing on June 1st, Ray stated he would have the practice sold by Labor Day. The sale was concluded on Sept 1st, two days before Labor Day. Wow!"

"I will always remember your statement when I questioned your contract being only four months. You stated: 'If I can't sell your practice in that time, you should get someone else.' Well, you did with time to spare!"

"Before I called Ray, I had a listing with another prominent Broker. After eleven months without a sale, I called Ray. He sold it in about a month! Would I recommend Ray? Yes!"

"In April, I asked Ray Irving to sell my practice. At the same time my friend decided to sell his practice. He employed another firm. My practice sold June 22. My friend's practice still hasn't sold and he was putting his dreams on hold."

PPS of The Great West's reputation is built upon grounded ethics and effectiveness. Our trademark "client services" include accurate assessments, impeccable marketing plans, complete transparency, generating quick responses, realizing multiple Offers, securing 100%+ financing in days, expert papering of our transactions and sound counsel. Everything is done to protect our Client and to effect a successful transfer. Our intent is simply to provide the best service imaginable for this very important engagement.

CA DRE License #1422122

Place a FREE Reader Ad online at www.thedentaltrader.com

Flat Rates – Zero Problems

“Bob completed our incorporations and partnership agreement, Kevin’s original buy-in, and now our partnership dissolution and Larry’s buy-out. At each stage, Bob thoroughly and clearly documented each transaction, was quick to respond to our questions, and completed each at a flat rate with zero problems. We would recommend him in a heartbeat.”

Larry Basham, DDS, and Kevin Miller, DDS.

Robert W. Olson, Jr., APC

Dental Practice Sales & Purchases
Partnerships, Property Purchases & Leases
Corporations & Audit Protection

888.963.1120

RWO@transdental.com

www.transdental.com

#1 Avvo® Rated
Attorney in USA
2011 to Present:

Mergers & Acquisitions
Incorporations