

THE Dental Trader

FREE ADS FOR DENTISTS & STAFF!

VOL. 12 NO. 10 • OCTOBER '15
So. Calif. Edition

Ph: 877-888-4237 • 949-429-6836
Fax: 949-498-1198 • DentalTrader.com

Buy, Sell or Trade all things Dental



Digital Dental X-Ray System Half-Price Special

DIGITAL SYSTEM INCLUDES:

Everything you need for a Digital Exam Room!

Hi-Quality Clio Diagnostic Digital X-Ray Sensor & Intra-Oral Camera, Dell i5 Computer & 22" Monitor with 3 Year Onsite Warranty, External Backup Drive, Surge Protector, Mobile Cart (Pole or Rectangular), EZ 2000 Plus Advanced Practice Management Software & Integrated Imaging Software (or keep your own billing software & we provide bridge for free), Full Blown Color Coded Scheduler, Graphic 3D Movable Tooth Charting, Timeclock, Installation, Onsite Training & Technical Support. Optional Integrated Benefit Service by Trojan Prof. Services, as well as credit card processing and electronic claims.

\$9,995

Regular Price: \$19,990

Or Lease to Buy:

- No Money Down
- No Payments for 90 Days
- \$220 per mo. for 5 years
- \$1.00 Buyout

Visit us online at
www.ez2000dental.com

BBB
A+ Rated



Call for your **FREE**
in-office Demo:
800-273-5033

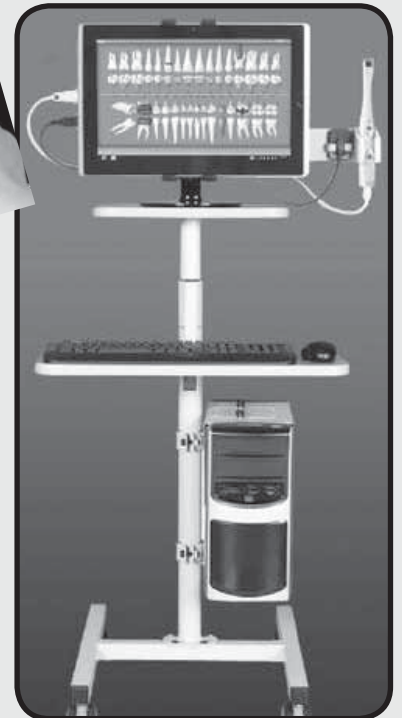

or

Choose Our 3 Exam-Room Ultra Digital System

- Carted Computers as shown in 3 Exam Rooms
- Adult and Pado Clio Sensors w/ClioSoft
- Award-Winning Claris i4D Intra Oral Camera
- EZ 2000 Plus Advanced Prac. Mgmt. Software
- Backup drive, surge protectors
- Sheaths & Positioners
- Onsite installation, Training

\$19,995

Regular Price: \$39,995

Or Lease to Buy with

- No Money Down
- No Payments for 90 Days
- \$440 per month for 5 years
- \$1.00 Buyout

* Cat5 Network cabling extra



Already Have a Digital System and Billing Software?

Upgrade to the
Award-Winning

Claris i4D

- Ultimate Everyday Intra-Oral Camera
- Sony CCD Sensor
- Clearer Image
- Expertly Engineered
- 2 Year Warranty



Reg: \$3,995
Sale: \$2,750



WOOD AND DELGADO

- Legal Advisors to over 15 Dental Societies
- The Chosen experts on Business Transactions for Dentaltown
- 180+ Dental Practice Transitions in 2014
- Providing service to clients NATIONWIDE

Specializing in

Practice Acquisitions/Sales, Partnerships, Business Transactions, Lease Negotiations, Estate Planning & Transitions

HOW DOES YOUR PRACTICE TRANSACTION ATTORNEY STACK UP?...

REGISTER TODAY!

for our Annual Seminar
"Navigating the
Dental Transition
Minefield"

October 30th, 2015

COMPLETE REGISTRATION
FORM IN THIS ISSUE!

Call today for a free phone consultation



800-499-1474



www.DentalAttorneys.com

PATRICK J. WOOD & JASON P. WOOD
ATTORNEYS AT LAW

Wells Fargo Practice Finance

WELLS
FARGO

Financing your practice — and so much more



Learn how our financing programs, business planning resources, and professional support can help you reach your practice goals.

Call us for a complimentary consultation.

Sina Mansouri **Kris Nishihira** **Jason Schneller**
1-855-544-0245 1-855-405-2107 1-888-220-7321

Or visit us at wellsfargo.com/dentaltrader.

ADA Business ResourcesSM

Wells Fargo Practice Finance is the only practice lender selected especially for ADA[®] members and endorsed by ADA Business ResourcesSM.

All financing is subject to credit approval.

ADA[®] is a registered trademark of the American Dental Association. ADA Business ResourcesSM is a service mark of the American Dental Association.

ADA Business Resources is a program brought to you by ADA Business Enterprises, Inc., a wholly owned subsidiary of the American Dental Association.

© 2015 Wells Fargo Bank, N.A. All rights reserved. Wells Fargo Practice Finance is a division of Wells Fargo Bank, N.A. ECG-1361502

Together we'll go far



Advanced Zoom Whitening lamp for sale. Works like new. \$550
OBO 310-994-5336.

Specialist needed for new office in Irvine spectrum. Please, fax
9495527900.

Dental Buffalo No. 1A Vibrator. Never used. \$70. OBO 949-
202-4420 or email.

ENDODONTIST needed 1 day a month in our Carson office.
Please email to caredental4you@gmail.com.

DUST COLLECTOR 60U By Handler Mfg. Never Used. \$550.
OBO. 949-202-4420.

BRAND NEW NSK Variosurg System \$8000. marknoori@gmail.com
310-295-7255.

Wall mounted Siemens x-ray(Heliodont)\$1800. Call (714)848-
8433.

Endodontist available Please email sparklew2k@yahoo.com.

PRIVATE PRACTICE LOOKING FOR A GD MUST SPEAK
SPANISH, P/T, POMONA, FAX (909)784-1768.

Irvine spectrum dental space avilabel For share or lease.
Contact fax: 9495527900.

Fastbraces bracket and wire kits (4) \$700 each or \$2000 for all
4. 310 650 0091.

Dental Office for Sale in Anaheim 4 unit office. Email me at
ktisbs@yahoo.com.

General Dentist Wanted for Tustin office. New Graduates
Welcome. Please call 818-317-8340.

Handler Chuck/Changer w /Lathe Model 16BN. Never used.
\$550. OBO 949-202-4420.

PLACE A FREE AD TODAY! See FAQs page at dentaltrader.com.

Looking for an orthodontist for our practice-please call Judy at
310-785-0770.

FOR SALE Finishing Strips from MOYCO. \$9. Email for pic-
tures. gaw1177@gmail.com.

X-ray film mini max \$\$\$ 17.0 408-981-5069 David
Davidnader777@yahoo.com.

P/T DA Needed (Northridge area) bilingual Spanish a must
Send resume to dream9411@gmail.com.

Receptionist needed in Wilmington Email Resumes to
fshadaieedental@yahoo.com.

Perfect Apical Seal With Life Time Warranty For ALL Inoperable
Endo. I Provide Everything. visit: www.socalrootcanal.com.

Implants for sale 3itapered ossteotite, 6x10, 6x13, (3)5x13, 4/3x10.
\$300 each or \$1500 for all. 310 650 0091.

Board eligible Endodontist is available to help you with difficult
root canals. Please contact nadiyatabachnik@yahoo.com.

CT Machine Newtom Model 9000 For Sale Great Condition
\$7000.00 Perfect for implants! 951-359-9100.

**THE TRUSTED
BROKER SINCE 1994**



Paul Maimone Broker/Owner
CA Broker #01172430

**CA REPRESENTATIVE FOR THE NATIONAL
ASSOCIATION OF PRACTICE BROKERS (NAPB)**

KERN COUNTY

BAKERSFIELD #29 - PRICE REDUCTION! (4) op comput. G.P. (3) ops eqt'd, (4th) plumbed. Located in a free stand bldg. Cash/Ins/PPO/HMO pts. Digital x-rays. Annual Gross Collect \$300K+ on a part time schedule. Seller is moving and is motivated.

BAKERSFIELD #30 - (6) op computerized G.P. (5) ops eqt'd/(6th) plumbed. Absentee owned. Located in a shop ctr. with exposure/visibility/signage and excellent parking. Many walk ins. Cash/Ins/PPO/Denti-Cal pt base. 2014 Gross Collect \$460K+. **NEW**

So. KERN COUNTY - PRICE REDUCTION! (6) op comput. G.P. located in a Bakersfield suburb in a small strip ctr. with exposure/visibility. Pano eqt'd. Limited competition. Cash/Ins/PPO/HMO Denti-Cal pts. Annual Gross Collect. approx \$350K part time. Seller is moving and is motivated.

LOS ANGELES COUNTY

ARCADIA - (4) op computerized G.P. located in a well known Prof. Bldg. on a main thoroughfare. Cash/Ins/PPO pts. Annual Gross Collect \$300K+ on a (3) day week.

LOS ANGELES - (3) op computerized G.P. located in a Landmark Medical/Dental Bldg. on a main thoroughfare. Cash/Ins/PPO pt base. No HMO and No Denti-Cal. Digital X-rays. Annual Gross Collections \$600K+.

MONTEREY PARK - PRICE REDUCTION! (6) op fully equipped computerized G.P. Located in a store front on a main thoroughfare with exposure, visibility & signage. Digital x-rays. Annual Gross Collections \$250K+ on a part time schedule. Cash/Ins/PPO pts. Seller is retiring but will assist with the transition.

SHERMAN OAKS #4 - PRICE REDUCTION! (3) op comput G.P. located in a well known medical/professional building on a main thoroughfare. Cash/Ins/PPO patient base. Annual Gross Collect of approx. \$160K on a (3) day week. Great starter, satellite or buy and combine opportunity. Seller retiring.

ORANGE COUNTY

SANTA ANA - Absentee owned (6) op fully equipped G.P. located in a smaller two story building on a main thoroughfare. First floor street frontage with exposure/visibility/signage & parking. Cash/Ins/PPO patient base with no HMO and no Denti-Cal. Computerized and Pano equipped. 2014 Gross Collections of \$549K+ on a (3 1/2) to (4) day Associate run week.

TUSTIN - (4) op TURNKEY OFFICE with some included charts. (Charts included, but not guaranteed). (3) ops eqt'd/4th plumbed. Office located in a busy shopping center, on a main thoroughfare, with exposure/visibility/signage and ample free parking. Newer high end buildout with new tile flooring, Italian leather dental chairs, digital x-rays, networked, fully instrumented, etc. Computers and Dental s/w also included in the sale.

RIVERSIDE COUNTY

SOUTHWEST RIVERSIDE COUNTY - (5) op computerized G.P. (4) ops eqt'd/(1) additional plumbed. Located in a smaller prof. building in a condo which is also available. Cash/Ins/PPO pts. No HMO and no Denti-Cal. (14+) years of Goodwill. 2015 Projected Gross Collections of \$400K+. Seller is giving up private practice for an institutional position.

D&M SERVICES:

- Practice Sales & Appraisals
- Expert Witness Court Testimony
- Practice Search & Matching Services
- Medical/Dental Bldg. Sales & Leasing
- Practice & Equipment Financing
- Pre-Death and Disability Planning
- Locate & Negotiate Dental Lease Space
- Pre-Sale Planning

SANTA BARBARA COUNTY

CENTRAL COAST/WINE COUNTRY - (3) op comput G.P. & 1,900 sq ft free standing bldg. for sale. Bldg. houses the dental office and a residential unit. Live in unit or rent it out! "Fee for Service" Practice. No HMO, PPO, or Denti-Cal. 2015 Projected Gross Collect \$280K part time. Growth potential. Seller refers all specialties and does little advertising. Seller retiring but will assist with Transition. **See full page ad for this opportunity on page 71 of this issue. NEW**

SAN BERNARDINO COUNTY

RANCHO CUCAMONGA - (4) op comput. G.P. located in a large shopping ctr with excellent exposure/visibility/signage & ample free parking. Modern equipment and digital x-rays. Gross Collect \$586K in last (12) mos. Cash/Ins/PPO/Denti-Cal pts. Low overhead office. Excellent growth potential. Seller refers diff. Endo and most surgeries and does no advertising other than website. **NEW**

SAN DIEGO COUNTY

Room for Your San Diego County Practice Listing.

SAN LUIS OBISPO COUNTY

GROVER BEACH - TURNKEY OFFICE. (2) ops of newer eqt. Digital x-ray and Pano. Computerized and networked. Dentrix s/w & Shick sensors. Located in a strip center on a main thoroughfare. Exposure/visibility and signage. Very low rent. Priced less than build out costs. Will go quickly. **NEW**

VENTURA COUNTY

CAMARILLO - (3) op comput. G.P. (2) ops eqt'd/(3rd) plumb. Located in a large strip ctr. with signage & ample free parking. Older eqt. 2015 Gross Collect projected @ \$125K+ part time. Cash/Ins/PPO pts. Low overhead office. Excellent growth potential. Seller does no advertising. Priced below build out cost. Seller retiring. **NEW**

OXNARD - (4) op comput. G.P. Located in a prof. bldg. with ample free parking. Dentrix s/w & digital x-rays. 2014 Gross Collect \$264K+ on a (3) day week. Cash/Ins/PPO/HMO/Denti-Cal pts. Seller refers diff. Endo & O.S., all Perio & Ortho. and does no advertising. Seller taking non profit position. **NEW**

UPCOMING PRACTICES FOR SALE

Anaheim, Beverly Hills, Central Coast, Culver City, Fountain Valley, Glendale, Glendora, Laguna Hills, Los Angeles, Mission Hills, Montebello, Murrieta, Palmdale, San Fernando Valley, San Gabriel, Santa Clarita Valley, Temecula, Thousand Oaks, Torrance, Ventura Cty., Visalia & West Covina.

D&M "The Personalized Service
Dental Broker[®]"

P.O. Box #6681, Woodland Hills, CA. 91365

(866) 425-1877 Outside So. CA

or (818) 591-1401

www.dmpractice.com

LCF Financial Services

A Division of LCF Financial, Inc.

*With over 20 years of experience,
LCF is able to offer financing for all of your practice needs.*

100% Practice Financing!
100% Real Estate Financing!

Call Today for a Free Consultation!

Toll-Free: 1.800.550.9228
Email: Practice@lcfinc.com

Direct Line: 1.714.550.7494
Website: LCFPracticeSales.com

Surgeon 5 years of experience available to come to your office. Flexible schedule/weekends. Email me laoralsurgeon@gmail.com.

Westlake village Seeking partner dentist for amazing high tech practice in with 10+ years goodwill. 818-455-3321 or dentistador@gmail.com.

DDS needed P/T or F/T in Palmdale, CA. 2-5 yrs exp pref. Send cv to palm smile@yahoo.com attn: Donny.

Glendale/Montrose area family dental practice is looking for an outgoing and organized RDA for 4 days per week. Please email your resume to: kenriques2648@gmail.com.

The Best Kept Secret in Cosmetic Dentistry Limited opportunity for 10 dentists to add \$150k or more net working as little as 1 additional hour per day. I am doing it and so can you. For more info go to www.easysmileveneerssandiego.com or text 760-583-9200.

PRACTICE SALE VALENCIA. Retirement. Established general dental practice. 4 operatories. Average collections \$300,000+ on part-time 3 days/week. Seller motivated. Broker - Charles Kim 800-416-2055.

Experienced GD Bilingual English/Spanish. Tuesdays. High volume of patients. Wisdom teeth, implants, Root canals. Will bring Hygienist. Email ofernandez539@gmail.com.

ORTHODONTIST in your practice Experienced, UCSD UCLA graduate, Faculty member, GREAT COMMUNICATOR, long term commitment Bio at saperorthodontics.com drcsaper@gmail.com 646-334-0100.

Dental Hygienist to work Saturdays needed (Oxnard). Fax your resume to (805)204-0973 or email to: FolmsbeeDental@gmail.com or call (805)436-7949.

Experienced and proficient General Dentist in Root canal Treatment and crown bridges available Part times please contact caring dds@aol. Com.

Looking to rent office space in DTLA or Beverly Hills to start Orofacial Pain practice. potter@usc.edu Schick CDR sensor size 2. Comes with calibration disk and box. Almost brand new! Excellent condition. \$3000 Email: Dentalstaff2013@gmail.com.

FOR SALE Instruments typodont cassettes burs hoes files and recapper MSG davis154@mail.chapman.edu.

Need a dedicated positive, detailed-oriented FRONT OFFICE. Santa Monica GP. PPO, Care Credit, treatment plan presentation, good phone skills. smtoothdr@gmail.com.

\$1000 Rebate on Dry Vacuum System, \$3995 update your old vacuum system to New Drought Tolerant Standards. Made in USA. Call (800) 423 - 5657 for more details.

For Sale Sleep Test Equipment: -Acoustic Rhinometry System -Acoustic Pharyngometry System -Pharyngometer Wave Tube -2 Watermark Ares Unicorders Brand New, Only been used for training. Comes with all manuals and required components. Please call (310)273-2215 or email info@arthurglosmandds.com asking price \$20,000/OBO.

Need a Practice Transition Attorney?

Hire the Best.

29 Years Experience
Unmatched Credentials
Pragmatic Advice
Reasonable Fees

"Thank you for a fantastic job you did in helping me handle my practice transition, especially on such short notice. You were very professional, extremely timely and helped me achieve ownership of an incredible practice. I would highly recommend you to any dentist who needs legal counsel as someone who helps get the job done in a seamless manner. Although we did not even meet face to face, it was a pleasure to work with you."

David Buchan, DDS, San Clemente, CA

**#1 Avvo® Rated Mergers &
Acquisitions Attorney in USA**

USC Law 1984

Dartmouth College 1981



Robert W. Olson, Jr., APC

**Practice Sales, Partnerships,
Real Estate Sales, Corporations,
Leases & Lease Review.**

888.963.1120

RWO@transdental.com

www.transdental.com

“YES DOCTOR, YOUR LOAN IS APPROVED.”

Not hearing that from your current lender? We can help.

We look at the total financial package. We have more latitude with terms and rates than the “big banks”. We are not burdened with corporate red tape and are able to fund our loans locally and quickly.

Why Wait? Call Howard Boles today.
949.379.5704
hboles@ocbusinessbank.com



**Orange County
BUSINESS BANK**

1/15



Orange County Business Bank Professional Practice Finance

- Practice Acquisitions
- Partnership Buy-ins/Buy-outs
- Refinance & Debt Consolidation
- Office Expansion/Relocation
- Working Capital
- Equipment Purchases

949-221-0001

www.ocbusinessbank.com

17901 Von Karman Avenue, Suite 100, Irvine, CA 92614

List your practice with the professionals, don't leave thousands on the table, know how to maximize your value, call Henry Schein PPT - Steve Caudill 951- 314-5542.

Cecilia Chen, Esq negotiated a 3-months rent abatement for my practice purchase, giving me the much needed capital during the transition period. – D. Aminov, DMD.

Greg Beamer, Dental Broker 909-542-4891. The Name You Know, The Reputation You Trust. Providing Exceptional Service to both buyer and seller Greg Beamer, Dental Broker 909-542-4891. Full Service Brokerage with 22 Years of Experience.

Are you paying too much for dental malpractice insurance? Find out immediately with a quick quote from PSIC. NO ASSOCIATION FEES!
www.psicinsurance.com/dentists.

DENTAL PRACTICE FOR SALE IN SALINAS Gross ~\$270K. Large retail shopping center. 3 ops. #SL32R. Loc Pham, Broker at LCF Financial, Inc. BRE #01875780, (714) 550-7494 or practice@lcfinc.com | LCFPracticeSales.com.

Dental asst needed Tues, Wed for Laguna Hills private practice. Send your resume to alicidental@gmail.com or call 949-770-7077.

CENTRAL COAST/WINE COUNTRY (3) op comput G.P. & 1,900+ sq ft free standing bldg. for sale. Bldg. houses dental office & residential unit. Live in unit or rent it out! “Fee for Service” pts. 2015 Projected Gross Collect \$280K part time. Growth potential. Seller refers all specialties & does little advertising. Seller retiring but will assist with Transition. D&M Practice Sales 818.591.1401.

Looking for Oral Surgeon 1-2 Fridays a month in Glendora. sandimasdental@gmail.com.

Is it time to consolidate your loans? Let's talk about how we can work together to simplify your finances. Call Wells Fargo Practice Finance at 1-888-937-2321 or visit us at wellsfargo.com/dentaltrader.

FOR SALE Kilgore Typodont. Dental Study Model. Used for dental school. \$80. Email for pictures. gaw1177@gmail.com.

DENTAL PRACTICE FOR SALE DELANO: Single user building. Absentee owner. Huge growth potential. Bldg Available. Call Broker - Practice Sales & Appraisals (818) 999-9595.

Whittier Private Pediatric dental office for sale. Great 1st office or satellite office. Collects +\$200K/year.1 day/week. Contact becharmusa@yahoo.com.

Holistic Practice San Diego: Large and very profitable. Wonderful loyal patients. More details provided upon request. Ken Rubin Practice Sales (619) 299-6161.

Doctor/assistant stools (4 each), waiting rooms chairs (8) in good condition for sale. Call will send pictures (909)9101688.

In-Office Equipment Repair 50% OFF FIRST HOUR Friendly. Prompt. Professional. Honest. Contact Us Today! 877-535-1733 / www.repairmakers.com.

OFFICE FOR SALE IN NORTH HOLLYWOOD. 4 fully equipped operatories. Only \$190,000. Call (818)442-1715 Dr. O.



San Diego Practice Sales

*SAN DIEGO'S MOST EXPERIENCED,
TRUSTED & ACTIVE BROKER (since 1990)*

We have sold HUNDREDS of Practices totaling several MILLIONS of Dollars!!

VISTA--JUST LISTED!! GENERAL Practice situated in Retail Center along VERY busy thoroughfare. 4 Ops (3 equipped) in approx. 1400 sq.ft. ALL Digital and Paperless! Dentrix Software. Panorex. All Insurance and Cash Patients.

RANCHO MIRAGE--JUST LISTED!! Doctor retiring from estab. **GENERAL** Practice situated in Busy, Upscale retail center. 4 Ops in 1500 sq.ft. Pan-Ceph. Owner refers out LOTS of dental care!

OCEANSIDE--Equipment and Leasehold Improvements. 3 ADEC Ops (1 more plumbed) in 1375 sq.ft. Introral Cameras, Panoramic, Digital X-Ray, Rotary Endo, and more. Owner leaving country. VERY low price for quick sale!!

CARLSBAD-- This **GENERAL** Practice was estab. in 1996. All Insurance and Cash. 5 equipped Ops in 1500 sq.ft., freestanding dental building. Recently expanded and updated facility. Digital X-Rays. Excellent lease.

MIRA MESA--- 20+ year **GENERAL** Practice has 4 Ops in approx.. 1300 sq.ft. Situated on corner of busy intersection. Primarily PPO.

LEMON GROVE- GENERAL Practice in high traffic strip mall. 4 Ops in 1100 sq.ft., has digital. Cash, PPO, Cap. Absentee owner.

VISTA—FOR LEASE. Approximately 2650 sq. ft. of divisible ground floor space. Situated in highly visible medical-dental bldg. along highway 78. Previously occupied by dental practice. Generous tenant improvement allowance, flexible terms and affordable rental rates.

for updates, please visit us at

WWW.SDPRACTICESALES.COM

SAN DIEGO PRACTICE SALES can also assist you with PRACTICE APPRAISALS, BUY-IN BUY-OUT TRANSACTIONS and LEASE NEGOTIATIONS.

For More Information Call:

Mike Hostler (760) 599-7828 Bob Fleming, D.D.S.
(voice mail)
SERVICE — INTEGRITY

DENTAL LAW LITIGATION ATTORNEYS

*Over 19 years of in court experience, with hundreds of dentists
and over 35 hospitals represented*

**Loan Issues • Buy/Sell
Real Estate • Partnership
Buy/Sell Agreements
Lease/Real Estate • MSOs
Contract/Business
Partnership/Employment
Lawsuits/Defense**



Shab David Kerendian, Attorney

"Kerendian & Associates has represented me in over 25 matters in court or arbitration against insurance companies. They are responsive and caring. I am very satisfied."

-James H.I. Bicher, M.D., Oncologist, Valley Cancer Institute, Los Angeles, Ca.

"I saw Mr. Kerendian argue the case in court, and was greatly impressed. I highly recommend him."

-Peiman Soleymani, D.D.S., Periodontist Los Angeles, Ca.

"Having been represented by Mr. Kerendian many times, I was impressed with his expertise, quick response to questions, and degree of care."

-Mark Davidson, M.D., Los Angeles, Ca.

"I have been working with Mr. Kerendian, and he has shown utmost professionalism and devotion to me."

-Dan P. Benyamini, D.D.S., Family Practice, Los Angeles, Ca.

KERENDIAN & ASSOCIATES ATTORNEYS AT LAW

Free Consult Over the Phone • Flat Fee Packages Available

11755 Wilshire Blvd., 15th Floor, Los Angeles, Ca. 90025

Ph: 888.299.7848 • shab@kalawcorp.com • 310.914.4143 • Fax: 310.914.5441

9.15

Buying A New Practice Call Bob Affleck for your practice financing needs 949-939-4550.

PRACTICE SALE LAKE FOREST (Orange County). Retirement sale. Established general dental practice. Street visible retail center. Low rent. 3 operatories. Broker - Charles Kim 800-416-2055 & #8203; & #8203.

DentiMax Dream Sensors Try before you buy. Test our award winning sensor in the comfort of your own practice without any obligation. Call 1(800)397-6046.

PRACTICE FOR SALE NEW!! GP in VISTA along VERY busy street. 4 Ops (3 equipped) in 1400 sq.ft. DIGITAL & PAPERLESS. Panorex. Insurance and Cash. SDPS: 760-599-7828.

Dental Assistant position in Orange. send letter of interest and CV in pdf format to Careers@SmileMore.guru.

Thomas Sudbijo, DMD (Tustin, CA)-Law Offices of Jeng and Associates is definitely one law firm that I will continue to use for my legal needs. Dr. Jeng was very helpful addressing my questions and was on top of things and kept me informed in every step. Call Jeng & Associates 714-858-0536.

Professional Services over \$50 Million loaned to Southern California Dentists. NEED MONEY? We've GOT IT. Call Sunwest Bank 714-730-4412.

Dental office for sharing, low cost, many parking spaces, San Gabriel, 3D cone, pano & Ceph x-Ray available. (626) 478-8813.



In an industry that is changing constantly, wouldn't it be nice to find a banker that understands the needs of your practice? A bank with a team of professionals who can deliver solutions to help meet both your short-term and long-term goals. At Sunwest Bank, having an in-depth understanding of the needs and goals of your practice is fundamental to the way we work with you.

Loan Products and Services:

Commercial Real Estate Loans and Refinances
Practice Acquisitions
Refinancing Your Practice Loans
Equipment Financing
Partner Buy-in and Buy-outs
Practice Expansions (Multiple Locations)

Deposit Accounts and Services:

Online Banking
Remote Deposit
Visa/ATM Cards
Wire Transfers
Merchant Card Processing
ACH
Zero Balance Accounts

For more information contact:

Jim Martin

Senior Vice President
Practice Finance Specialist
714.730.4496 direct | jmartin@sunwestbank.com



SUNWESTBANK.COM

REGENT GRADS DENTAL OFFICE EQUIPMENT FOR SALE. 2 CHAIR UNITS, XRAY, SUCTION, COMPRESSOR, AUTOCLAVE, MUCH MORE. ONLY \$19,900. 818-591-0123 BUENA PARK LEASEHOLD SALE ONLY, NO PATIENTS. BUSY STREET, NEAR KNOTT'S BERRY FARM. CALL: 714/9959301 EMAIL: ctmagana01@yahoo.com.

Registered Dental Assistant for San Fernando Valley non-profit clinic, bi-lingual Spanish, pay \$15-\$20/hr resume 818-998-3579 or email hr@mccn.org.

Don't sign your office lease without knowing what's in it! Talk to a skilled dental attorney regarding the ins and outs of your lease. Levi Barlavi. (310) 776-5384 www.dental-attorney.com.

Associate Dentist We've built thriving, quality oriented South Bay Practice. Single location dentist owned practice, not a chain. * Diagnose and treat own patients * Focus on what you do best DENTISTRY * Have 3 RDAs or RDAEFs * No Hygiene or Peds * We have in-house specialists 80% patients PPO/private. Experienced staff - 15+ years. Compensation \$600 a day plus bonus. email Hawthorndentist100@yahoo.com.

PRACTICE FOR SALE APPLE VALLEY GP w/37 yrs gdwill; \$44K/mo California Practice Sales, Inc. Phone: 714-639-2775.

A-DEC 511 Patient Chair (Cost \$11,189) 611 Doctor's stool (Cost \$809) Like New, Make Offer. 855-772-7645 or janetm@hygiacare.com.

PT/FT position available for GP at huntington park. New grads welcome! Email kimjoel@gmail.com to apply.

Looking to finance a practice? Contact Live Oak Bank. Our specialized lenders will build a customized loan to meet your financing needs. 877.890.5867 www.liveoakbank.com/healthcare.

Got the Denti-Cal blues? Let's face it, Denti-Cal is a complicated and challenging dimension of dentistry...don't go it alone. Let Kerendian & Associates guide you. 888-299-7848.

Experience and Ethics counts when Selling your Dental practice -if you are considering selling your practice, call Greg Beamer, Dental Broker 909-542-4891.

All County Construction We're Building your Future. YOUR satisfaction is OUR main priority. Call Today 714-240-7179.

FRESNO Priced to sell. Great retail location with easy parking and 6 ops. Ready for a busy dentist. IntegrityPracticeSales.com, Broker Bill Kimball, DDS, BRE #01911548. (855) 337-4337.

40 OBTURATORS WITH BRAND NEW OVEN \$195! Free Shipping! Will Deliver and Demo in Los Angeles County. For pictures:profitableGPs@hotmail.com. (310) 699-3441.

"Hi Mr. Wood Just want to drop a note to say thank you. You gave lots of great advice, and shared Many Pearls of Wisdom in Your Seminar I attended. Once again, thank you very much!" JULIE HSIEH, DDS Tarzana, California. WOOD & DELGADO www.dentalattorneys.com.

GP office looking for an associate to join Riverside dental office. 1-5 years dental experience preferred. Send resume to drmehta01@yahoo.com.



PRACTICE SALES & APPRAISALS

We are pleased to present . . .
These outstanding practice opportunities

ANAHEIM: Over 19 years of Goodwill. Turnkey Opportunity. Busy Shopping Center.

DIAMOND BAR: Shopping Center. Super Look 4 Ops. Retiree. Big upside.

DOWNEY: Pre-Approved for 100% Lender Financing. Shopping Center with Visible Sign.

ENCINITAS: Shopping Center. Beautiful Facility. Revenues \$35k/mo. Absentee Owner.

GLENDORA: Retiree with Private Practice. Low Overhead. Excellent opportunity.

HISPERIA: Retiree. Shopping Center. Very Neat. Low Overhead. Huge Upside!

IRVINE: Long Established Private Practice. Active Hygiene Schedule. Seller Retiring.

LOS ANGELES (West): Private Practice. Seller Retiring. Low Overhead.

LOS ANGELES (Downtown): Major Sign Visibility. Seller Retiring. Growth opportunity.

LOS ANGELES: Shopping Center. 4 ops. Gross of \$35k/mo on Part-time Schedule.

MONTEREY PARK: 1st floor. Visible. Clinic. Absentee Owner Opportunity.

NORTHRIDGE: Retiree with 20+ years goodwill. Free Standing Bldg. Huge Upside!

PALMDALE: Retiree. 20+ years of Goodwill. HMO income of \$5K/mo. Priced Right.

REDLANDS: Private Practice. Over 40 years of Goodwill. Ideal Starter Practice.

SANTA BARBARA: Busy Practice. Seller Retiring. Sale Price under \$400K.

SF VALLEY: Profitable w/20 years of Goodwill in North Valley. Hispanic Patients.

SANTA CLARITA: Hi-End Private Only Practice. Modern Facility & Equipment. Must See.

TORRANCE: Busy Shopping Center. Proximity to Freeway. Low Selling Price.

VALLEY VILLAGE: Long-established Practice with significant Upside Potential.

VAN NUYS: Must See Shopping Center Opportunity.

VICTORVILLE: Retiree. Quality Oriented. Transition.

Listing in Other Areas We are Processing

Hemet, La Jolla, Lancaster, Modesto, Montclair, Ontario, Oceanside, Temecula, San Jose

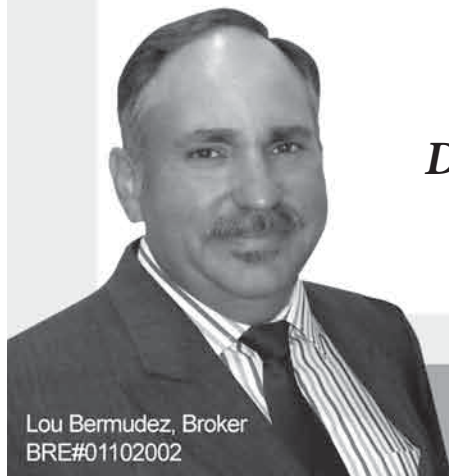

Lou Bermudez, Broker
 BRE#01102002

*Dental Practice Brokerage and Appraising
 for Over 30 Years*

PHONE: 818.999.9595
www.ddspracticesales.net

Want a Dramatic Practice Face Lift?

No job too big or
too small....we do it all.
Best rate you'll get!

Now is the perfect time
to do Tenant Improvements!
Transform your practice into
a functional work of art.
We've designed some of
the most beautiful dental
offices in California.



DESIGN/BUILD
Plan and Permit Services
T.I.'s - Remodels - Expansions
Free Standing Buildings
Turn-Key Packages
Consultation
Free Estimates

**ALL
COUNTY
CONSTRUCTION**
Bradley Jordan Construction Co., Inc. dba All County Construction

Lic. #669244

562-989-3350

E-mail: jcardio@aol.com

www.allcountyconstruction.com

Jim Jordan: 714-240-7179 Cell

San Diego Practices for Sale

Holistic Practice - San Diego: Large and very profitable. Wonderful loyal patients. More details provided upon request.

North County San Diego: 4 Ops. GP Practice with Prosthodontics emphasis. 75% Fee For Service. Low Overhead. Nice looking office.

Vista: 6 Ops. 1,500 Sq. ft. 26 yrs. of Goodwill. Office Condo for sale also. Seller retiring. Located in Professional bldg.

Endodontic Practice: North County Inland. Very nice State-of-the-Art practice. Phenomenal growth potential. 3 Ops. Must see to appreciate. Opportunity to buy building also. Bargain Price for quick sale.

Chula Vista/Eastlake: Office Condo also for sale. Great location in professional medical building. 20 years of goodwill. Mainly PPO and Fee for Service, no HMO. Beautifully appointed office.

Downtown San Diego: 6 Ops. 3 Equipped. Located by Petco Park. Bay views. Room to expand with extra ops. Large brand new residential planned development close by. Practice has Panoramic, digital X-ray, and intra-oral cameras.

Ocean Beach: Prime high visibility corner located on Ocean beach's busiest street. Very low overhead with no marketing being done. 35 years of goodwill. Fee for service and PPO only. Only four blocks from popular San Diego beach.

Mission Valley: High production/High profit office. Great location in busy shopping center. Freeway close.

View our website for current listings at: www.KRpracticeSales.com

SELLERS: Ask us about our Risk-Free 30-day Listing Agreements!



Ken Rubin Practice Sales, Inc.

4420 Hotel Circle Ct. Suite 350

SAN DIEGO, CA 92108

(619) 299-6161



Ken Rubin

Jonathan Ingalls

10.15

Free Dentists Stool (\$325 Value) with the purchase of an Assistants Stool for \$450. 100's of Color Choice's. Made in USA Call (800) 423 - 5657 for more details.

ENCINO private office with views, Associate eventual buyin/purchase within one year, 4years experience. Reply thedentalcenter1@gmail.com.

Entire Ortho Office Equipment 4 Sale in So Cal: Chairs, lites, compressor & much more; excellent condition; 949-633-8264 leave message.

RESEDA PEDO 2 treatment rooms & 3 junior chairs in an open bay in 1,355 sq. ft. suite. 57 Years of Goodwill. Retiring Seller. Easily converted to an Ortho/ Pedo combination. Excellent Price! Greg Beamer, Dental Broker 909-542-4891.

Temp DA/RDA needed for private office in San Fernando Valley. Pay based on experience. Email resume to drmarshall@newsmilesstudio.com.

La Mesa General Dental Office looking for PT-Associate Dentist please email resume to info@javadisiles.com or fax to (619) 464-2323.

Well established practice looking for an experience dentist to integrate into a long term position. One to two days, leading to more days over time. General practice with great patients and staff. email:contact@indianwellsdental.com.

Camarillo DDS/HMO-PPO, growing area, 2-3yr exp. Very friendly, start 2-3 days. Contact thedentalcenter1@gmail.com.



KINGS TWO DENTAL SUPPLY

NOW HIRING

SERVING DENTISTS FOR OVER 20 YEARS

OPERATPRY PACKAGE	<p>Bel20/Engle Package Includes: Engle Dental Light Engle Delivery Unit Belmont 20+ Chair Call for Price + Free Doctor Stool</p>		STERILIZER	<p>Tuttnauer <i>The Most Reliable Sterilizer in the Market</i> Call us Today for 3rd Q. Promo</p>	<p>STATIM G4 <i>Fastest Sterilizer in the Market</i> Call us Today for 3rd Q. Promo</p>
	VACUUM	COMPRESSOR		DIGITAL X-RAY	<p>BEL-RAY 097 Call us Today for 3rd Q. Promo</p>
<p>JDS VACUUM PUMP WET RING VACUUM PUMP Call us Today for 3rd Q. Promo</p>			<p>TECH-WEST VACUUM LIQUED RING VACUUM PUMP Call us Today for 3rd Q. Promo</p>		<p>CustomAir VACUUM WATER RING VACUUM PUMP Call us Today for 3rd Q. Promo</p>
AUGUST SPECIALS	<p>JDS COMPRESSOR Available in Oil-less or Lubricated Call us Today for 3rd Q. Promo</p>	<p>TECH WEST COMPRESSOR Available in Oil-less or Lubricated Call us Today for 3rd Q. Promo</p>	<p>CustomAir COMPRESSOR Ramvac Call us Today for 3rd Q. Promo</p>	<p>AirStar COMPRESSOR Top Quality Compressor Call us Today for 3rd Q. Promo</p>	
	<p>ScanX Classic Convert your film base Pan/Ceph to Digital Call us Today for 3rd Q. Promo</p>	<p>DENT-X EVA Sensor #1 or #2 Sensor W/Docking Station & Software Call us Today for 3rd Q. Promo</p>	<p>VATECH EZ Sensor #1, #1.5 or #2 Sensor W/Docking Station & Software Call us Today for 3rd Q. Promo</p>	<p>Papaya 3D Digital Pan/Ceph 3D Digital Panoramic X-Ray System W/Software Call us Today for 3rd Q. Promo</p>	
<p>I-Root Apex Locator Introductory Offer.....\$599.00</p>	<p>Advance Cam USB Intra-Oral Camera System \$595.00</p>	<p>Woodpecker UDS-K Piezo Scaler 45 Free Tips.....\$269.95</p>	<p>ART M1 Scaler Ultrasonic Scaler System 25K \$329.00+ 1 Free Inserts</p>	<p>ART E-1 Electrosurgery Unit \$419.00 + 7 Free Electrodes</p>	
<p>Dentmate LEDEX WL-90+ Curing Light + Carries Detector W/Built in Radiometer & 3 Second Fast Cure.....\$449.00</p>	<p>Sonix IV ST144 Ultrasonic Cleaner W/Timer 3.6qt Tank W/Basket \$399.00 +Free Basket & Cover</p>	<p>Endo-A-Class Cordless Endodontic Handpiece \$599.00</p>	<p>Dexcwin EZ Sensor #1.5 or #2 Sensor W/Docking Station & Software CALL FOR PRICE</p>	<p>Digirex PSP Scanner CALL FOR PRICE + 12 Phosphor Plates & Free Software</p>	

OFFER VALID UNTIL 10/31/2015

CALL US TODAY TOLL FREE (800) 715-5464 FAX: 626-581-8137

Buy it! Sell it! Trade it!!!

WHY SEND YOUR ENDO OUT?

I Finish ALL Inoperable ENDO with Lifetime Warranty, Apicos, Retreats, Calcified, Unfound, Unusually Curved Canals, Perfs Repairs, Broken Files.

I PROVIDE EVERYTHING.

20 Years Experience - 1000s Done



**EXCELLENT
RESULTS!**

MIN \$36 K NET
GUARANTEED

Ehab Ismail, DDS

562-968-4061
www.socalrootcanal.com

Panoramic unit Yashida/Dentex Panoura Ultra in good used condition. \$16,000.00 new, \$3,000.00! 661-805-5782 or ehershkowitz@taftcollege.edu.

Experienced periodontist is available to perform all aspects of periodontal surgery, extractions and bone grafting in your office. email mmperio@aol.com.

100% Demineralized Bone Matrix Putty in a syringe .07cc \$85.00 1.0cc \$125.00- these prices can't be beat www.dentalprodx.com.

Selling your practice? Understand potential legal issues with your transition before listing your practice. Free Phone Consultation. Call Levi Barlavi. (888) 776-5384 www.dental-attorney.com.

General Dentist 10+ years experience looking for associate position in SFV/LA area. Proficient in all phases of dentistry. bbkemax@gmail.com.

OFFICE AVAILABLE Mission Viejo / Rancho Santa Margarita. Brand new beautiful office in professional building. Tuesdays, Thursdays, Saturdays. Specialist only. andrewleedds@yahoo.com.

PRACTICE FOR SALE BAKERSFIELD GP 18 yrs gdwll w/ 6 ops Net \$108K California Practice Sales, Inc. Phone: 714-639-2775.

Ortho assistant needed part/full time, must have orthodontic experience and be willing to travel. Main office in Carson inhouseortho@gmail.com.



Thomas & Fees

Practice Sales

"A better kind of practice sales company"

Practices for Sale

Anaheim

Practice and Building for sale - Dr. retiring after 37 years in this location – 3 operatories - Grosses over \$400,000 on 4 easy days/week with low overhead of 55%– fee for service and private insurance. Building consists of 3 separate building on same lot – 1 is 500 sq ft and 1 is 700 sq ft and both are unoccupied and the 3rd building is two dental offices of 1070 sq ft each.

Woodland Hills

Dr. retiring after 38 years in very modern, 8 operator, private practice grossing over \$2.2 million/year. No HMO or PPO's. Huge hygiene with 14 days/week of hygiene. Dr. refers out all endo, oral surgery, and perio. Digital x-rays and Dentrax computer system. A true gem.

Los Angeles

Dr retiring after 44 years in private practice - beautiful, modern 3 operator practice with digital x-rays and ScanX system - very high tech - grosses \$400,000 on 4 easy days/week.

Long Beach

Gorgeous, modern 5 operator private practice for sale in 2500 sq. ft. - 78 year old owner retiring - 4 1/2 days of hygiene – digital x-rays – Grosses almost \$1.1 million/year with net of approximately \$400,000.

Newport Beach

High quality practice for sale. Retiring Dr. does all facets of dentistry including full mouth reconstructions and implants. This practice would be perfect for either a Prosthodontist or General dentist with experience in crown & bridge with attention to occlusion. Grosses \$1.5 million/year on 3 1/2 days/week – 4 days of hygiene.

Laguna Beach

Very modern 3 operator office – digital x-rays with Dexus and Dentrax computer grosses over \$800,000/year with high net income – Dr retiring.

Mission Viejo Ortho

Private orthodontic practice for sale – 3+ operatories in Professional Bldg – Dr retiring after 20 years in same location – collects over \$13,000/mo on 2 easy days per week – Contracts Receivable of \$67,000 included.

Philip L. Kempler, DMD, Broker

Days (714) 544-4341 • Evenings (949) 362-4749

Cell: (949) 395-6000 • FAX (714) 731-7296

Visit our website at www.TFPSales.com

E-mail: Phldr@cox.net

Let one of our dedicated healthcare specialists offer your practice a financial check-up

We provide up to 100% financing with competitive rates and terms for:

- Practice Acquisitions
- Practice Loan & Debt Consolidation
- Expansion/Remodel/Relocation
- Commercial Building Purchase/Refinance



Citi[®] Healthcare Practice Finance Group

Bob Affleck
Senior Vice President
(949) 939-4550
bob.affleck@citi.com

Commercial Bank



All credit applications are subject to bank approval.

© 2015 Citigroup Inc. Citibank, N.A. Member FDIC. Equal Opportunity Lender. Citi and Citi with Arc Design are registered service marks of Citigroup Inc.

Avoided grafts? Referred patients to specialists for receding gum surgery? Not any more! Easy, low impact, low risk technique can be mastered in hours. Visit pinholesurgicaltechnique.com to learn about Pinhole Surgical Technique!

Orthodontist with staff and supplies needed for GP office Pomona to take over existing cases 60% collections inhouseortho@gmail.com.

Never used Root ZX II Apex Locator for \$640 and Endo Elements Motor W/8:1 for \$1240 Henry Schein Invoice Newest 2014 Models Drtom@healthdent.net.

North County San Diego 4 Ops. GP Practice w/ Prosthodontic emphasis. 75% Fee For Service. Low Overhead. Nice looking office. Ken Rubin Practice Sales (619) 299-6161.

Office sublease in Whittier Digital x-rays. Flat screen monitors. only \$250 per day. Includes scheduling service. www.exceptionaldds.com 9495100225.

Newport Beach 2 beautiful operatories for sublease. Perfect for new grads/starters. Flexible terms. contact Behnamlaw@yahoo.com.

BOARD CERTIFIED ORAL SURGEON: 10+ yrs experience. Available in So Cal Area, willing to travel, willing to work weekends. 909-908-9660.

newly built high end office available for sub-lease/option to buy, 3-4 days/week, north glendale/montrose area, 8183700112.

RANCHO CUCAMONGA (4) op comput. G.P. for sale. Located in a busy Shop Ctr. with exposure/visibility & signage. Low Overhead. Newer eqt and digital x-rays. Cash/Ins/PPO/Denti-Cal pts. Gross Collect \$590K+ in last (12) months. Excellent growth potential. Seller does no advertising other than website. D&M Practice Sales 818.591.1401.

Pediatric Dentist Board Certified Wanted - El Monte, CA. Modern office, great staff. 626 444-2605, atlasdentalinfo@gmail.com.

ORAL SURGERY IN YOUR OFFICE (SD/OC/LA areas). Stop referring out. Friendly, experienced Oral Surgeon (DDS, MD) will perform your surgical procedures in your office. Wisdom teeth, implants, sinus lifts/grafting. IV sedation. Will bring assistant, implants, all necessary instruments and equipment. Great with patients. References available. Flexible hours. Please email with any questions. SDOralSurgery@yahoo.com.

Looking for Associate Dentist National City. Base plus incentive, possibility to purchase practice in the future. Experience preferred. Call 619-477-2787.

DENTAL PRACTICE FOR SALE IN COALINGA Gross ~\$589K working 3-4 days/week. Freestanding building. Low Rent! PPO/Cash Only. 3 ops, 1,200 sq.ft. #CL30F. Loc Pham, Broker at LCF Financial, Inc. BRE #01875780, (714) 550-7494 or practice@lcfinc.com | LCFPracticeSales.com.

periodontitis and implant 2 day a month certify, Ontario area ontariofamilydentistry@gmail.com.

When it Comes to the Sale

DENTAL PRACTICES FOR SALE

PRACTICES FOR SALE IN THE FOLLOWING AREAS: Anaheim, Burbank, Encino, Glendale, Hawthorne, Lancaster, Los Angeles, Rancho Mirage, Santa Barbara, Simi Valley, Thousand Oaks, and Woodland Hills.

ENCINO FEE FOR SERVICE PRACTICE FOR SALE: Quality oriented private practice has consistently collected \$1.1 million for the last four years with an equally consistent net income of over \$450,000 per year for the same four years. Seller refers all endo, all perio, all oral surgery and all ortho. Fully computerized four operator office with digital x-rays. No PPO's, no HMO's, no evenings or weekends. Health issues are creating the need to sell. Asking \$850,000. **-PENDING AT FULL PRICE**

ANTELOPE VALLEY CAPITATION PRACTICE FOR SALE: This practice has collected \$1.1 million each of the last three years with an average annual net income of over \$450,000. Cap checks are \$12,500/month. The practice has endo and oral surgery specialties, but no perio, pedo or ortho. The practice averages 78 new patients per month. No Denti-Cal. Profitable practice – a money maker. Asking \$828,000.

SIMI VALLEY GENERAL PRACTICE FOR SALE: Collected over \$700,000 in the past twelve months. Good net income. 3 days of hygiene per week. 4 operator office with digital x-rays and PracticeWorks software. Ground floor of a professional building. Asking \$425,000. – PENDING AT FULL PRICE

ENCINO GENERAL PRACTICE FOR SALE: Established practice collects over \$300,000 on three and a half days per week. Two plus days of hygiene per week. Four equipped operatories. No HMO and no marketing. Seller has medical disability and must sell. Asking \$175,000.

MULTI-OFFICE/MULTI-SPECIALTY PRACTICE: Well known group practice collects \$5.5 million per year. The practice does accept Denti-Cal and is seeing revenue growth in 2015 since adding Denti-Cal to the practice. All specialties are covered. Newer modern offices. Asking \$2,700,000.

WEST COVINA PRACTICE FOR SALE: Starter practice with low overhead. Collected \$200,000 in 2014 and over \$100,000 for the first four months of this year. The practice is in a free standing building and has three equipped operatories plus a fourth that is plumbed but not equipped. Seller works 2-3 days per week as he has a second practice near his home in Glendale with a partner. Motivated. Asking \$120,000.

HUNTINGTON BEACH PRACTICE FOR SALE: Forty plus years of goodwill! Seller works three days per week and has six days of hygiene per week. Refers all endo, all oral surgery, all perio surgery and all ortho. Collects \$350,000 per year with an average net income of \$140,000 per year. Four equipped operatories with digital x-rays. Professional building location. Asking \$250,000. – **PENDING AT FULL PRICE**

HAWTHORNE PRACTICE FOR SALE: Practice currently collects \$250,000/year on one day per week. The practice has 5 equipped operatories with 3 additional operatories that are plumbed but not equipped. The practice is located in a free standing building on a corner on Hawthorne Blvd. with plenty of parking and excellent visibility. Seller wants a quick, smooth transaction. Asking just \$100,000. – **SOLD AT FULL PRICE**

THOUSAND OAKS FEE FOR SERVICE PRACTICE FOR SALE: Well established general practice collects \$525,000 per year on four days per week with four days of hygiene per week and nets \$190,000 per year. Seller refers all endo, all oral surgery, all perio surgery and all ortho. No HMO, no advertising, no evenings or weekends. Seller is retiring after 42 years in practice. Asking \$440,000 - **SOLD**

TUJUNGA GENERAL PRACTICE FOR SALE: Well known practice with long history and good visibility in a shopping center location collects \$820,000/year with a net income of \$340,000/year. Seller works 4.5 days per week and has 4.5 days of hygiene per week. Seven equipped operatories plus one additional operator that is plumbed but not presently equipped. Seller refers all endo, all perio surgery, difficult oral surgery and all ortho. No capitation and no Denti-Cal. Solid "bread and butter" practice in a relatively underserved community in Southern California. Asking \$799,000. – **SOLD**

SAN FERNANDO VALLEY PERIO PRACTICE: Established perio practice collected over \$894,000 in 2014 with a net income of \$285,000/year. Hygiene accounts for 25% of the revenue. Seller works 3 ½ days per week. The office has five equipped operatories in a professional building. The practice receives referrals from over 30 different general dentists in the community. Seller will stay for a transition if requested. Asking \$475,000.

RANCHO MIRAGE COSMETIC PRACTICE FOR SALE: Brand new facility and equipment as of 2012. Very nice build out and quality equipment. Seller moved the practice from a nearby location where he had been in practice since 1991. The practice collects over \$790,000/year with a net income of \$300,000/year. Seller works 4 days per week with 2 days of hygiene per week. Seller refers all implant placement, all perio surgery, all ortho, most oral surgery and most endo. Four ops with full computerization, Dentrix software, digital x-rays, air abrasion and diode laser. Medical issues are forcing the sale. Asking \$425,000. – **SOLD AT FULL PRICE**

LEE SKARIN and ASSOCIATES, INC.
530 W. Stafford Road, Westlake Village, CA 91361
800-SKARIN #1 • 805-777-7707 • Fax: 805-777-0051
Email: lsainc@aol.com • www.LeeSkarinandAssociates.com

- Expert appraisals
- We have a large inventory of buyers
- Over \$20 million in practice sales last year

Serving the dental profession since 1959

of Your Dental Practice . . .

Timing Can Be Everything

LEE SKARIN AND ASSOCIATES...

the Name Dentists have Trusted Most Since 1959.

WOULD YOU BUY A DENTAL PRACTICE WITHOUT SEEING THE FINANCIAL INFORMATION? OF COURSE NOT!

Some dental practice brokers have begun to require a \$10,000 deposit and a signed offer prior to releasing ANY financial information on the practice to the buyer. This is completely unethical. How can a buyer make an informed decision about a dental practice without the financial information? It is equivalent to trying to buy a house without actually seeing the house.

The brokers that engage in this practice often have a high "fall out" rate or offers that never come full circle to consummation of the deal, because more often than not, the actual financial information, when ultimately presented, is not exactly what the buyer expected or what the banks could approve for financing. Admittedly, this sales technique postpones the initial discussion about the practice profitability and financial viability until a buyer has lost money on escrow fees, attorney's fees, and possibly consultant's fee, which increases the buyer's financial loss/commitment, but it does not make that discussion disappear nor does it benefit the seller by getting the deal done. Everyone loses.

As a buyer, you have a right to full disclosure of the practice financial information so that you can make an informed decision. This does not mean that you will not need to sign a confidentiality agreement or that you would have access to the supporting information such as bank statements, general ledgers, payroll tax returns, etc. until an acceptable offer has been made as this information is corroborating material, but without the profit and loss statements and tax returns how can you even make an offer? Know when to walk away.

For a realistic assessment of your practice, call Kurt Skarin with Lee Skarin and Associates.

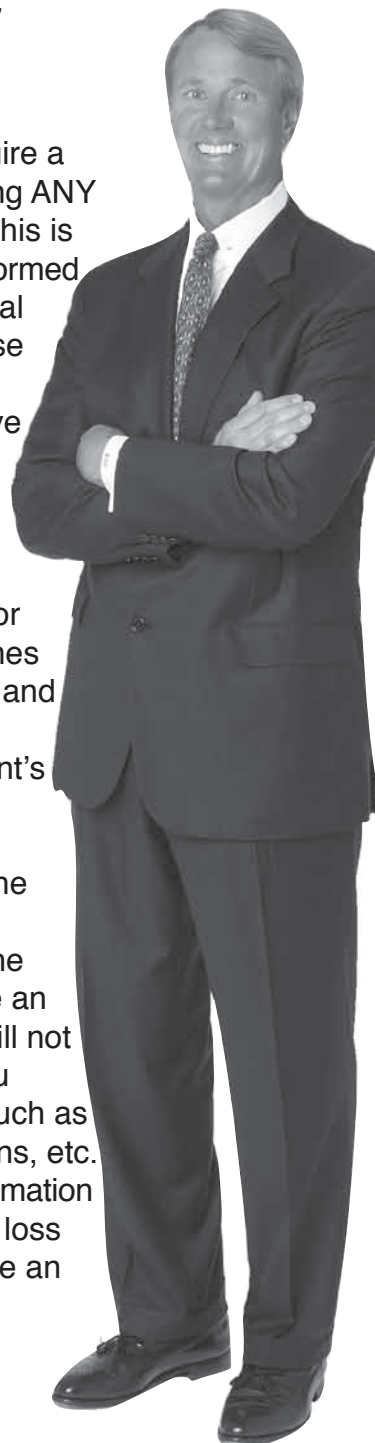

CA DRE #00863149

LEE SKARIN & ASSOCIATES INC.

Call for Free Consultation! 805-777-7707 or 800-SKARIN #1 (800) 752-7461

Place a FREE Reader Ad online at www.thedentaltrader.com

LCF Practice Sales & Financing

Free consultations for Buyers & Sellers
BUY PRACTICE • SELL PRACTICE • FINANCE PRACTICE

ATTENTION SELLERS!

We currently have
Pre-Approved
 Buyers for dental
 practices located in
**Orange County,
 Los Angeles,
 Riverside,
 San Fernando Valley,
 San Diego County
 and the Bay Area.**

Call to List
 Your Practice
 With Us Today!

Toll-Free:
1.800.550.9228

Upcoming Listings:

- Modesto
- North Hollywood

“Loc Pham is a true professional. He worked very hard to sell my practice, and I'm very happy I listed with his company, LCF Practice Sales. I would highly recommend Loc and his staff to my friends and colleagues.”

-Farzad Shaygan, DDS, MS

We Offer Up to 100% Practice Financing!

- Practice Sales
- Working Capital
- Refinance/Consolidate
- Equipment Leasing
- Real Estate Acquisitions
- and So Much More!

Dental Practice for Sale Los Angeles County, CA

Gardena - Busy Intersections

- Strip mall nearby anchor stores.
- High Traffic. Great Visibility.
- 4 Operatories, ~2100 sq.ft.

Long Beach - Busy retail center

- Perfect location for a Starter Practice. Major anchored stores.
- Affordable Rent. ~1,000 sq.ft.
- 3 Eq. Ops + 1 add't plumbed

Long Beach - Beautiful Office

- Over 20 years of Goodwill
- 5 Operatories, ~1,300 sq.ft.
- Mixed Income & Stable Pt Base

Los Angeles - Gross ~\$400K

- Highly Visible from busy streets.
- Affordable Rent! Cash/PPO
- 3 Eq. Ops plus 2 add't chairs.

Los Angeles - Gross ~\$356K

- Well Known Medical Building
- Close to Retail/Shopping Center
- 4 Operatories, ~1,397 sq.ft.

Panorama City - SOLD!

- Busy street. Good Visibility.
- 3 Operatories, ~970 sq.ft.

Santa Monica - Gross ~\$300K

- Seller Retiring. Highly Visible
- 4 Equipped Ops, ~1,397 sq.ft.

Valencia - Gross ~\$560K

- Real Estate & Practice for Sale
- State of the Art Practice
- Increasing Revenue, Cash/PPO
- 6 Operatories, ~2,200 sq.ft.

Dental Practice for Sale Fresno County, California

Coalinga - Freestanding Building

- Gross ~\$589K on 3-4 days/wk.
- Great Visibility. Busy Main Street
- Paperless office.
- 3 Eq. Ops, Approx. 1,200 sq.ft

Dental Practice for Sale San Diego County, CA

La Jolla - Gross ~\$350K

- Retail Center, digital office.
- Mostly PPO, 2 Equipped Ops.

Dental Practice for Sale Orange County, California

Fullerton - SOLD!

- Seller retiring, 20 yrs goodwill.
- In main street, strip mall.
- 2 Eq. Ops + 1 add't plumbed.

Laguna Hills - New Listing!

- Gross ~\$217K.
- Increasing Revenue. Cash/PPO.
- Beautiful, Modern Office.
- Busy Retail Shopping Center.
- 4 Eq. Ops, Approx. 1,750 sq.ft.

Mission Viejo - Gross ~\$1.2 Mil

- Large Shopping Center
- Mostly PPO/Stable Pt Base
- 7 Operatories, ~2,700 sq.ft.

Santa Ana - LOW RENT!

- Highly Visible Corner Office.
- Busy Street. High traffic
- 3 Eq. Ops, Approx. 1,100 sq.ft.

Santa Ana - Gross ~\$345K

- Main Street, Downtown
- Mostly Dential, ~2,392 sq.ft.
- 5 Eq Ops + 2 Add't Plumbed

Dental Practice for Sale San Bernardino County, CA

San Bernardino - Starter Practice

- Asking \$25K or Best Offer!
- 1063 North D Street
- San Bernardino, CA 92410

- Private parking in the back.
- 2-3 Equipped Ops / 4 Plumbed
- Low Rent! Approx. 1,163 sq.ft.
- No Patient Base.

Buy Two Practices Together Dental Practices for Sale in

Rialto & Rancho Cucamonga

- Practices Gross ~\$906K
- Both Dental Practices are in Large Retail Centers.
- Rialto: ~3,500 sq.ft. 8 Ops
- Rancho: ~2,100 sq.ft., 5 Ops.
- Don't Miss This Opportunity!

Dental Practice for Sale Stanislaus County, CA

Modesto - Gross ~\$830K

- GP located in strip mall.
- Cash/PPO, ~3,200 sq. ft.
- 7 Eq Ops + 1 Add'l plumbed

Dental Practice for Sale Northern California

Concord - Gross ~\$125K

- Practice & Real Estate Available
- Freestanding building
- Mostly Cash/PPO
- Good visibility. ~1,500 sq.ft.
- 2 Eq Ops, 2 Add'l Plumbed

Dublin - Gross ~\$785K

- Prime location. Shopping Center
- Mostly PPO/Cash Patients
- 5 Operatories, ~1,800 sq.ft.

Fremont - Gross ~\$485K

- Busy main streets, ~2,000 sf.
- 4 Eq. Ops + 3 add't plumbed.

Gilroy - Gross ~\$243K

- Large shopping center.
- 3 Eq. Ops + 2 add't plumbed.

Hayward - Gross ~\$438K

- Located in shopping center.
- Mostly Cash/PPO, ~1,800 sf
- 4 Eq Ops + 1 Add't Plumbed

Hayward - LOW RENT!

- Good Street Visibility
- Cash/PPO, ~1,000 sq.ft.
- 2 Eq Ops + 1 Add'l plumbed

King City - New Listing!

- Gross ~\$650K.
- Large retail shopping center.
- Over 10 Years of Goodwill
- Approx. 1,375 sq.ft.

Salinas - Gross ~\$243K

- Shopping center. Cash/PPO.
- 3 Eq. Ops + 2 add't plumbed.
- Very little competition around.

San Jose - Great Location

- Strip Mall. Busy Street.
- 3 Eq. Ops, Approx. 1,040 sq.ft.
- Close to Freeway 680

San Jose - Asking 15K!

- Or Best Offer!
- Starter Practice w/ Patient Base.
- Stand alone Building.
- 5 Eq. Ops, Approx. 2,000 sq.ft

For our complete
 listings, visit us at
LCFPracticeSales.com

or Call Today at
 (714) 550-7494
 (800) 550-9228

Call Loc Pham, Broker (714) 550-7494 for More Information!

Email: Practice@lcfpracticesales.com | Website: LCFPracticeSales.com

A Division of LCF Financial, Inc. BRE #01875780

Unhappy with your Health Insurance? Open Enrollment is here!

If you are unhappy with your current health plan, you have the option to change it, but only during Open Enrollment. November 1st is the first day to enroll to obtain health care for the 2016 year. Open Enrollment will end on January 31st, 2016. You only have this opportunity once per year! Also, if you are uninsured, this is your chance to enroll!

For a free online quote visit our website:

www.tdibroker.com/healthquotes

Questions? Email our health insurance expert!

ashley@tdibroker.com



"Thank you for helping us with getting the right coverage! So many choices!"

-Dr. Todd Brilliant and family



**THE DOCTORS
INSURANCE BROKER™**

AMY L. BORDEN, ESQ., APC "I saved over \$20,000. Ms. Borden reviewed my commercial lease agreement and was able to extend the lease term and secure a rent reduction which saved me over \$20,000 over the life of the lease." Dr. Giri Palani, President, Total Smile Care.
www.californiadentalattorney.com.

Dental office for sale Exceptional DDS.com Fully digital and paperless. 6 ops. Surgical recovery room. Whittier California. Only 120k! 949-510-0225.

MISSION VIEJO ORTHO PRACTICE FOR SALE – 3+ operatories in 1200 square feet in professional building for over 20 years – grosses over \$13,000/month on 2 short days/week – contracts receivable over \$65,000 - Thomas & Fees Practice Sales (714) 544-4341.

PRACTICE FOR SALE WEST LA, GP W 3EQ OPS 17 YEARS GDWL; SALE BY OWNER/RETIRING; GOOD LOCATION, CALL (310)636-9292.

Dental Assistant Needed in Wilmington, CA Email resumes to fshadaieedental@yahoo.com Thank You.

P.F.S DON'T OVERPAY FOR THAT PRACTICE! Call Sunwest Bank FIRST- 714-730-4412. Sunwest Bank... Where Sensibility And Flexibility Meet.

Associate needed Full-Time in the Central Coast multiple locations available. Possible partnership for the right candidate. Base pay plus production, new graduates welcome. Send resume to friendlysmilesdentalgroup@yahoo.com or fax to (805)928-6788.

SHASTA COUNTY, CA Grossing \$851K, Beautiful Office, Est 25 Yrs, 6 Ops - 100% Financing Available. Call ProMed 888-277-6633 [Ref#D238].

Northridge fully equipped dental office in shopping center great location no patients. 818 709-8645.

n-Office Equipment Repair 50% OFF FIRST HOUR Friendly. Prompt. Professional. Honest. Contact Us Today! 877-535-1733 / www.repairmakers.com.

Cecilia Chen, Esq is very knowledgeable in dental law, particularly when it comes to partnership buyouts and practice acquisition. – Richard Lindsay, DMD.

Looking for a Dentist Position willing to learn and help to grow your practice 786-651-8381 or jujikal@comcast.net.

Replacement upholstery kits for chairs and stools. Give us a call, we make it simple. Superior Upholstery Company 888-548-7282 superiorupholstery.com.

LOOKING TO BUY Dental Office from retiring dentist. Got a practice to sell in Orange County? email Garry: incognitoo@earthlink.net.

Practice Management Software Pricing at just \$499, unbelievable price for the single computer "workhorse" version. Must purchase before October 31st for offer. Must mention: DMAX15. Call 1 (800)397-6046.

Purchasing your new practice, call Bob Affleck @ Citi Practice Finance he will be your biggest advocate 949-939-4550.

www.dental-attorney.com

My Law Firm is Nothing Without You!



Levi Barlavi, Principal of the Pacific Health Law Group

Toll Free: (888) 995-5384

Legal Services *for* Dentists

- Practice Acquisitions/Sales
- Lease Reviews & Negotiations
- Professional Corps & Partnerships
- Employment Law Matters
- Space Sharing Agreements
- Dispute Resolution/Litigation

"I would like to recommend Levi Barlavi for his excellent work, customer service and reasonable price point. Over 6 months ago, Levi provided me with the BEST legal help as I purchased my very first dental practice. He was instrumental in advising me about setting up my corporation and also reviewing the most important legal documents relating to my practice. I would not hesitate to work with Levi in the future and I have already recommended him to all my friends who are considering starting a corporation or buying a practice."

-Melanie Marshall, DDS

"Dr. Marshall, it was a pleasure to represent you in your transaction. Thank you for your trust in my practice. My law firm is nothing without clients like you. I never forget this point! I look forward to your continued success."

-Levi Barlavi, Esq.

As an attorney specializing in meeting the legal needs of dentists throughout California, I have a simple goal: **to add value to your practice.** I accomplish this by being accessible, thorough and placing my client's needs first. I am committed to client service because I know it is what you want, and what will secure your return business and referrals. That is the greatest compliment! If you want to like your attorney in addition to receiving thorough legal work please call me today for a free consultation. Let me earn your trust.



Los Angeles | San Diego
www.dental-attorney.com

Protecting Your Investment, So You Can Grow Your Practice.

DENTAL PRACTICE FOR SALE DIAMOND BAR: Shopping Center. Super Look 4 Ops. Retiree. Big upside. Call Broker - Practice Sales & Appraisals (818) 999-9595.

Need GP 4 PEDO, near the Bakersfield area, PT. Guaranteed Base & % of Production. Please send CV to paulinanr@sbcglobal.net.

Removable Laboratory For Rent Fully equipped removable lab, in Huntington Park for lease. Low rent. Call 310-963-7675 or email: jakesaedi@gmail.com.

FACT In dentistry your **HEALTH** is your **WEALTH...Is your income & family protected?!?! Call for a FREE Disability Insurance Appraisal 855-346-9729 di4dds.com.**

OCEANSIDE Just Listed! Equipment and Leasehold Improvements. 3 ADEC Ops, Intraoral Cams, Panoramic, Digital and more. VERY Low Price. SDPS: 760-599-7828.

Looking for a par-time Dentist to work in Santa Ana. New Grads welcome, flexible hours, please call us at 714-550-0503.

LA MESA Looking for dentist to invest in established practice, become a partner for more growth. For details - stabmd@gmail.com.

PRACTICE FOR SALE EL CENTRO GP + BDLG w/ 60 yrs gdwill NET of \$87K California Practice Sales, Inc. Phone: 714-639-2775.

Board certified Oral Surgeon, 5 years of experience available to come to your office. Flexible schedule/weekends. Email me laoralsurgeon@gmail.com.

Looking for GP for two Saturdays a month in West Covina. Spanish speaking prefer. Salary + call Josie at 626 330-6655.

40 ENDO OBTURATORS WITH NEW OVEN! \$195!FREE SHIPPING! Email for pictures. Will deliver and demo in LA County. (310) 699-3441 profitablegps@hotmail.com.

DA/RDA needed in Jurupa Valley/Riverside area. Send resume to whangdmd@yahoo.com or fax 9516814669.

Mineralized Cortical bone 250-1000um Lowest pricing anywhere great for extractions \$22.00 per .25cc www.denatalprodx.com.

General Santa Monica office needs Dental Assistant one year/ more experience. Must have x-ray license, great personality, high energy. smdentaljobs@gmail.com.

Dentist P/T needed in Burbank. Please email CVT to dentist-sassociates@gmail.com.

OXNARD (4) op comput. G.P. for sale. Located in a prof. bldg. with ample free parking. Dentrix s/w & digital x-rays. 2014 Gross Collect \$264K+ on a (3) day week. Cash/Ins/PPO/HMO/Denti-Cal pts. Seller refers diff. Endo & O.S., all Perio & Ortho. and does no advertising. Seller taking non profit position. D&M Practice Sales 818.591.1401.

Looking for periodontist to do implant surgery and perio surgery in a GP office located in San Gabriel Valley. Please email vtchen@yahoo.com.



FACTOID: 30% of all used dental equipment placed for sale on The Dental Trader Ad Board sells before the ads ever appear in print. New items appear daily.

dentaltrader.com

Ready to build your dream practice? Allow Live Oak Bank to finance your construction project with up to 100% financing. 877.890.5867 www.liveoakbank.com/healthcare.

Busy and productive dental practice in El Centro CA is looking for an experience General Practitioner. make up to \$1000+ a day. Must be able to do all facets of dentistry from basic restorations, extractions to molar root canals. Minimum of 3 years experience as a GP, must have malpractice insurance and current dental license. (760) 336-2600.

FREE PHONE CONSULTATION AND GUIDANCE FROM THE LEADING DENTAL ATTORNEYS IN THE COUNTRY? What do you have to lose? CALL TODAY 800-499-1474 WOOD & DELGADO www.dentalattorneys.com.

For Sale Escondido 3-OPs, stand-alone building, 20-30 new patients/month! great low-risk office for newer dentist! digital, EasyDental, Tranquil! maw416@nyu.edu.

Litigation is the new retirement plan...if you find yourself placed in a defensive position, call Kerendian & Associates. We'll protect you. Call Kerendian & Associates 888-299-7848.

General Dentist needed PT Los Angeles/OC locations must be friendly and hard working great compensation. email resume to bestdentalla@gmail.com.

Create the Office of your Dreams with All County Construction. Enhanced to your style, designed to your budget. 714-240-7179.

Prosthodontist immediate-opening, 5-10-yr exp, great diagnosis skills/producing. 1. experience in Cerec; 2. implant restoration; 3. speaking Chinese email:dds898@gmail.com.

If delivering a better dental experience for your patients is your goal, upgrading or expanding your practice is one of the best investments you can make. Call Wells Fargo Practice Finance at 1-888-937-2321 or visit us at wells Fargo.com/dentaltrader.

Spacious, beautiful state-of-the-art specialty office in Beverly Hills offering sublease for an orthodontist or endodontist. Cone-beam CT. Please email: beverlyhillsoralsurgeon@gmail.com.

CONTRA COSTA COUNTY, CA: PART-TIME GENERAL DENTAL PRACTICE, 900 SQ FT, 3 OPS. 100% FINANCING AVAILABLE. CALL PROMED 888-277-6633 [Ref#D810].

MADE IN USA / 10 YEAR WARRANTY

\$5495 or **\$99**_{PMOAC} Installed*
Including Dentist Stool



America Operator



*Our
Best
Value*

\$5995 or **\$99**_{PMOAC} Installed*
Including Dentist Stool



Universal Operator



*RADIUS
SYSTEM
Right
Left Use*

Normal Installation within 1.5 hours of Factory*

Upgrade your Operator - New Delivery System & Dental Light.

\$2595
for Both

MADE
IN THE USA

Will install on any Dental Chair *
(Mounting Bracket may be required)



Super Flow 10 Dry Vacuum

Super Flow 10 Dry Vacuum \$4995
Cash Rebate From DHP \$1000
Metro. Water District Rebate \$500

****Net Cost \$3495**

Dansereau Dental 1581 Commerce St. Corona CA 92880
WWW.DHPDENTAL.COM / (800) 423 - 5657 / MADE IN USA

FOR SALE Edge-Ease Large. Total 5 boxes (300/box). 3 are partially used. All for \$95. Email for pictures. gaw1177@gmail.com.

FRIENDLY SHERMAN OAKS OFFICE LOOKING TO SUBLEASE PART-TIME TO A DENTIST WITH THEIR OWN PATIENTS. PLEASE CALL 818-995-8484.

A 33-month study of 43 patients with 121 recession sites treated using the Pinhole Surgical Technique was published in Oct., 2012, by The International Journal of Periodontics and Restorative Dentistry to international acclaim. Visit pinholesurgicaltechnique.com.

HU-FRIEDY INSTRUMENTS Gracey (11/12) (13/14), Scaler (H5/U15), Explorer, Columbia, Barnhart, Morse. Like New, Make Offer. 855-772-7645 janetm@hygiacare.com.

CAVITRON ULTRASONIC SCALER (Select SPS 30k) (#81302) & Reservoir Pump (#90146) Like New, Cost \$2,758, Make Offer 855-772-7645 or janetm@hygiacare.com.

HUNTINGTON BEACH General Practice. 5 Ops, est. 28 years, Professional building, Digital, Pano, Laser, 12 days of Hygiene/week. HSPPT-Kerri McCullough 949-566-3056-#CA263.

Looking for Associate Dentist National City. Base plus incentive, possibility to purchase practice in the future. Experience preferred. Call 619-477-2787.

INTRAORAL CAMERA (2)-Magenta MD960U, Like New, Cost \$249 each, Make Offer 855-772-7645 or janetm@hygiacare.com.

HUNTINGTON BEACH LOCATION Excellent Opportunity for a GP or Spec 3 treatment rooms, 2 consultation rooms, 1 recovery room, & plumbed for 2 additional treatment rooms. Nice Build-out! Greg Beamer, Dental Broker 909-542-4891.

Well-established state of the art orthodontic office in West Los Angeles seeking an experienced Pedodontist who is highly motivated and takes pride in providing high quality care. Please submit your CV to: westlaortho@gmail.com.

DENTAL PRACTICE FOR SALE IN SANTA ANA Starter Practice. Strip Mall. Highly Visible Corner Office. High traffic. 3 ops. 1,100 sq.ft. Low Rent! Loc Pham, Broker at LCF Financial, Inc. BRE #01875780, (714) 550-7494 or practice@lcfinc.com | LCFPracticeSales.com.

ULTRASONIC (PATTERSON PA-4) Like New, Cost \$450, Make Offer. 855-772-7645 or janetm@hygiacare.com.

Vista 6 Ops. 1,500 Sq ft. 26 yrs. of Goodwill. Office Condo for sale also. Seller retiring. Located in Professional bldg. Ken Rubin Practice Sales (619) 299-6161.

Experienced proficient periodontist is available to perform all aspects of periodontal surgery, regeneration, extractions and bone grafting in your office. May sign up with dental plans. Please email at mmperio@aol.com.

Dental Office manager needed. Spanish speaking required. We are willing to train. Call me at 786-301-6708.

PRACTICE FOR SALE SANTA ANA GP in busy strip mall; NET \$184K California Practice Sales, Inc. Phone: 714-639-2775.

Want to build a thriving practice? Call Wells Fargo Practice Finance for a complimentary consultation today, at 1-888-937-2321.

ASEPTICO Compricart ADU-20B Delivery Unit with Fiber Optic Scaler. Like New, Cost \$2,690 Make Offer. 855-772-7645 janetm@hygiacare.com.

Complete Dental Office Fully Equipped with Made in USA Dental Equipment for under \$25,000. Call (800) 423 - 5657 for more details.

Santa Monica GP looking for associate Dentist for Fridays & Saturdays. Must have DEA license, liability insurance, US trained. smtoothdr@gmail.com.

Look for your free wall-hanging color calendar soon...compliments of The Dental Trader Advertisers!

Dental Office Staff Hawthorne practice looking for:
 * Tracer/Biller w/ 3 years experience * Treatment Coordinator - w/ 3 years experience, Saturdays a must, fluent Spanish speaker preferred. We offer generous insurance benefits and vacation pay. Staff members eligible for bonuses. Privately owned practice with 140+ employees. We are a family of co-workers with long term job security. Email Hawthornedentist100@yahoo.com or Fax 310-679-6698.

PT Dental Assistant for front/back needed. Experience preferred but not required. please email cv to dentistsassociates@gmail.com.

Memory foam ultraleather, massage systems. Are you relaxed yet? Superior Upholstery Company 888-548-7282 superiorupholstery.com.

PT General Dentist needed in Burbank please email cv to dentistsassociates@gmail.com.

Pediatric clinic in Costa Mesa is seeking an Office Manager. Must have 1 year experience. Email resume to dentalcareers@shareourselves.org.

Plumbed ready with cabinets one or two operatories for long term or month to month Eagle Rock.(818)749-1841 hamletabnous@sbcglobal.net.

Purchasing your first practice? Bob Affleck at Citi Practice Finance he will guide you through the process 949-939-4550.

Taylor Liao, Manager of Kings Two Dental Supply (City of Industry, CA)-What can I say about him? He's the lawyer we go to when we need a lawyer. Dr. Chester Jeng of Law Offices of Jeng and Associates is very personable and knowledgeable in dentistry and law. He's definitely a straight shooter, he tells you what you need to know and also what you probably do not want to hear. He's the one we go to if we need a lawyer. Call Jeng & Associates 714-858-0536.

PELTON & CRANE DENTAL LIGHT, ceiling mount, excellent condition, \$150.00. Call (818)325-7868 for photos/further info. Must pick-up (SFV).

Dentist needed for Long Beach private office. Must be a Denti-Cal Provider. Email resume to nationaldental@verizon.net.

STERILIZER REPAIR 15% OFF FREE Estimates. Fast Turnaround. Loaners Available. Contact Us Today! 877-535-1733 / www.repairmakers.com.

If you have cell service...

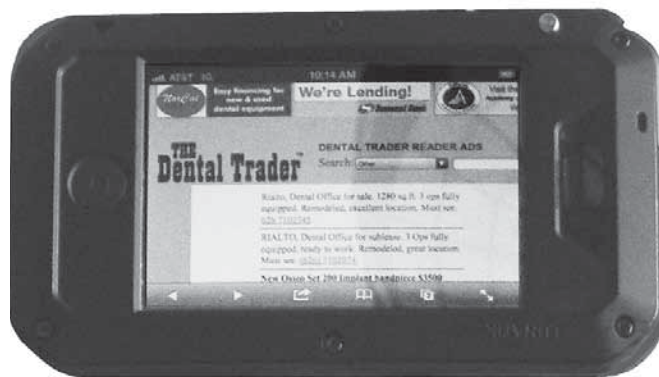

...you have
The Dental Trader!
 As mobile as you are.
dentaltrader.com

A Different Kind of Dental Attorney

I know dentistry's unique legal & financial challenges

Services

Incorporation
Estate Planning
Buy/Sell Agreements
Lease Reviews
Space Sharing
Agreements
Workers' Compensation
Practice Sales

**Call us
for other services!**

Member

CA State Bar
NC State Bar
US Federal Courts
US Federal Tax Courts
Calif. Dental Licensure

Testimonials:

Jeng and Associates have represented me in buying 3 offices and multiple lease reviews and negotiations. Their professionalism is unbeatable and Dr Jeng is always available to answer my questions by phone or email.

Dr. L. Kong, Daly City, Ca

I highly recommend Dr Jeng as a dental attorney. His experience as a dentist combined with his legal experience gave me the confidence to enter into a share office arrangement. He was always available to answer my calls and addressed all my concerns and questions.

Dr. P Tran, Burbank, Ca

Dr. Chester Jeng represented me in my last two dental office purchases. Very professional and helpful. He is my go to lawyer for my legal needs.

Dr. K Chou, Hacienda Heights, Ca



Law Offices of Jeng and Associates Chester Jeng, DDS, JD, LL.M

Cell: (909) 450-7158 • (714) 858-0536
Jenglaw.com • Jenglaw@yahoo.com

1440 North Harbor Blvd., Suite 900, Fullerton, Ca. 92835

*Disclaimer: Monthly tip is not legal advice and in no way attorney-client privilege has been created. Consult a CPA or attorney if you need tax or legal advice.

WE'RE LIKE DOCTORS FOR YOUR DENTAL EQUIPMENT — KINDA, SORTA

REPAIRMAKERS

DENTAL EQUIPMENT REPAIR PROS

Schedule Service 877.535.1733
www.repairmakers.com

"We love working with RepairMakers, very professional team with great customer service. They service all three of our offices, from equipment service to handpiece repairs — we highly recommend them."
—Garden Dental Group

"I have been in Dentistry for over 36 years and I've experienced many repair companies. RepairMakers, by far, have provided the best, most reliable service in my 36 years of practice. I recommend RepairMakers to anyone needing equipment repair and support."
—Scott King DDS

RECEIVE A \$75* CREDIT WITH YOUR FIRST PAID REPAIR ORDER.

*CANT COMBINE OFFERS. CREDIT GOOD ON FUTURE SERVICES ONLY.

Legal Tip: Buyers Who completes and pays for retreatments? For how long? Attorney Robert W. Olson, Jr., 805.963.1120, www.transdental.com.

Associate Dentist Pediatric Dental Specialty office seeking child friendly General Dentist Conscious Sedation Permit Required Chatsworth office pediatricdentist18@gmail.com fax 8187730911.

Cecilia Chen, Esq has a strong background in real estate and practice purchase and sales. Let us assist you in your next practice transition.

ANAHEIM PRACTICE AND BUILDINGS FOR SALE — Dr retiring after 37 years in this location — 3 operatories — grosses over \$400,000 on 4 easy days/week with low overhead of 55% - 3 separate buildings on same lot — one is 700 sq ft, one is 900 sq ft and are both unoccupied and the 3rd building has two dental offices of 1070 sq ft each - Thomas & Fees Practice Sales (714) 544-4341.

Looking for dentist exp in Pedito/ avg \$800-1200/day. Dential provider a must!! Los Angeles Area Contact at dental4kidz@yahoo.com.

Our latest SoCal course series includes 2 Lectures + a Hands-on Direct Composite Veneers Course, 21 CE units, all on Sundays, for only \$449! Visit www.xcelseminars.com for info.

ORANGE COUNTY, CA GENERAL DENTAL PRACTICE, 3 OPS, 4200 CHARTS, FULLY EQUIPPED. 100% PRACTICE FINANCING AVAILABLE. CALL PROMED 888-277-6633 [Ref#D809].

ORANGE General Dentistry. 4 Ops, 3 Equipped near Old Town and Freeway. Est. 56+years, digital. 2014 GR \$429K. HSPPT-Thinh Tran 949-533-8308-#CA256.

Cerec 4.3 Bluecam/milling unit with 400 mills for sale, over \$3000 in accessory and oven. Total \$45000. Email nbp8011@gmail.com.

BEAUTIFUL ALL DIGITAL, 3 OP PRACTICE AVAILABLE FOR SUBLEASE/SALE IN THE HEART OF WEST LA. PERFECT STARTER PRACTICE FOR NEW GRADS OR SPECIALTY. TERMS FLEXIBLE. CONTACT, KONVISERDDS@YAHOO.COM.

P.F.S BUYING A DENTAL PRACTICE? Call Sunwest Bank for all your lending needs - 714-730-4412.

ENDODONTIST IN YOUR OFFICE Experienced Endodontist with supplies+qualified staff. Bilingual English/Spanish To Cover OC, LA, RS County
Endodontist.inhouse@hotmail.com.

Sterilization pouches 3.5 x 5.25 case of 2000 \$72.98 or 3.5 x 9 for \$74.77, www.dentalprodx.com.

Burbank Office needs PT Dental Assistant CPR XRAY LIC 2YRS Exp -Front&Back Email CVT to dentistsassociates@gmail.com.

Prevent associate employment issues. A strong associate contract will establish the guidelines for a smooth working relationship. Free Consultation. (310) 776-5384
www.dental-attorney.com.

REAL ESTATE | ACQUISITION | EXPANSION | NEW CONSTRUCTION | REFINANCE | START UP

WE'VE GOT YOUR BACK, FROM BREAKING GROUND TO FINAL BRICK.



With financing designed to preserve your cash, you can get started on your new office today.

Let your Dental focused lending team and dedicated construction team carry the weight. Contact one of our lenders to get started.



JP Blevins
General Manager
910.796.1674



Mike Stanton
Loan Officer
404.995.2003



Mike Montgomery
Loan Officer
910.798.1215



Lindsay Harkey
Loan Officer
910.550.2277



LIVE OAK BANK
liveoakbank.com

Visit liveoakbank.com/dental-trader for your free guide to "Managing Your Financial Profile"

©2015 Live Oak Banking Company. All rights reserved. Member FDIC

Award Winning Digital Sensors. Try our sensors before you buy with no obligation. Includes size 2 and size 1 sensors with imaging software. Call 1(800)397-6046.

DENTIST needed for office in La Puente/West Covina. Minimum 2 years experience. Reply resume to vzar@hotmail.com.

HUNTINGTON BEACH LOCATION MOTIVATED SELLER 1,800 sq. ft. suite w/ a nice build-out on a main street w/ great exposure. A must see & priced to sell! Greg Beamer, Dental Broker 909-542-4891.

PANO FOR SALE W/CEPH 1989 SEIMANS ORTHOPANTOMOGRAPH MODEL OP 10S \$1000.00 OBO. CALL 714-335-1161 OR 562-421-8896.

Over 200 Dental Practice Transitions Completed in 2014. CALL IS TODAY FOR A FREE TELEPHONE CONSULTATION! 800-499-1474. WOOD & DELGADO www.dentalattorneys.com.

Orthodontist needed for brand new start up practice in Fountain Valley with the potential to buy the practice. email Inguy-ends@aol.com.

PRACTICE FOR SALE Carlsbad. Estab. FFS GP. 5 Ops in 1500 sq.ft. Digital. SDPS: 760-599-7828 SOLD!!

General-Dental 2850SF Office in-Pasadena for sharing space, and lease with any Dental specialty or MEDICAL practice. Call 714-400-7734 EMAIL sohrabyazdani@sbcglobal.net.

Have a commercial lease? Is your office lease as thick as a novel? Need to know what's hidden inside that? Call Kerendian & Associates 888-299-7848.

Children's Dentist Needed We are proud to have built a thriving, quality oriented private dental practice in the South Bay. Practice is at a single location owned by a dentist, not a chain. Looking for full time associate in Pediatric Dentistry. Saturday hours a must and need Dent-cal provider. Excellent compensation, minimum two years experience. Email Hawthornedentist100@yahoo.com or fax (310)679-6698.

Looking to associate GP and buy out in few months. At least 4 chair office, 500k+ gross only. 872.222.8722.

It was a great pleasure to work with All County Construction a very professional company that listens to me. Dr. F Tacharina. 714-240-7179.

Looking for a traveling ENDO, ORTHO and OS. once a month grow to more days. Email onlytops@gmail.com with salary req.

X-RAY UNIT \$250. Wall mounted remote button purchased new 15 years works well very good condition First \$250 CALL 909-838-5702.

PRACTICE FOR SALE HUNTINGTON BEACH GP w/ 42 yrs gdwll / 4 eq ops California Practice Sales, Inc. Phone: 714-639-2775.

Receptionist needed in private dental office in South OC. 3 days/week. Email resume to maihrmanager@gmail.com.

Gorgeous practice in Tarzana for sale. 3 ops, doctor office, panoramic, New Ac/heater, great lease, low overhead, asking 350k robert21b@yahoo.com.

HOW REFRESHING



"Amy Borden assisted me in the sale of my California dental practice and purchase of my new Utah practice. Amy listened to me and carried out my wishes. Both transactions went smoothly and were completed on time. Amy is a competent, accessible and affordable attorney. Give her a call! You'll quickly see how refreshingly different she is."

Paul A. Peterson, D.D.S.

Flat Rate Services include:

- Buy-Sell Agreements (practice acquisition)
- Associateships/Partnerships
- Formation of Corporation
- Lease agreement review/negotiation
- Contract drafting/review
- Space sharing agreements

Call for a complimentary consultation

Amy L. Borden, Esq., A.P.C.

888-416-1321

californiadentalattorney.com

amy@californiadentalattorney.com

Dedicated to serving dental professionals

DentiMax

Sensor Special

Prices are falling like the leaves!

Ends October 31, 2015



\$1,000 Discount Off Each Sensor



- FREE 5-Year Extended Warranty
- FREE Imaging Software
- FREE Year of Imaging Software Support
- FREE Installation, Set-Up and Training

Call (800) 397-6046

Buy it! Sell it!! Trade it!!!

"I have patients flying from Europe to get this procedure!" The all new Pinhole Surgical Technique eliminates the need for grafts, incisions, sutures, patient discomfort and heals overnight! Visit pinholesurgicaltechnique.com for stunning development!

Associate Dentist Needed Menifee/Lake Elsinore - Busy office, great staff. Can make \$550 to \$800 per day. Email CV drhortonz@hotmail.com.

Searching for the right bank? Look no further than Live Oak Bank. Our lenders understand your business and specific financing needs. 877.890.5867 www.liveoakbank.com/healthcare.

TOP QUALITY ORAL SURGERY IN YOUR OFFICE (OC/LA areas). Stop referring out. Friendly, experienced OMFS performing surgical procedures in your office. Wisdom teeth, implants, sinus lifts/grafting, All-on-4/6, full mouth rehabilitation, Basic Perio also. IV sedation. Will bring assistant, implants, all instruments/equipment. Great with patients. Please email with any questions. johnknour@gmail.com (949)463-6637.

Every year California dentists place thousands of ads in The Dental Trader...more than any other regional or national dental publication in the nation! Join them...get results! The ads are free. Visit dentaltrader.com.

Office Manager/Treatment Coordinator Needed. Bilingual, know HMO, pay well, Monterey Park. (F)626-574-8948. (C)626-622-2380. Dr. Chen.

I've had Monica as my accountant for over 15 years. I really like her. I actively refer to her and the reasons are she's a strategic accountant. James E. Bollinger, D.D.S. (See Rebella Accountancy ad in Dental Directory)

Oxnard dental Practice for sale. 30000 traffic count, 18 NP Walkins. 5 operator practice, 3 plumbed. 55000\$ Hispanic Area. Gassatou@yahoo.com.

Dentist needed for Fast Pace office Glendale area on San Fernando RD please fax CV for working interview 323-222-8885.

DENTAL PRACTICE FOR SALE IN KING CITY Established Practice. Large retail shopping center. Mostly PPO. Lots of Goodwill. Loc Pham, Broker at LCF Financial, Inc. BRE #01875780, (714) 550-7494 or practice@lcfinc.com | LCFPracticeSales.com.

Anaheim private office looking for general dentist (2 yrs exp min) for PT. Pls send CV to tdds27@yahoo.com.

Registered Dental Assistants with Clinicas del Camino Real in Ventura County. Bilingual in English/Spanish required. Email resume careers@clincas.org.

Dental Assistant needed in LA,90066. Small private office. PT to FT. Must be punctual & professional Email resume: DDS90066@gmail.com.

ENDODONTIST needed. We are a General Dental Practice with a warm friendly atmosphere. Pls call (310)625-3840.

DENTAL PRACTICE FOR SALE ENCINITAS: Shopping Center. Beautiful Facility. Call Broker - Practice Sales & Appraisals (818) 999-9595.

Dentist needed 3 days per week 2 yr min exp must be medical rendering provider fax resume to rivdental@hotmail.com.

Legal Tip: Buyers Are you getting an EDD Release from the Seller? Attorney Robert W. Olson, Jr., 805.963.1120, www.transdental.com.

Registered Dental Assistant...Flexible and can work evenings/Saturdays...Knowledge of insurances and treatment planning, email resume to: belladental.elmonte@gmail.com.

Ortho Assistant needed 2 days a month pomona office. RDA preferred. Please email resume to saharadental@yahoo.com.

GP-DDS PT needed in Hemet 2-5yrs of exp preferred. Resume to fax(909)623-9915 or saharadental@yahoo.com attn. Judy

INLAND EMPIRE General Practice, 7 Ops. Dentrax, Digital. 30+years goodwill. HSPPT-Kerri McCullough 949-566-3056-#CA283.

Temecula Dental Practice Leaseholds. 1350 sf, 3 chairs, digital pano, \$1950/mo rent in strip mall. Asking \$79k OBO. 951-595-7764.

DENTAL X-RAY FILM. MINI - MAX. BRAND 50. BOX. \$20. each for sale 408-981-5069 Davidnader777@yahoo.com.

Cecilia Chen, Esq can help you ensure that your practice and family are protected through proper estate planning. Call us for a complimentary consult.

Don't let worn upholstery be your patient's first impression! Superior Upholstery Company 888-548-7282 superiorupholstery.com.

National City Practice for Sale Turn-key opportunity. Reasonably priced to sell, 4 ops, great base of returning clients. Call 619-477-2787.

Endodontic Practice North County Inland. Very nice State-of-the-Art practice. Phenomenal growth potential. 3 Ops. Must see to appreciate. Oppty to buy building also. Bargain Price for quick sale. Ken Rubin Practice Sales (619) 299-6161.

ADD \$250,000 TO YOUR YEARLY PRODUCTION! Request Our Free Production Building Guide Specifically Formulated For Practice Owners and Associates. profitableGPs@hotmail.com Tel: (310) 699-3441.

Looking for a general dentist who does endo. The office is located in Claremont please call ANDREW at 909 964 8167.

Need a Blast from the Past? Find anything printed in an old edition instantly using the search engine on our Dental Trader Archives page at <http://thedentaltrader.com/archive.htm>.

Want to fulfill your CE requirements, do a cool hands-on course and attend 2 additional lectures and get 21 CA CEs for one low price, all on Sundays, at one convenient OC location for only \$449? Go to www.xcelseminars.com to see our Southern California course series and register!

Prosthodontist wanted Beverly Hills multi-specialty office. Days and terms negotiable. Please email CV to dentalimplants90210@aol.com.

SOUTH RIVERSIDE COUNTY Growing area, affordable homes, family atmosphere, High End Practice w/6 eq. ops. & 1 plumbed not eq. op. located in a modern suite. 80% Insurance & 20% Cash. Greg Beamer, Dental Broker 909-542-4891.

You will not find lower prices!

Take advantage of this offer now! (Expires 10/31/15)

Allografts

Bone Particulate 250-1000um

Mineralized Cortical

.25cc	\$22.00
.50cc	\$45.00
1.0cc	\$61.00
2.0cc	\$97.00
5.0cc	\$175.00

Mineralized Cortical Cancellous

.25cc	\$32.00
.50cc	\$50.00
1.0cc	\$61.00
2.0cc	\$97.00
5.0cc	\$175.00

Mineralized Cancellous

.25cc	\$52.00
.50cc	\$67.00
1.0cc	\$99.00

Deminerlized Cortical

.25cc	\$33.00
.50cc	\$51.00
1.0cc	\$68.00
2.0cc	\$99.00
5.0cc	\$200.00

Deminerlized Cortical Cancellous

.25cc	\$39.00
.50cc	\$51.00
1.0cc	\$75.00
2.0cc	\$120.00
5.0cc	\$210.00

Pericardium's

15 x 20mm	\$88.00
20 x 30mm	\$99.00
30 x 40mm	\$140.00

DBM Putty Syringe (100% bone)

.70cc	was \$95.00 now	\$85.00
1.0cc	was \$150.00 now	\$125.00
2.5cc		\$280.00
5.0cc		\$650.00

DBM Crunch Syringe(100% Bone)

1.0cc	was \$150.00 now	\$135.00
2.5cc		\$280.00
5.0cc		\$650.00

TranZGraft Acellular Dermis

Compare to Alloderm

10 x 10mm	\$57.00
10 x 20mm	\$110.00
10 x 40mm	\$189.00
20 x 20mm	\$189.00
20 x 40mm	\$300.00

Same Day Shipping

Overnight Available

\$9.95 Flat rate Ground.

Xenografts

Bovine

Helimend Collagen Membrane

15 x 20mm	\$66.00
20 x 30mm	\$81.00
30 x 40mm	\$133.00

Resorbs in 8 weeks

Helimend Advanced Collagen Membrane

15 x 20mm	\$77.00
20 x 30mm	\$92.00
30 x 40mm	\$136.00

Resorbs in 18 weeks

HeliPlug 3/8 x 3/4 10/bx	\$94.00
HeliCote 3/4 x 1.5 10/bx	\$110.54

BUY 3 GET 1 FREE ON ALL MILTEX HELI PRODUCTS

THRU September! Free product ships with order!

RTM Collagen Membranes

Cytoplast RTM Collagen Membranes

15 x 20mm	2/bx	\$180.00
20 x 30mm	2/bx	\$224.25
30 x 40mm	2/bx	\$321.75

Buy 5 Get 1 FREE on all Cytoplast RTM's in September

MatrixOSS Porcine Bone Particulate

Porcine Bone Particulate 250-1000um

.50cc	\$80.00
1.0cc	\$125.00
2.0cc	\$215.00

Porcine Bone Particulate 1000-2000um

1.0cc	\$125.00
2.0cc	\$215.00

OTHER Wound Dressing Products

Collatene Microfibrillar Wound Dressing (for blood Coagulation)

.1g 15/bx	\$165.00
-----------	----------

S Tape Collaform Tape 25cm x 7mcm 10/bx \$267.00

MatrixDerm Cap Regenerative

Dental Membrane Cap

12 x 16mm	\$97.52
-----------	---------

BUY 5 Get 1 FREE ON All COLLAGEN MATRIX PRODUCTS (matrixmem/matrixderm/collatene/S-Tape/Porcine Bone) Till the end of September.

Synthetics

Benacel

Benacel Oxidized Regenerative

PLUGS

5mm x 7mm	8 per pack	\$32.55
-----------	------------	---------

6mm x 8mm	8 per pack	\$37.80
-----------	------------	---------

DENTAL DRESSINGS

15mm x 15mm	8 per pack	\$44.10
-------------	------------	---------

SynOss Synthetic Bone Granules

.50cc	\$51.00
1.0cc	\$62.00
2.0cc	\$120.00

SynOss Putty

.50cc	\$117.10
-------	----------

BUY 5 SynOss and Get 1 FREE

CYTOFLEX Compare to Cytoplast

Smooth Tef-Guard ePTFE Membrane

12mm x 24mm	1/bx	\$35.70
-------------	------	---------

25mm x 30mm	1/bx	\$45.15
-------------	------	---------

Textured Tef-Guard ePTFE Membrane

12mm x 24mm	1/bx	\$45.15
-------------	------	---------

25mm x 30mm	1/bx	\$55.65
-------------	------	---------

CytoFlex Mesh Titanium

12mm x 25mm x 0.1mm	1/pk	\$39.50
---------------------	------	---------

25mm x 30mm x 0.1mm	1/pk	\$46.37
---------------------	------	---------

30mm x 40mm x 0.1mm	1/pk	\$80.00
---------------------	------	---------

CytoFlex Resorb

12mm x 24mm	1/bx	\$75.60
-------------	------	---------

20mm x 25mm	2/bx	\$140.70
-------------	------	----------

30mm x 40mm	2/bx	\$210.60
-------------	------	----------

Algisorb Natural Alternative

0.5ml Vial	\$80.00
------------	---------

MISC

Dentogen Calcium Sulfate Hemihydrate

2 gram kit w/fast set	\$84.00
-----------------------	---------

R.T.R Syringe Tricalcium Phosphate	
.80 cc syringe	\$94.00

ACT Cell Dental Dressing Oxidized Cellulose

2 x 2 20/pack	\$115.00
---------------	----------

NanoGen Calcium Sulfate

2 gram Kit	\$128.00
------------	----------

1-888-392-3528

894 Germantown Parkway Suite 2
Cordova, TN 38018

DentaProdX.com
Toll-free: 888.392.3528 Email: info@DentaProdX.com

Buy it! Sell it! Trade it!!!

Peri-pro works great = \$950.00 w/ accessories View boxes (2) = 100.00. #(949)661-6255 ask for Roberta.

PRACTICE FOR SALE LOS ANGELES GP/Perio/Implant Beautiful office w/5 eq ops California Practice Sales, Inc. Phone: 714-639-2775.

Established Family and Cosmetic Dental Practice in Murrieta seeks experienced RDA to join our team. Fax 951-677-4564.

National City Practice for Sale- Turn-key opportunity. Reasonably priced to sell, 4 ops, great base of returning clients. Call 951-491-4058.

dental practice to share in great location in van nuys. Great for any specialty.call 8187859944.

Endo needed in PPO private office in Huntington Beach. 1 day/month. Needs own specialty equipment/instruments. Email: maihrmanager@gmail.com.

Is it time to consolidate your loans? Let's talk about how we can work together to simplify your finances. Call Wells Fargo Practice Finance at 1-888-937-2321.

front desk dental office experience only in billing insurance, and benefit, bilingual spanish ontario ca: ontariofamilydentistry@gmail.com.

Dental office 4 sale 2 op-rooms, X-Ray room in Hollywood, CA, rent \$1000, Price \$42,000. Call 818-432-3218 Ashot.

Staff exam gowns for \$26.17 per case of 50 polypropylene elastic wrist yellow or blue. www.dentalprodx.com.

DENTIST WANTED Currently looking for a General Dentist Associate with Vietnamese bilingual preferred. Minimum 5 years experience. We expect comprehensive exam, diagnosis and counseling to patients in professional manner. Opening job on Mon, Fri and Sat in Westminster, California. Please fax resume to (714) 895-7277 or call (714) 809-8088 and ask for Mr. Kim.

P/T Dentist Needed! Busy practice located in La Puente. 2-3 days per week. call Dr Kumar 626-968-3793 or pbkumardds@gmail.com.

LOS ANGELES PRACTICE FOR SALE Dr. retiring after 44 years - 3 operatories in approximately 1200 sq. ft. - very modern with digital x-rays -- days hygiene/week - grosses approx. \$400,000 on 4 easy days/week - 2 days hygiene - Thomas & Fees Practice Sales (714) 544-4341.

General Dentist needed for private PPO office in South OC. 1-2 days/week. Email CV to maihrmanager@gmail.com.

bilingual dental assistant needed part time. Saturdays. Upland area RDA or DA. ok. email resume to upslmlctr@dslextreme.com.

Busy office looking for experienced office manager. Email: sunshinedentalgroup06@gmail.com.

We are THE LEADING ADVISORS to more than 15 DENTAL SOCIETIES. See our website for upcoming events/seminars in your area. 800-499-1474 WOOD & DELGADO www.dentalattorneys.com.

2 used Belmont Dental Chairs with cuspidor, all attachments, no units, needs oil, minor repair, \$300 each. call (714) 848-8433.

GET MORE!



The Dental Trader publishes far more ads placed by California dentists and their staff than any other dental publication in the country.
"Nothing says readership like participation of readers!"
Place your free ad today!

INLAND NORTH COUNTY SAN DIEGO: Highly-regarded GP. FFS/PPO. 6 Ops. Beautiful, free-standing building with ample parking. Opportunity for property ownership. Russell Okihara-HSPPT 619-694-7077-#CA271.

CHAIR UPHOLSTERY 15% OFF Expert Stitchwork. Fast Turnaround. Great Rates. Contact Us Today! 877-535-1733 / www.repairmakers.com.

Busy office looking for ENDO/PEDOdontist in Coachella. Email:sunshinedentalgroup06@gmail.com.

General Dentist needed in Baldwin Park. Spanish a plus. New Grads ok. Comfortable in all aspects of Dentistry. Call-626-383-1265 fax-626-962-3551.

Buying a practice? Call today for a free consultation regarding the process and legal issues involved with your practice transition. (888) 776-5384. www.dental-attorney.com.

Sirona Cerec 3 Unit, Scanner Software and Porcelain Blocks. \$1,500.00 OBO. Good Condition 714-672-9000 or breadentalgroup@yahoo.com.

Dental Office for Subleasing 7 Days a WEEK! Tustin CA Office# 714-368-3413 or comfortdentals@gmail.com.

PAINLESS TREATMENT for receding gums! New technique replaces the need for incisions, grafts, sutures, multiple appointments and long term healing. Visit pinholesurgicaltechnique.com.

West LA practice for sale!!! Revenue over 3 mil/yr. Serious buyers only. Rare opportunity. Email toothdocla@gmail.com.

DENTAL EQUIPMENT FOR SALE Including gendex xrays, midmark handpiece delivery system, midmark track-mounted monitors. Email/Call for details. 858-635-6700. SoCalPerioImplant@gmail.com

Massage Dental Chair Made in USA, 150 Color Choices, 10 Year Warranty \$3495. Call (800) 423 - 5657 for more details.

DENTAL PRACTICES WANTED in Los Gatos, Campbell, Mountain View 3-5 operatories. Cash/PPO. Stand along building is preferred. Sellers call Loc Pham, Broker at LCF Financial, Inc. BRE #01875780. (714) 550-7494 or practice@lcfinc.com | LCFPracticeSales.com.

105MM EX Sigma Micro Lens with attached flash for Canon. In great condition. Case included. \$275 415-259-9118.



CALIFORNIA

Specializing in the Selling

Sellers:

We have buyers looking for practices throughout Southern California! Call John & Bob today for your **Free Personal Sales Analysis**

Robert A. Palumbo
Partner
Executive Vice President



Buyers:

We have 3 professional Broker/Agents to assist you in understanding how to purchase a dental office. Call for your **1 on 1 Consultation**

John W. Knipf
President

FEATURED LISTINGS WITH REAL ESTATE

OCEANSIDE – General practice established in 1998 is located in a professional medical dental building. This practice consists of 5 spacious equipped operatories. It's computerized with Dentrax software and digital laser x-ray (1 sensor). Seller is working 2 day/wk with 1 day/wk of hygiene. Sees approximately 18 patients/day. PPO/CASH/HMO. Grossed \$374K in 2014 and Projecting \$355K for 2015. Please contact your CPS Agent for more information. **Property ID #5069.**

SAN DIEGO – Established in 1986 this general practice is located 3 story professional building with ample parking. Seller is currently working 3.5 days/wk with approximately 15 days of hygiene/wk. PPO and Cash only. No HMO. Practice consists of 7 equipped operatories in approximately 2,980 sq ft suite. Computerized with Practice Work software and digital x-ray. Grossed \$1,982,000 in 2014 and Projecting \$1,936,000 for 2015. NET OF \$454K. Great practice.

SANTA ANA – General practice located in a busy 2 story strip mall with ample parking. This practice consists of 4 equipped operatories. Computerized with Dentrax software with digital x-ray (1 sensor). Seller is currently working 3 days/wk and sees approximately 15-20 patients/day. PPO and cash only. No HMO or Denti-cal. Grossed \$437K in 2014. Projecting \$513K for 2015. NET OF \$184K. Please contact your CPS Agent for more details. **Property ID #5075.**

WEST COVINA - Leasehold Improvements and Equipment Only! This practice is located up against the Foothill Mountains less than 1/2 mile off the 10 Freeway for convenient access. The area around our newly built-out office is exploding with growth, and surrounded by too many anchor tenants to mention. Notable are the 450+ new townhomes that are being built right in front of our practice. The practice consists of 7 equipped operatories, 1 plumbed not equipped in a 2,450 sq ft office. It's computerized with Dentrax software and digital X-ray (1 sensor). The Seller is the landlord is willing to negotiate a good lease. Please contact your CPS Agent for more details. **Property #5077.**

Our services are free to buyers, so we encourage you contact us to have a specialist assigned specifically to you to answer your questions and guide you through the purchasing process.

100% FINANCING AVAILABLE TO QUALIFIED BUYERS

Nationwide Toll Free Number: (855)672-3000 • Fax: (714) 333-4444

PRACTICE SALES, INC.

and Appraising of Dental Practices



LOS ANGELES COUNTY LISTINGS

CANOGA PARK (GP) – Price Reduced – Low sales price! This turn-key practice is located in a 3 story medical dental building with ample parking. Established approximately 10 years ago. Seller is currently working 1/2 day/wk with 1/2 day of hygiene. Sees approximately 10 new patients/mo. The practice consists of 2 equipped operatories, x-ray room with chair, small lab room, sterilization room, and private office in an approximately 1,000 sq ft suite. Have some HMO plans. 100% patient referral. Collecting approximately \$10K-\$15K/mo. Grossed approximately \$147K in 2014. There's approximately 500 active patient charts. Excellent opportunity for a first time buyer or a second office. Please contact your CPS Agent for more details. **Property ID #4357.**

CHATSWORTH (GP) – Price Reduced!! Well established practice with 38 years of goodwill located in a single story busy strip mall. Great signage and visibility. Heavy traffic flow. Seller work 4 days/wk with Associate (mainly hygiene) 2 days/wk. Practice consists of 5 equipped operatories, lab room, storage room, Pano room, sterilization room, dark room, and private office in a 1,377 sq ft office with digital cameras. It's computerized with Dentrix software. Minimal advertising. Has reasonable rent payment. Income source is approximately 50% insurance, approximately 49% cash and approximately 1% capitation. Grossed approximately \$866K for 2014. BUYER'S NET OF \$398K. Great opportunity. Please contact your CPS Agent for more information. **Property ID #4537.**

COVINA - Leasehold Improvements and Equipment Only! Great starter practice located on a busy shopping center with plenty of parking spaces. Consists of 3 spacious equipped operatories, lab room, sterilization area, dark room, lounge room (plumbed) and a private office in a 1,680 sq ft office. The major equipment is approximately 9 years old. Has reasonable rent. On a major street with heavy traffic flow. Please contact your CPS Agent for information. **Property ID #5074.**

DUARTE (GP) – Turn-Key practice located in a busy shopping center. Has great signage. Practice consists of 2 equipped operatories, 1 plumbed not equipped in a 996 sq ft office. Seller is currently working 3.5 days/wk and Associate 1 day/wk. Sees approximately 9-10 patients/day. Insurance/Cash/Denti-cal/Cap. It's computerized with DentiSoft software and digital x-ray (1 sensor). Grossed approximately \$139K for 2014 and projecting \$138K for 2015. Excellent opportunity. Low sales price! Please contact your CPS Agent for more details. **Property ID #5048.**

GLENDALE (GP) - Corner location only minutes away from the Rose Bowl and the popular shopping mall, the Americana. The great location with excellent visibility and signage will help continue the growing trend of this practice. The practice consists of 3 equipped operatories with 1 plumbed not equipped in consultation room. It's computerized with Practice Management software and Digital X-ray. Seller works 4 days/wk and Associate 2 days/wk. Sees approximately, 10-16 patients/day. Insurance and cash only. No HMO. Does minimal advertising. Grossed approximately \$509,055 in 2014. Has monthly revenues of \$40K. BUYER'S NET OF \$187,304. Please contact your CPS Agent for more information. **Property ID #5045.**

HUNTINGTON PARK (GP) – Well established general practice with approximately 30 years of goodwill located in a one story strip shopping center. Practice consists of 3 equipped operatories in a approximately 860 sq ft office. Seller is currently working 5 days/wk and sees approximately 9-10 new patients/mo. Insurance/Cash/Denti-cal. Does minimal advertising. Grossed \$203,989 on 2014 and projecting \$215K for 2015. Buyer's net of \$104K. Great practice. Please contact your CPS Agent for more information. **Property ID #5054.**

LAWNDALE – Turn-Key General Practice located in a two story store front building with a large signage that overlooks to the main boulevard. Has over 45 years of goodwill. The practice consists of 4 equipped operatories and 2 plumbed not equipped in a 1,450 sq ft office. Seller is currently working 2 days/wk and sees approximately 13-15 new patients per month. Insurance/Cash/Denti-cal. Computerized with Practice Work software and Digital X-ray. No advertising. 100% patient referral. Long term lease. Great opportunity to take over a good location. Please contact your CPS Agent for more details. **Property ID #5051.**

LOS ANGELES - Price Reduced! – Leasehold Improvements & Equipment Only! General practice located in a multi story professional building. This modern designed practice consists of 3 equipped operatories, sterilization, and private office in approximately 824 sq ft suite. The office is computerized with Easy 2000 software and the equipment is approximately new to 5 years old. There 1 digital sensor. Has a long term lease. It's a great potential for a full time and right buyer. Seller will be focusing on primary practice. Some charts included. Please contact your CPS Agent for more information. **Property ID #4467.**

LOS ANGELES - Leasehold Improvements & Equipment Only! This office is located in the City West District. Practice consists of 3 equipped operatories and 1 plumbed not equipped operator, sterilization area, lounge room, Panorex x-ray room (2 digital sensors), consultation room, lab area, and private office in a 1,702 sq ft suite. Major equipment is approximately new to 7 years old. Have granite countertops and excellent views from the operatories of the city and downtown. Has long term lease. New residential and markets are being built around the building. Next to Good Samaritan Hospital. Great opportunity. Please contact your CPS Agent for more details. **Property ID #5047.**



Alice C. King, V.P.



CALIFORNIA

Specializing in the Selling

LOS ANGELES (GP/PERIO/IMPLANTS) – Beautiful practice located in the very desirable Miracle Mile. The office offers an incredible built out consist of 5 equipped operatories with amazing views to the city. No digital x-ray, however, is completely wired through discrete floor access for all computers and digital x-ray. Major equipment is 5 years and has Dentrix software. Seller is currently working 4 days/wk and sees approximately 14-16 new patients per month. Income source is approximately 20% insurance and approximately 80% cash. The practice was established approximately 18 years ago. Grossed approximately \$431,169 in 2014 and projecting \$444K for 2015. Buyer's net of \$146,926. Great office with a flat rate lease. Please contact your CPS Agent for more details. **Property ID #4489.**

MONTEREY PARK (GP) – Well established practice located in a free standing strip shopping center with easy access to the 60 freeway. Next to a college, medical center and a bank. Has a great signage and heavy traffic flow. The practice consists of 6 equipped operatories in a 3,100 sq ft office. It's computerized with Easy Dental software. Seller is currently working 3 days/wk with GP Associate 5 day/wk, GP Associate 1-2x/mo, Ortho Associate 2x/mo and with 3 days/wk of hygiene. Insurance and cash only. No hmo. Grossed \$1,203,497 in 2014. BUYER'S NET OF \$324K. Great practice. Please contact your CPS Agent for more details. **Property ID #5050.**

NORWALK (GP) - With over 65 Years of Goodwill, this practice is well known in the local community. It is also a corner location, right off of the 5 freeway. Currently while only operating on 1 day a week; it is still driving good numbers. Practice consists of 3 equipped operatories and 1 plumbed not equipped. Note the private office is plumbed, and also has in place cabinetry with a stainless steel sink which could be used for a fourth operatory. Grossed \$289K in 2014. BUYER'S NET OF \$95K. Please contact your CPS Agent for more details. **Property ID #5026.**

PASADENA (GP) - This practice consists of 3 equipped operatories and located in a 2 story professional building with parking structure. It's computerized with Dentrix software and digital x-ray. Suite is approximately 1,150 sq ft. Seller established practice in 2012 and currently working 2 days/wk and sees approximately 9-10 new patients/mo. Insurance and cash only. No HMO. Does minimal advertising. Grossed approximately \$335K in 2014. BUYER'S NET OF \$139K. Great practice with good signage visibility. Near residential community and shopping plaza. Please contact your CPS for more details. **Property ID #5035.**

PASADENA - Leasehold Improvements and Equipment Only! To our knowledge this is the only dental practice located in the beautiful Huntington Pavilion, which is located right next to the Huntington Memorial Hospital. It has a very modern sheik design that you can only truly appreciate by seeing it, and everything through the practice is in immaculate showroom condition. Seller built out the practice approximately 1.5 years ago. Includes an adjacent parking structure. Conveniently located between where the 210 and 110 Freeways. Practice consists of 3 spacious operatories, lab/sterilization combo room, consultation room and a private office in a 1,552 sq ft suite. Has a long term lease. It's great opportunity to establish your practice. Please contact your CPS Agent for more details. **Property ID #5065.**

POMONA – Leasehold Improvements & Equipment Only! This modern designed practice has been known a dental office for over 50 years. Located in a single story professional building with plenty of private parking. The practice consists of 4 equipped operatories, lab room, sterilization area, lounge room, private office and 3 storage rooms in an approximately 1,400 sq ft office. Just minutes away from the 10 freeway. Close proximity to a local hospital, Western University and the Pomona Fairgrounds. Landlord is easy to work with and offers a very rare gross lease (NO common area or triple net fees). Great opportunity for a starter office. Please contact your CPS Agent for more details. **Property ID #5057.**

RESEDA – Well established turn-key general practice with over 50 years of goodwill. This family practice is located in a single story free standing building with ample parking. It's on a major street of Reseda with lots of heavy traffic and excellent street visibility. The practice consists of 3 equipped operatories (stand up dentistry), sterilization/lab combo, dark room, and private office in a approximately 950 sq ft office. Not computerized. Has older equipment. Seller works 4 days/wk and sees approximately 8-20 patients/day. Income source is approximately 30% insurance, 30% cash, 10% Denti-cal and 30% capitation. Grossed approximately \$281K in 2014. Has monthly revenues of \$22K. Seller is retiring. Practice next to a residential community. Please contact your CPS Agent for more information. **Property ID#5017.**

TORRANCE – General practice located in a busy single story shopping center with lots of traffic. Practice consists of 3 equipped operatories, sterilization/lab combo, consultation room, lounge room, and private office in an approximately 1,046 sq ft suite. Computerized with digital x-ray. Seller works 4 days/wk and sees approximately 10-12 new patients/mo. No HMO. Grossed \$324K in 2014. Practice is averaging \$27K in monthly revenue. BUYER'S NET OF \$107,517. Great office. Please contact your CPS Agent for more details. **Property ID #4477.**

Nationwide Toll Free Number: (855)672-3000 • Fax: (714) 333-4444

PRACTICE SALES, INC.

and Appraising of Dental Practices



Robert A. Palumbo, Executive V.P/Partner

TORRANCE – General practice with over 30 years of goodwill located on 3 story medical / dental building. The practice consists of 5 equipped operatories, lab room, sterilization room, storage room and private room in a approximately 1,686 sq ft suite. It's computerized with Easy Dental software and digital X-ray. Does minimal advertising. Seller works approximately 4 days/wk with 2 days/wk of hygiene and sees approximately new 8-9 patients/day. Insurance and Cash only. Grossed \$495K in 2014 with monthly revenues of \$40K. BUYER'S NET OF \$149,439. Great practice. Please contact your CPS Agent for more details. **Property ID #5036.**

WHITTIER – Price Reduced!! Leasehold Improvements and Equipment Only! This modern designed practice is located in a 4 story professional building across the street from a busy shopping center. The practice consists of 5 equipped operatories with 3 monitors w/ Netflix, lab room, lounge room, 3 X-ray room, 2 consultation room, 1 sterilization room and 1 private office in a approximately 2,250 sq ft suite. It's computerized with Open Dental software and digital X-ray (1 sensor). Operatories are plumbed for Nitrous Oxide. Has a long term lease. Networked with security cameras. Great started practice with a spa like atmosphere. Please contact your CPS Agent for more details. **Property ID #5053.**

WEST COVINA - Leasehold Improvements and Equipment Only! This practice is located up against the Foothill Mountains less than 1/2 mile off the 10 Freeway for convenient access. The area around our newly built-out office is exploding with growth, and surrounded by too many anchor tenants to mention. Notable are the 450+ new townhomes that are being built right in front of our practice. The practice consists of 7 equipped operatories, 1 plumbed not equipped in a 2,450 sq ft office. It's computerized with Dentrix software and digital X-ray (1 sensor). The Seller is the landlord is willing to negotiate a good lease. Please contact your CPS Agent for more details. **Property #5077.**

ORANGE COUNTY LISTINGS

GARDEN GROVE – The practice has over 24 years of goodwill to offer. With very convenient freeway access, it is currently located in a single story strip mall and right around the corner from Anaheim Memorial Medical Center. This practice consists of 3 equipped operatories in a 959 sq ft suite. It's computerized with Dentrix software. No digital. Retiring seller is currently working 4.5 days/wk and sees approximately 16-20 patients/day on a busy day. PPO/Cash/Denti-cal. Patient base is approximately 60% young adults. 100% Patient Referral. Grossed \$467K in 2014. Projecting approximately \$497K for 2015. Great opportunity. Please contact your CPS Agent for more details. **Property ID #5066.**

GARDEN GROVE – Well established general practice located in one story free standing building. Corner location with great street visibility on a major intersections of Garden Grove. Seller is currently working 5 days/wk and sees approximately 10-12 new patients/mo. There is currently 2 days/wk of hygiene. Insurance and cash only. NO HMO. Practice consists of 4 equipped operatories and 1 plumbed (not equipped) operator in a 1,500 sq ft office. It's computerized with Dentrix software and digital x-ray. Seller grossed approximately \$436K in 2014 with monthly revenues of \$36K. BUYER'S NET OF \$155K. Great opportunity. Please contact your CPS Agent for more details. **Property ID #5043.**

HUNTINGTON BEACH (GP / Turn-Key) - This practice has 42 years of goodwill and has been remotely run by an absentee owner from New York. It is located in a multi story professional building on a major boulevard with lots of heavy traffic. The practice consists of 4 equipped operatories in a 1,452 sq ft office. It's computerized with Practice Works and digital x-ray. Does minimal advertising. The Associate also being from New York, travels back and forth to New York. The practice needs an owner that can provide a consistent schedule to bring it back to the income level it has historically generated in the range of \$900,000 - \$1,000,000. Great opportunity. Please contact your CPS Agent for more details. **Property ID #5063.**

IRVINE - Leasehold Improvement and Equipment! This spacious well laid out office is located in a two story free standing building next to the Orange County Airport with easy freeway access. It consists of 10 equipped operatories, lab / sterilization room, lounge room, 2 reception areas, 1 Pano x-ray room, and private office in a 3,059 sq ft suite. The major equipment is new to 7.5 years old. This is great opportunity for another practice that has outgrown its location or is looking to expand. Seller is taking the patients to other 5 locations. Please contact your CPS Agents for more information. **Property ID #5030.**

IRVINE – Established approximately 30 years ago, this practice is located in a 2 story professional / medical building. Practice consists of 4 equipped operatories. Two operatories are plumbed for nitrous and oxide. It's computerized with JDent/Light Year software and digital x-ray (2 sensors). Seller is currently working 4 days/wk (part time) with 2.5 days/wk of hygiene. Income source: Insurance/Cash/Cap. Grossed approximately \$135K in 2014. BUYER'S NET OF \$128K. Please contact your CPS Agent for more details. **Property ID #5055.**

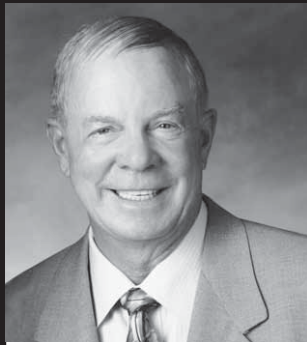

John W. Knipf, President



CALIFORNIA

Specializing in the Selling

IRVINE - Leasehold Improvement and Equipment! The practice is located in a strip mall right next to a food court that has a very high volume of foot traffic. Being across the street from John Wayne Airport, it lends itself to a high volume of traffic in general. The Seller has outgrown this location and has purchased his own building. Has very reasonable rent for the area and the landlord is very easy to work with and has NO affiliation with the Irvine Company. The practice consist of 3 equipped operatories, private office (plumbed), lab & sterilization room, and lounge room in a 1,100 sq ft suite. Please contact your CPS Agent for more details. **Property ID #5056.**

LAGUNA HILLS - Price Reduced!! – Modern designed General Practice with over 15 years of goodwill located in a 5 story medical / dental building. This practice consists of 2 equipped operatories, sterilization/lab combo room and private office (plumbed) in a 1,107 sq ft suite. It's computerized with EagleSoft software and digital x-ray. Seller is currently working 2-3 days/wk and sees approximately 20-25 new patients/mo. Ins/Cash/Cap (~\$500/mo). Grossed approximately \$319,024 in 2014. Buyer's net of \$110,052. Seller will be focusing on family. Please contact your CPS Agent for more information. Great opportunity. **Property ID #5033.**

ORANGE (GP) – Well established practice with 42 years of goodwill. This practice consists of 8 equipped operatories in a 2,640 sq. ft. suite located in a two story free standing building on a busy street. The 2nd floor has a lab, lounge, & office. Attracting approximately 30+ new patients/mo. Intra Oral Camera, Digital X-ray, & Dentrix Software. PPO & Cash Practice. Collected approx. \$819,750 in 2014 w/ a Buyer's Net of \$252K. Please contact your CPS Agents for mode details. **Property ID #5059.**

SAN JUAN CAPISTRANO (GP) – This well established Turn-Key general practice located in 2 story professional building. Excellent location with great street visibility. Close to the center of the community. Well designed, modern office. Practice consists of 4 equipped operatories and 3 plumbed in a 1,947 sq ft suite. Seller is currently working 3 days/wk and sees approximately 20 new patients/mo. Insurance/Cash/Some HMO. No advertising. 100% patient referral. It's computerized with EZ Dental and digital X-ray (3 sensors). Grossed approximately \$241K in 2014. Please contact your CPS Agent for more details. **Property ID #5052.**

SANTA ANA – Leasehold Improvements and Equipment Only + Building Great modern designed practice located in a single free standing building with private parking lot on a major blvd of Santa Ana. The building is for sale. The previous owner was a dentist, and it is known as a dental practice for nearly 20 years. The heavy traffic flow has approximately 30,000 cars that pass up and down the Boulevard on a daily basis. The building has many modern amenities that you can only appreciate after seeing it. The practice consists of 5 equipped operatories with digital x-ray in approximately 1600-1800 sq ft. The equipment is new to older. Please contact your CPS Agent for more details. **Property ID #5062.**

SANTA ANA – General practice located in a busy 2 story strip mall with ample parking. This practice consists of 4 equipped operatories. Computerized with Dentrix software with digital x-ray (1 sensor). Seller is currently working 3 days/wk and sees approximately 15-20 patients/day. PPO and cash only. No HMO or Denti-cal. Grossed \$437K in 2014. Projecting \$513K for 2015. NET OF \$184K. Please contact your CPS Agent for more details. **Property ID #5075.**

RIVERSIDE & SAN BERNARDINO COUNTY LISTINGS

APPLE VALLEY (GP) – Established in 1978 this, practice is located in one story building. It consists of 3 equipped operatories with EagleSoft software and digital x-ray in a 1,350 sq ft suite. Seller is currently working 4 days/wk and sees approximately 15-20 new patients/mo. There is 3 days/wk of hygiene. Insurance and cash only. Does minimal advertising. Remodeled the office in Feb 2014. Has monthly revenues of \$44K. BUYER'S NET OF \$119,285. Great practice. Please contact your CPS Agent more details. **Property ID #5044.**

CHINO HILLS - Leasehold Improvement & Equipment Only! This dream practice was built out when a rare opening in the Costco Center became available. Everything is completely new, and built out exquisitely. Over \$8,000 was invested in just the frameless glass frontage, giving maximum exposure to the restaurants and retail store next to, and surrounding our practice. There is more traffic in the parking lot, than many major intersections in the area. The practice consists of 3 equipped operatories, 2 plumbed not equipped, lab & sterilization area, lounge room, storage room, consultation room, dark room, and private office in a ~1,470 sq ft suite. Move on your dream practice now, or it will be somebody else's! Area is surrounded by residential homes. **Property ID #4501.**

Nationwide Toll Free Number: (855)672-3000 • Fax: (714) 333-4444

PRACTICE SALES, INC.

and Appraising of Dental Practices



Tony Frechette, V.P.

INDIAN WELLS – Great opportunity. This modern designed practice consists of 4 equipped operatories, lab room, lounge room, Cat Scan + Pano x-ray room, 2 consultation rooms, sterilization area, dark room and 2 private offices plus lecture room in a 2,850 sq ft office. Computerized with Intra oral camera. Major equipment is 10+ years old. Seller will be focusing on his primary offices. Located on a one story building near shopping plazas and residential community. Grossed \$360K for 2014 on 1 day/wk schedule. Please contact your CPS Agent for more information. **Property ID #5041.**

MURRIETA - Well established general practice located in a 2 story medical dental building. Practice consists of four equipped operatories in a 1,350 sq ft suite. It's computerized with Easy Dental software, digital x-ray and intra oral camera. Seller work 1.5 days/wk each, Ortho 1x/mo with 2 days/wk of hygiene. PPO and Cash Only. Averaging 30 new patients per month. Grossed \$588K in 2014 and projecting \$560K for 2015. Buyer's net of \$184K. Please contact your CPS Agent for more information. **Property ID #5061.**

PALM DESERT – Well established general practice located in a free standing building. This modern designed practice consists of 5 equipped operatories in a 2,350 sq ft office. It's computerized with Genesis software. 100% patient referral. Seller is currently working 4 days/wk and sees approximately 15-20 new patients/mo. Has 8 days/wk of hygiene. Insurance and cash only. Grossed \$1,139,675 in 2014. Buyer's net of \$361K. Refers all specialty. Seller is moving out of state. Great opportunity. Please contact your CPS Agent for more details. **Property ID #5058.**

PALM SPRINGS – General practice established in 2005 and located in a one story free standing building. Practice consists of 3 equipped operatories with Practice Web software and digital x-ray. Major equipment is approximately 2 years old. Suite is 1,200 sq ft. Seller is working 5 days/wk and sees approximately 8-10 patients/day. Income source is approximately 25% insurance, 65% cash and 10% Denti-cal. Does little advertising. BUYER'S NET OF \$181K. Please contact your CPS Agent for more information. **Property ID #4487.**

SAN DIEGO & IMPERIAL COUNTY LISTINGS

EL CENTRO (GP + BLDG) – Well established family owned practice with over 60 years of goodwill. This practice is located in a single story building. Building is for sale. Practice consists of 5 equipped operatories, lab room, lounge room, storage, x-ray room, sterilization room, dark room, and 2 private offices in a 1,857 sq ft office. It's computerized with SoftDent software and digital x-ray. Seller is currently working approximately 4.5 days/wk and sees approximately 12-15 new patients/mo. Fee for service. Grossed approximately \$304K for 2014. Buyer's net of \$87K. Great practice. Please contact your CPS Agent for more details. **Property ID #5023.**

OCEANSIDE – General practice established in 1998 is located in a professional medical dental building. This practice consists of 5 spacious equipped operatories. It's computerized with Dentrix software and digital laser x-ray (1 sensor). Seller is working 2 day/wk with 1 day/wk of hygiene. Sees approximately 18 patients/day. PPO/CASH/HMO. Grossed \$374K in 2014 and Projecting \$355K for 2015. Please contact your CPS Agent for more information. **Property ID #5069.**

SAN DIEGO – Established in 1986 this general practice is located 3 story professional building with ample parking. Seller is currently working 3.5 days/wk with approximately 15 days of hygiene/wk. PPO and Cash only. No HMO. Practice consists of 7 equipped operatories in approximately 2,980 sq ft suite. Computerized with Practice Work software and digital x-ray. Grossed \$1,982,000 in 2014 and Projecting \$1,936,000 for 2015. NET OF \$454K. Great practice. Please contact your CPS Agent for more details. **Property ID #5072.**

KERN, SAN LUIS OBISPO & VENTURA COUNTY

BAKERSFIELD - The practice offers over 18 years of goodwill, and is a standing landmark known for its dental services. Located in a medical hub center for the city, the practice is across the street from the area's hospital, and conveniently located next to a pharmacy. The building owner who is also a dentist, occupies the other half of the free standing building, and very easy to work with. With a great rent, easy to work with landlord, and room to even expand further. Practice consists of 6 equipped operatories, 1 plumbed not equipped in a 1,800 sq ft suite. Computerized with EagleSoft software and Digital X-ray. Insurance/Cash/Cap. Seller works 1 ½ days/wk, 2 Associate 1 day/wk each. 100% patient referral. Grossed \$350,014 in 2014 and Projecting to do \$358,000 in 2015. Buyer's net of \$108K. Great potential for full time buyer. For more information, please contact your CPS Agent. **Property ID#5060.**



CALIFORNIA PRACTICE SALES, INC.

Specializing in the Selling and Appraising of Dental Practices



Fred Vuittonet, Real Estate Agent

Dan Parnell, Real Estate Agent



SAN LUIS OBISPO COUNTY – Beautiful well established practice located in a two story medical / dental building. Seller works approximately 4 days/wk, Endo 2x/mo and with 8 days/wk of hygiene. Sees approximately 60 patients/mo. Insurance and cash only. The practice consists of 6 equipped operatories, lab room, lounge room, storage room, consultation room, large sterilization room, and large private office in a 2,626 sq ft suite. It's computerized with EagleSoft software and digital x-ray. Has monthly revenues of \$95K. Buyer's net of \$323K. Excellent opportunity. Please contact your CPS Agents for more information. **Property ID #5037**

SIMI VALLEY (GP + Buildings for sale) - Great opportunity to invest in a general practice and real estate. There are two single stories free standing buildings, which the second property also includes a tenant in a separate detached building which generates rental income. Established in 1964, the 1,900 sq ft. practice consists of 4 equipped operatories with 2 that are plumbed, but not equipped and digital x-rays. It's computerized with Dentrix / Gendex software. Seller is currently working 3 days/week with 2 hygiene days. No advertising. With local business development in process, the potential for growth in the area and within the practice are very high. Grossed approximately \$273,790 in 2014. Has a Buyer's Net of \$124K. Please contact your CPS Agent for more details. **Property ID #5027.**

VENTURA (GP) - This practice has 36 years of goodwill located in a 2 story professional building (1st floor w/ direct access). Modern designed practice with 4 fully equipped operatories in a 1,862 (+ free bonus room) sq ft suite. Every operatory has dual monitors and lights suspended from above making the operatories even more spacious than they already are. Each operatory has floor to ceiling windows for plenty of natural light with custom shades. Computerized with Dentrix software and digital x-ray. Equipment is approximately 2-15 years old. Seller is currently working 4 days/wk with 3 days/wk of hygiene. See approximately 14-16 patients/day. Insurance and cash only. Grossed approximately \$423K in 2014 with monthly revenues of \$35K. BUYER'S NET OF \$92K. Great practice. Please contact your CPS Agent for more information. **Property ID #5039.**

SPECIALTY OFFICE LISTINGS

ALISO VIEJO (Pedo) – With over 20 years of goodwill this practice is located in a two story medical / dental professional building with free ample parking lot. Seller currently works 4 days/wk and sees approximately 10-15 new patients/mo. There is some HMO. Minimal advertizing. Practice consists of 3 chairs in open bay with large window views, 1 plumbed not equipped op, lounge room, video game room, storage room, x-ray room, quiet room, sterilization room and private office in a 2,093 sq ft suite. It's computerized with SoftDent software with digital x-ray. Major equipment is new to older. Grossed \$325,972 in 2014. BUYER'S NET OF \$108,648. Great practice. Nice staff. Kid friendly. Please contact your CPS Agent for more details. **Property ID #5031.**

SIMI VALLEY (Ortho) - Practice consists of 6 chairs in open bay. It's computerized with Orthoware software. Seller works approximately 1 day/wk. Sees approximately 25-30 patients/day. Full service practice. Located in a 1,260 sq ft suite on a two story shopping center. Grossed approximately \$221K in 2014. Please contact your CPS Agent for more information. **Property ID #5003.**

Keep Up To Date with Us on Facebook - <http://facebook.com/MYCPSTEAM>

View Select Videos on You Tube - <http://youtube/MYCPSTEAM>

Need CE Credits?

View Upcoming Continuing Education Opportunities

<http://www.calpracticesales.com/blog>

SELLER'S:

DIRECT E-MAIL ADDRESS TO BROKERS/AGENTS

John W. Knipf: jknipf@calpracticesales.com

Robert A. Palumbo: rpalumbo@calpracticesales.com

BUYER'S:

DIRECT E-MAIL ADDRESS TO BROKERS/AGENTS

Alice King: aking@calpracticesales.com

Tony Frechette: tfrechette@calpracticesales.com

Dan Parnell: dparnell@calpracticesales.com

Fred Vuittonet: fvuittonet@calpracticesales.com

John W. Knipf (Neff) President & Robert A. Palumbo, Executive V.P./Partner • Also serving you: Alice C. King, Tony Frechette, Dan Parnell & Fred Vuittonet

Nationwide Toll Free Number: (855) 672-3000 • Fax: (714) 333-4444

www.calpracticesales.com

CA DRE #00491323

Is your ad missing? Check the automated confirmation you received via email when submitting your ad, see if you exceeded 20 words w/o paying, forgot to include your phone number or email address. Did you miss the deadline? It's always the 7th of the preceding month.

Starter practice for sale in Wilmington business square. Excellent visibility & foot traffic. 4 ops, digital x-ray ready. Call 310-241-7576.

\$\$\$\$\$\$ NEED MONEY FAST? Sunwest Bank can close your dental practice deal quickly. Call 714-730-4412.

State of art dental office in West LA, Westwood Village available for rent. for information email to: drsoleimani@hotmail.com.

Need your plans completed correctly and ready for the city by a Certified Interior Designer? All County Construction. 714-240-7179.

Associate DENTIST needed for Thursdays in Moreno Valley. Experienced in all phases of dentistry. Please email resume to fdc22940@gmail.com.

Buying A New Practice Call Bob Affleck for your practice financing needs 949-939-4550.

WEST HOLLYWOOD General Dentistry. 4 Ops, Professional Building, Digital, \$623K GR in 2014. HSPPT-Kerri McCullough 949-566-3056-#CA212.

WANTED Current address of Kurt Conrad dba: Conrad Capital Kurt Conrad-Director of Professional Lending aka: Rep OZARKS CAPITAL FUNDING Last known address: 45751 Rancho Palمراس, Indian Wells, CA 92210 www.ocflink.com email: kurt.conrad@ocflink.com Ph: 949-300-2433 Fax: 949-759-0746. Please contact Bruce at The Dental Trader if you know the current whereabouts of this former advertiser. Thank you. 877 888 4237.

Board Certified Oral Surgeon needed in dental office in Laguna Hills for about one day a month. (949) 297-6241.

3 ops Digital Xray,paperless(Eaglesoft). f/t Hygiene. 4d/week.2014 collection \$540K. asking \$380k. Lake Elsinore. 763-587-8345.

We as Dental Attorneys like to GIVE BACK to the Dental Community. With over 30 lectures per year we strive to provide the knowledge you need to make the BEST decision for your future! 800-499-1474 WOOD & DELGADO www.dentalattorneys.com.

Glendale Prestigious high-tech general and cosmetic practice. Real estate available also. IntegrityPracticeSales.com, Broker Bill Kimball, DDS, BRE #01911548. (855) 337-4337. SAN LUIS OBISPO Perio practice. 4 ops. Upscale equipment. Purchase the full practice or half. IntegrityPracticeSales.com, Broker Bill Kimball, DDS, BRE #01911548. (855) 337-4337.

General Dentist looking for a P/T position. 5+ years experience. Fast Paced & great chair side manner. smileyca@gmail.com.

Nobody wants to sue...or defend against a lawsuit, but they are a fact of life. Deal with enough people, you are bound to end up in court. On that day, Kerendian & Associates is the firm you want representing you. 888-299-7848.

Practice Management Software with Digital Sensors. Perfect for the new office or office looking for a clean/fresh new start. Call 1(800)397-6046.

www.DentalLawyers.com The Most Trusted Firm by Dentists and Dental Professionals. We are a firm of attorneys specializing in dental transitions, dental leases, dental partnerships, dental groups and all business needs of a dentist. Please call for a free consultation (949)852-7301.

FOR SALE Columbia Typodont. Dental Study Model. Used for dental school. \$80. Email for pictures. gaw1177@gmail.com.

PRACTICE FOR SALE Mira Mesa. 20+ yr GP, 4 Ops. in 1300 sq.ft. PPO: SDPS: 760-599-7828.

VICTORVILLE General Dentistry, 6 Ops, 3 Equipped. SoftDent, 34 years of Goodwill. \$313K GR and \$147K Adj. Net. HSPPT-Kerri McCullough 949-566-3056-#CA149.

Seeking FRONT DESK STAFF in UPLAND CA with Experience in general and specialty dental offices. E-mail your resume to: Magday60@Gmail.com

Pursuing ownership? Live Oak Bank can finance your dental practice with customized loan terms and quick credit approvals. 877.890.5867 www.liveoakbank.com/healthcare Envision your dream practice. Now let us make it a reality. Contact Live Oak Bank for your practice financing needs. 877.890.5867 www.liveoakbank.com/healthcare.

STATIM 2000 G4 Autoclave, Like New, Cost \$5,179. Make Offer. Call 855-772-7645 or email janetm@hygiacare.com.

Failed molar Endo Need Apicoectomy, broken file? No worries. Call me, I come to you. 562-968-4061 www.socalrootcanal.com.

FOR SALE 6" Wireguard for digital sensor USB cord insulation. For Sale \$25. MSRP \$50. Email for pictures. gaw1177@gmail.com.

DENTAL PRACTICE FOR SALE TORRANCE: Busy Shopping Center. Proximity to Freeway. Low Selling Price. Call Broker - Practice Sales & Appraisals (818) 999-9595.

FACT An ADA study demonstrated that 1 out of 3 dentists will be disabled long enough to collect benefits. Call us for a FREE Disability Insurance Appraisal 855-346-9729 di4dds.com.

X-ray film developer AT2000 Air Techniques, Good working condition, \$450.00 B/O Call 530 613 8467.

PRACTICE FOR SALE LOS ANGELES LH w/ 3 eq ops 1 pmbd in 1,702 sqft ste California Practice Sales, Inc. Phone: 714-639-2775.

Experienced Fun, Ethical, and Skilled General Dentist available part time in the San Fernando Valley. 6+ years. Please email Sfvdentist8@yahoo.com.

Small high quality Noho office seeking part-time endodontist or general dentist for endo cases. 818-769-3039.

SOUTH RIVERSIDE COUNTY BUSY SHOPPING CENTER LOCATION W/ EXCELLENT SIGNAGE. History of collecting \$1 Million + for the last 3 years. Pride of Ownership! Call Greg Beamer, Dental Broker 909-542-4891.

HANDS-ON Surgical Course

Surgical Extractions, Bone Grafting, and Implant Placement

Limited availability. Sign up today! 4 CE UNITS

- Learn comprehensive treatment planning.
- Learn to perform difficult extractions and proper bone regeneration techniques.
- Learn the surgical placement of dental implants on pig jaws.
- Learn implant prosthetic phase.
- Learn how to manage surgical and prosthetic complications.
- Increase case acceptance.

Hands-on Course Tuition:

Only \$499

Hands-on Course Includes:

4 CE Units, all surgical materials, implants, and pig jaws.

COURSE DATES:

Saturday, August 15, 2015
 Saturday, September 12, 2015
 Saturday October 17, 2015
 Saturday, November 14, 2015



100% of the profits from the course are used to treat our veterans and neglected older adults living below the threshold of poverty.



This course is being conducted by a team of experienced board-certified oral surgeons, prosthodontists, and periodontists, and led by Dr. Charles Zahedi. Dr. Zahedi is presently a part of the faculty at the Department of Periodontics at the University of California, Los Angeles and was a full-time Associate Professor at the Department of Advanced Periodontics and Implant Surgery at Loma Linda University. He has been extensively involved with dental implants since 1990 and has trained hundreds of dentists around the world from Europe, Asia, South America, and the United States. Dr. Zahedi is the founder and clinical director of Dentists for Veterans and the Oral Disability Rescue. These nonprofit organizations have initiated the first nationwide study on veterans and prevention of abuse on older adults, bringing about awareness of the importance of oral health care for every individual.

Call Now 888.871.0009

info@implantmentoring.com | www.implantmentoring.com | www.implantoutreach.com

©2015 Implant Outreach Inc. All rights reserved. Implant Outreach® is a registered service mark. Do not Quote, Cite, Use or Reproduce Without Written Permission of Implant Outreach Inc.

Buy it! Sell it!! Trade it!!!

Looking for experienced front office staff for 4 locations: B.H., Woodland Hills, Mission Hills & Santa Monica.
farahkam@sbcglobal.net.

West Covina Starter Practice collected \$200,000 in 2014 and \$100,000 for the first 4 months of this year. Free standing building. 3 equipped ops. Asking \$120,000. Kurt Skarin 805-777-7707.

IN HOUSE PERIODONTIST AVAILABLE. ALL SURGERIES AND IMPLANTS. BOARD CERTIFIED. IV SEDATION. HAS ALL INSTRUMENTS AND ASSISTANT. GENTLE AND CARING. 8185214947. DENTALPLUSPERIO@GMAIL.COM.

Reliable front office dental assistant needed with xray license and fluent in Spanish. Email resume to dental1717@gmail.com.

Looking for experienced front office staff for 4 locations: B.H., Woodland Hills, Mission Hills & Santa Monica.
farahkam@sbcglobal.net.

Custom built stools Big seat, little seat, tall or short. We can fit any human...Superior Upholstery Company 888-548-7282 superiorupholstery.com.

PERIODONTIST WANTED! Beautiful, modern established Endodontics practice in the San Fernando Valley with a large referral base is looking to share the office with a periodontist. Please Email resume to: uscendo87@gmail.com.

Need: Dentist RDA-Bilingual, Spanish-English Ontario, CA email: anavrios@yahoo.com-FX(909)933-6801.

S. ORANGE COUNTY Pedodontic Practice. 4 Ops, 1 year new equipment, OpenDental, Digital, Pano. \$236K GR w/room to grow. HSPPT-Thinh Tran 949-533-8308-#CA222.

DENTAL STOOLS Dr. and Assistant stools, various brands, good condition. (8 total) \$50 each. 310-275-4656 or dds1984@sbcglobal.net.

I have had the pleasure of working with Monica Rebella and her Rebella Accountancy as my accountants for the past 15 years. She is truly the most knowledgeable and professional accountant I have come across all these years. She is simply always available for you and for any of your questions. Shay Salehrabi D.D.S. (714) 619-0667
www.rebellacpa.com.

DENTAL CHAIR Pelton & Crane Chairman 5000 recently recovered. Good working condition. (Quantity 2). \$1000 or best offer 310-275-4656 or dds1984@sbcglobal.net.

Receptionist needed for dental practice for recalls, post-op & comfort calls in Orange County CA.
greatdentistry2015@gmail.com.

Orthodontist looking to rent space in Peds/Pediatric office or work a different arrangement. Please contact me hollywoodsmilebuilder@gmail.com.

CLOSING OFFICE Newer equipment, chairs, lights, vacuum, everything must go. Great prices. Email: cruscagl@netzero.net.

Legal Tip Does it matter whether the sale closes this or next year? Attorney Robert W. Olson, Jr., 805.963.1120, www.transdental.com.

LICENSED DENTIST SEEKING HYGIENE ONLY POSITION. humble, team-player, thorough/gentle, increase case acceptance, great chair-side manner. aman32dmd@gmail.com 714-470-8231. Dr.Singh.

Brand New "turnkey" 4-op dental office in Tustin/Santa Ana area for lease. greatdentistry2015@gmail.com.

Office in Arcadia selling a Zoom Advanced Power bleaching machine. \$150.00 or best offer. Please call 626-446-3023.

Encino practice for sale, 3 ops, view, reasonable price, associate run. Good for startup, merger, or specialist. For info: fish486@aol.com.

PT/PT position available for lead RDA with min 2yrs experience. Bilingual+. Send resume to capistranodental@gmail.com or call (949)487-3273.

Leasehold Improvements for sale. Foothill Ranch 1,200 sq ft, 3 rooms. 5 yr lease avail. Call Kim 949-246-9494.

ORTHODONTIST WANTED \$1200-1500/DAY. THURSDAYS AND TUESDAYS. ANAHEIM, SOUTH BAY, AND CERRITOS. FAX: 310-878-0277 OR EMAIL: socalteeth@gmail.com.

COLLEGE AREA, SAN DIEGO Very busy 6 Op General Practice with room to expand to 9 Ops. PPO, Dentrax, Digital. 2014 GR 1.7M. Russell Okihara-HSPPT 619-694-7077-#CA231.

SPACE FOR LEASE Looking for dental specialist. GP and orthodontist in the building. Centrally located in Valencia, CA. Call 661-607-6031.

2005 Cerec Redcam Scanner/Mill. 17k minutes. Works great. Block supply incl. Pickup only, South County: \$6000. Call 949.495.6677.

ADD \$250,000 TO YOUR YEARLY PRODUCTION! Request Our Free Production Building Guide Specifically Formulated For Practice Owners and Associates. profitableGPs@hotmail.com Tel: (310) 699-3441.

For Sale Zoom light with stand, looks and works like new. Spare lamp head included. \$800 OBO 949-495-6677.

RDA looking for work in av area or Santa clarita please contact 6618600265.

WOODLAND HILLS PRACTICE FOR SALE - Dr. retiring after 38 years due to a medical condition- 8 operatories in approximately 2000 sq. ft - very modern with digital x-rays-14 days hygiene/week - grosses over \$2,200,000 on 4 days/week - Dr. refers endo, oral surgery, perio and implant placement- Seller willing to stay to do exams, consultations, and treatment plans -Thomas & Fees Practice Sales (714) 544-4341.

In house PERIODONTIST Increase your income in this tough economy. Highly skilled in all surgical procedures and implant placement. 424-645-7173.

Immediate Opening Experienced with HMO's/PPO's Dentrax, Dexis, self motivated team player, excellent customer service. Punctual, Email: DrTGonzales@aol.com.

UCLA BOARD CERTIFIED PERIODONTIST AVAILABLE FOR YOUR OFFICE. EMAIL AT PERIODONTALEXP@YAHOO.COM. WILL BRING ALL INSTRUMENTS.



CPA DDS
Wiederman & Potter
 PREMIUM PRACTICE SALES

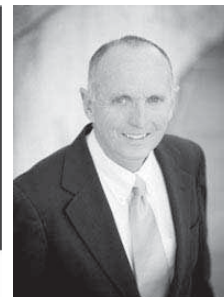

Art Wiederman, CPA, CFP
 Broker #01511095

1415 Warner Ave., Suite C ~ Tustin, CA 92780
 714.259.0501 ~ 714.259.0406 f info@wppps.com ~ wppps.com

Phil Potter, DDS, FAGD
 Broker #01780656

YOUR BRIDGE TO A SUCCESSFUL TRANSITION

Premium Practice Listings

Los Angeles Area PERIO #1090

Outstanding periodontal practice in a premier location, five (5) treatment rooms, 1,500 sq ft, seller retiring, projected gross for 2015 over \$1 million.

Asking \$595,000

PERIODONTAL Practice #1092

San Francisco Bay Area, all digital, annual profit over 55%, 2014 Gross over \$1,600,000

Asking \$700,000

Coastal Orange County #1079

Beach Location, 1,100 sq. ft., over 40 years goodwill, seller owned building great lease, 2014 revenues 524,000

Asking \$385,000

San Diego County #1093

Fee-for-Service restorative practice, shopping center location, five (5) treatment rooms, seller retiring, digital x-ray, laser, and intraoral cameras, 2014 revenues \$531,260

Asking \$385,000

North Central Los Angeles #1100

Restorative cash fee-for-service practice, contemporary suite/ all digital, 2015 Projected revenues over \$770,000

Asking \$575,000

North Los Angeles County #1097

General esthetic and restorative practice, turn-key, nine treatment rooms, all digital, seller retiring. 2014 revenues \$1,708,000

Asking \$1,275,000

Fresno County #1091

Outstanding general dental practice and dental building for sale, approx. 2,400 sq ft., six (6) treatment rooms, practice fully equipped with digital x-ray equipment, seller retiring, practice gross in 2014 \$535,000.

**Asking \$347,500 for Practice
 Asking \$695,000 for Building**

South Orange County #1099

Restorative fee-for-service practice, five (5) equipped treatment rooms, contemporary 2,000 sq ft., digital x-ray, lasers, intraoral cameras, 37 years of goodwill, seller will work-back, 2014 Gross revenues \$1,426,236

Asking \$1,300,000

So. Orange County #1048

Beautiful digital office two asgn restorative fee-for-service practice in busy shopping center, seller retiring, 2014 revenues \$832,000

Asking \$549,000

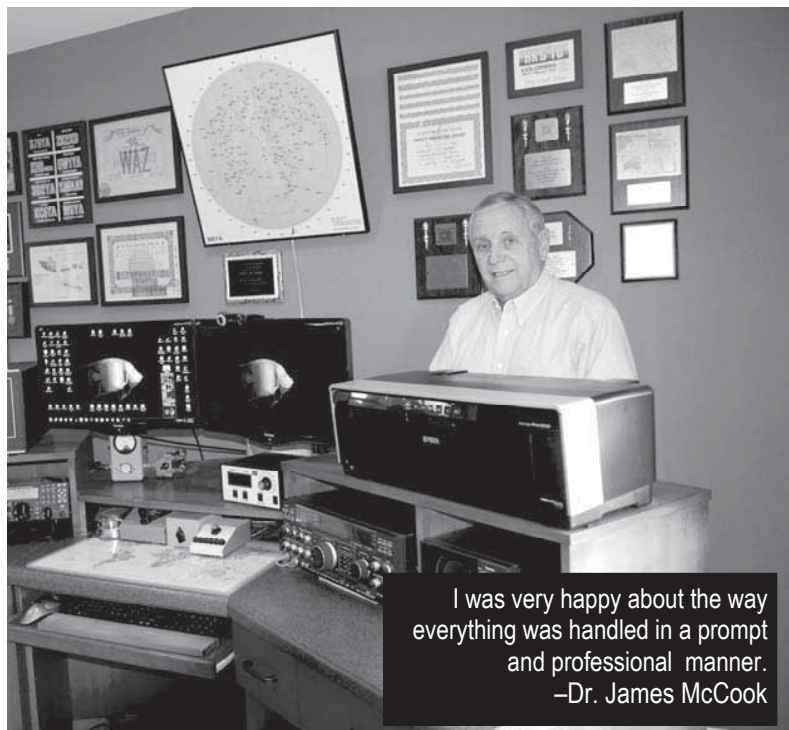

I was very happy about the way everything was handled in a prompt and professional manner.
 —Dr. James McCook

Ocean Beach Prime high visibility corner located on Ocean beach's busiest street. Very low overhead with no marketing being done. 35 years of goodwill. Fee for service and PPO only. Only four blocks from popular San Diego beach. Ken Rubin Practice Sales (619) 299-6161.

Part-time General Dentist needed in Valley Village. All applicants will be considered but Spanish speaker preferred. Letty at (818)769-1347.

Female DDS seeking hygiene position in or near Orange County. Flexible hours/days. Reliable, friendly. 714-348-3491.

Hospital Grade Synthetic exam gloves \$39.68 per case of 1,000, Nitrile "Sensicare Silk" exam gloves \$171.05 per case of 2,500 (boxes of 250). That's \$.07 per glove! www.dentalprodx.com.

ENDODONTIC OFFICE MANAGER NEEDED Downtown Los Angeles. Experience Required. Bilingual Preferred. Send CV to RootCanalDMD@Gmail.com or Fax 213.481.1156.

TEMECULA Looking for dental associate to buy in/buy out in a year or sooner. Please email dentalmin2005@yahoo.com.

PRACTICE FOR SALE ALISO VIEJO Pedo office w/ 20+yrs goodwill NET \$108K California Practice Sales, Inc. Phone: 714-639-2775.

FOR SALE Hu-Friedey Sidekick Automatic Scaler Sharpner. Used only a few times. \$179. Email for pictures. gaw1177@gmail.com.

N. COUNTY SAN DIEGO-COASTAL: General Dentistry, 3 Ops, Dentrax, FFS/PPO. Desirable location. 2014 GR \$530K. Russell Okihara-HSPPT 619-694-7077-#CA253.

Great Newport Beach Location- Beautiful operatories for sublease for starters/new grads if you wish to start your own practice without capital.
Behnamlaw@yahoo.com.

General Dentist wanted for PEDO office in Santa Ana. Pay base Or 30% of collection. Send Resume to: Richardreal88@gmail.com.

PEDODONTIST WANTED! A FAMILY PRACTICE IN SANTA CLARITA IS LOOKING FOR A PEDODONTIST TO SEE YOUNGER PATIENTS. 562-756-2573. DR. PARK.

DENTAL PRACTICE FOR SALE IRVINE: Long Established Private Practice. Active Hygiene Schedule. Seller Retiring. Call Broker - Practice Sales & Appraisals (818) 999-9595.

P/T Dentist wanted 2-3 days per week fast growing practice in La Puente. Contact Dr Kumar @ 626-968-3793 or pbkumardds@gmail.com.

"Jason As frustrating as this whole situation was, I don't feel like I missed out on anything. Everything about this deal was sketchy from beginning to end. However, I wanted to thank you for all of your help because you constantly helped me from making irrational decisions out of fear and impatience."
NANCY NGUYEN, DDS New York, New York WOOD & DELGADO www.dentalattorneys.com.

Thank you very much for helping me through this and making the process so easy for me. - Safa Khaleel DDS, Mountain View, CA. www.TheDoctorsInsuranceBroker.com, jonathan@tdibroker.com or call 800-767-0864.

SAVE YOURSELF SOME TIME



Read The Dental Trader online.

All those email and website addresses are hyperlinked when you view the publication in pdf format.

Click on **EDIT**, then on **SEARCH** to quickly locate something specific. Online readers get a ten day jump on those who wait for it to arrive in the mail and score the best bargains.

Part time GP or Hygienist 1 or 2 days at Irvine California must speak Mandarin Please text (949)421-7898.

San Fernando Valley perio practice collects \$880,000/year with a net income of \$265,000. Four days of hygiene per week. 5 ops. Asking \$475,000. Kurt Skarin 805-777-7707.

HANDPIECE (Midwest #07-042-8854) Like New, Cost \$799, Make Offer. 855-772-7645 or janetm@hygiacare.com.

ICW White Monitor/Keyboard Mounts(5) Good Condition Contact Jeff 949 246-5227 to see pictures.

CLOUD BASED TELEPHONE SYSTEMS for Dental Offices. Simple, flexible, and powerful voice and data solution at a very affordable price. Cutting edge technology allows dental offices to utilize a fully hosted PBX and offer you the latest phone and Internet technologies without the need and cost to purchase your own onsite PBX. Call 800-273-5033. Or visit: www.eZ2000dental.com, then PRODUCTS, then TELEPHONE / INTERNET SYSTEMS.

Orthodontist needed 1 Saturday a month in Carson, Ca. Send CV to caredental4you@gmail.com.

"Increase the value of your dental practice by filing for federal trademark protection. Call today for your free consultation." Law Offices of Amy L. Borden, Esq. (888)416-1321. www.californiadentalattorney.com.

Looking for an associate dentist 1-2 days/week, all aspects of dentistry in Carson, Ca. Send CV to caredental4you@gmail.com.

Mention this ad and get half off your closing costs.[†] Offer ends December 31, 2015.



Practice Sales and Acquisition | Start-ups | Debt Consolidation
 Deposits | Practice Relocations | Equipment and Consulting Financing
 Merchant Services | Payroll and Cash Management | Small Business Card

Flexible financing meets important insights

2013 & 2014 Townie Choice Award Winner for Best Practice and Equipment Financing

With Bank of America Practice Solutions, you get financing* and guidance that matches your needs

Over the years, we've helped thousands of dental practices become more efficient, productive and successful. We'll sit down with you, ask lots of questions and ensure that we totally understand your needs. Then, we'll develop a financial package that's customized to your practice.

Call now and we'll give you a **complimentary Dental Practice Business Plan** that can be invaluable to your business.



Let's talk



Matthew Christie – 949.794.7440
 matthew.christie@bankofamerica.com

Practice sales and acquisition



Ali Karjoo – 949.794.7447
 ali.karjoo@bankofamerica.com

Start-up, commercial real-estate and construction projects

To learn more, visit bankofamerica.com/practicesolutions



Practice Solutions

Bank of America



[§] CDA stands for California Dental Association.

[†] This offer does not include commercial real estate products.

* All programs subject to credit approval and loan amounts are subject to creditworthiness. Some restrictions may apply. The term, amount, interest rate and repayment schedule for your loan, and any product features, including interest rate locks, may vary depending on your creditworthiness and on the type, amount and collateral for your loan. Bank of America Practice Solutions may prohibit use of an account to pay off or pay down another Bank of America account.

Bank of America is a registered trademark of Bank of America Corporation. Bank of America Practice Solutions is a division of Bank of America, N.A.

©2015 Bank of America Corporation | ARMYKXPM | Rev. 05/15

Our 8th Annual Dental Skills Series in OC includes 2 Lectures + a Hands-on Direct Composite Veneers Course...only \$449 and 21 CEs! Visit www.xcelseminars.com for info.

Periodontist Needed!! for a growing Multi practice company. Must have a Valid California license & 3yrs + experience. We offer very competitive compensation programs please email resume to rocio@assuredentalcare.com.

N. ORANGE COUNTY General Dentistry, 7 Ops, 6 Equipped, 2,700 sq.ft. suite. \$542K GR in 2014 with \$258K Adj. Net on a 3 day work week. HSPPT-Kerri McCullough-949-566-3056 #CA248.

1 in 5 dentists practicing in the U.S. is licensed and practicing here in California and they advertise and read The Dental Trader. Free ads for dentists and staff. Visit <http://thedentaltrader.com/faqs.htm>. How can we help you?

Life Time Warranty!!! Perfectionist, Fast, Caring & Patient-Friendly: Keep All Complicated Endo Your office Sends Out, visit: www.socalrootcanal.com.

Medical/Dental spaces for lease at 9241 Reseda Blvd in Northridge. Recently remodeled building. 818 709-8645 drgrupp@aol.com.

Seeking to buy used equipment for new office. Need autoclave, ultrasonic, x-ray sensor, basically everything except chair and compressor. lancedo@mac.com.

10 TEETH IN 1 HR...correct receding gums without the pain, limitations, post-procedure risks and healing of grafting. 24 hour recovery period, results visible on day of treatment. Visit pinholesurgicaltechnique.com.

2 Beautiful offices available to sublease. In Studio City and Downtown Los Angeles. 213-623-2212.

DENTAL PRACTICES WANTED in Orange County & LA \$300K-500K Gross Collection. Existing practice, 4-6 Operatories. Shopping center is ideal. Sellers call Loc Pham, Broker at LCF Financial, Inc. BRE #01875780. (714) 550-7494 or practice@lcfinc.com | LCFPracticeSales.com.

Dental office Lompoc, new, accepts denti-cal, approximately 600 charts, 2 chairs... only \$200k, open 2.5 days/wk.(805)720-3555.

Office manager needed for busy private office. 1+ year exp. contact: sunshinedentalgroup06@gmail.com.

PALM DESERT Perio/Implant/Prosth, 6 Ops, Dentrax, Digital, Pano. \$805K GR, Adj. Net of \$386K. HSPPT-Thinh Tran 949-533-8308-#CA242.

E4D CAD/CAM System includes Design Cart, Computer, Mill, Compressor, Oven, e.Max and Empress Blocks, Accessories. (530)628-4271 jwkii@hotmail.com.

Professionalism respectful and diligent to my project. All County did an exceptional job. Dr. M. Yung. 714-356-1203.

Busy pediatric dental office Temecula looking for pediatric dentist or Pedo general dentist full time position email @ Fielat@hotmail.com.

Replacement upholstery kits for chairs and stools. Give us a call, we make it simple. Superior Upholstery Company 888-548-7282 superiorupholstery.com.

EFFICIENT EXPERIENCED ENDODONTIST AVAILABLE: AVOID THE HYPE AND HASSLES. WASTING time, produce MORE with practice-building expert on staff. 1EndoInYourOffice1@gmail.com.

New dentist looking to start or buy a practice? Call Wells Fargo Practice Finance at 1-888-937-2321.

ASSOCIATE DENTIST WANTED 2-3 days for busy private practice in San Bernardino. Email resumes to Docjay7@yahoo.com.

Purchasing your new practice, call Bob Affleck @ Citi Practice Finance he will be your biggest advocate 949-939-4550.

Legal Tip You can save up to \$1,700 by forming your corporation at year-end. Attorney Robert W. Olson, Jr., 805.963.1120, www.transdental.com.

Seeking General Dentist as a PARTNER for a Menifee (Next 2 Murrieta) Dental Office. Vietnamese Speaking a Plus. Conact 310-863-5779.

DENTIST NEEDED FULL TIME!! FOR A PRODUCTIVE DENTAL PRACTICE IN THE SOUTH BAY AREA. TOP PAY!! PLEASE CONTACT US ROCIO@ASSUREDENTALCARE.COM.

Chinese-Speaking Dental Assistant Needed for Pedo office in Diamond Bar. Will do front/back office. Email CV to cdsdiamondbar@gmail.com.

Need Associate Van Nuys, part time, 2 yrs experience, great personal skills, can do xbs, Root Canals, email resume: bestfamilydentist@gmail.com.

"Greg helped me through the process of selling my practice so I could retire. He kept me posted each step of the way, was always available, and understood my needs as a person and not just as a seller." Dr. Tran Greg Beamer, 909-542-4891.

Needed Part-time Associate Dentist who is good with molar endo, 2 Saturdays a month. Small office in Brea. Email: sheenabhatiadds@gmail.com.

Registered dental assistant needed for busy private office in Coachella, CA. contact: sunshinedentalgroup06@gmail.com.

Busy office looking for general dentist with 2+ years exp. recent grad welcome contact: sunshinedentalgroup06@gmail.com.

Gentle Experienced Board Certified Oral Surgeon available for your office. Happy to Travel. (949) 892-9088.

lead dental assistant needed. must speak Spanish perfect. text 9546083818 or email Babaketemad07@gmail.com pay \$17-\$25 Santa Ana Ca 92703.

SAN DIEGO PRACTICE SALES Looking to BUY or SELL a practice in San Diego County?? Call the area experts for prompt personal service with integrity. We can also assist you with PRACTICE APPRAISALS, BUY-IN/BUY-OUT TRANSACTIONS, and LEASE NEGOTIATIONS. Call for complimentary consultation. 760-599-7828.

GREATER LOS ANGELES Perio Practice, 5 Ops, Dentrax, Digital, Laser est. over 34 years with long-term staff. HSPPT-Kerri McCullough 949-566-3056-#CA173.

HOW DO I KNOW WHEN TO SELL?

&

Who can I trust
to help me
NAVIGATE ^{THE} SALE?

(855) DDS - 4DDS (855) 337-4337



Darren Hulstine
Broker

Bill Kimball, DDS
Broker

San Luis Obispo Practice

Incredible opportunity to practice in the happiest city in America. Beautiful area to raise a family or retire. Laser periodontist seller does not place dental implants, so there's a huge potential for growth. Beautiful 1,100 square foot office with 4 equipped operatories. The seller is willing to retire or to partner with the right periodontist. Beautiful and well equipped office. Easy parking. Friendly team. Dr will entertain all offers and parties for either half or the whole practice. Half practice valued at \$320,00. Call today for a showing.

Glendale Practice

Prestigious, high-tech general and cosmetic practice. Beautiful office with great exposure. Great space at 1,000 square feet and 4 equipped operatories. Experienced team. Located in busy Glendale near great shopping and entertainment (about a mile from Glendale Galleria). Collections have been consistent for several years. Close to freeway with easy parking. Real Estate available priced separately. Call today for a showing.

Fresno Practice

This well-established practice with seven operatories and is over 2,800 square feet. A very friendly team make this 6-day per week practice a comfortable investment in your future and it's ready to grow! The office has very low overhead, practice is booked out 6 months in advance with almost no openings. Featuring over 3,500 active patients, 70 new patients a month and over 10 years of good will. The real estate is also for sale at a great price of 925k. Why pay rent when you can invest in your self? This could be your dream practice. Please call us for a showing.

New Listing! TURLOCK - Call for details
SAN JOSE - Great location, high visibility, 6 ops
ORCUTT - Established 30 years, great visibility
New Listing! SANTA BARBARA - Call for details
GLENDALE - 5 ops with lots of upside potential
WESTLAKE VILLAGE - Great location
ALHAMBRA - Large practice, call for details
RIDGECREST - Real estate also available
VISTA - 4 ops, nice practice
LA HABRA - Dr. retiring, opportunity to own
PLEASANTON - Call for details
RANCHO CUCAMONGA - Call for details
SAN BERNADINO - Call for details
New Listing! ENCINITAS - Call for details

www.integritypracticesales.com
kirsi@integritypracticesales.com



CA BROKER #01911548
 CA BROKER #01899816

XRAY Chair for sale. EXCELLENT condition only \$500. Call our office and ask for Nadine 619-334-1468.

Endodontists available at your office. Efficient, experienced team. We will bring our own equipment, supplies, microscope and assistant. **NO INVESTMENT** needed on your part. Smartendo1@gmail.com.

Dental office for sale (Ktown). Approx 2k sq ft, 3 ops. Owner moving out of country. Asking 450k. mk7dds@hotmail.com.

Can't find what you're looking for? Call Bruce at The Dental Trader! I've been building a database of dental companies and resources for over three decades. If I can't help you locate it, it probably doesn't exist anymore. I'm here to help. 877 888 4237.

Office Manager needed in Buena Park P/T, flexible hours. Must speak Spanish. Please call (714)994-1456.

DENTAL ASSISTANT NEEDED M-TU-TH. Private 4 OPS office-Walnut. 2-3 years exp., dedicated-reliable. Please, email resume to fahmydds@gmail.com.

Successful dental practice for lease in SanDiego. Contact office for information 619-334-1468. Please ask for Nadine.

PRACTICE FOR SALE PALM SPRINGS GP W/ 10 yrs gdwll in free standing bldg California Practice Sales, Inc. Phone: 714-639-2775.

FT DENTIST WANTED LANCASTER CHILDREN'S CLINIC-Must have minimum 3 years recent experience treating children. Email Resume /CV: dreagilen@gmail.com.

A Private Office in Burbank for Sale, 4 Ops, All Digital, Free Standing Building, Free Parking, Appraised 300K, Call 8182162037.

FOR SALE Steri-Shield Wingers-H Bitewing tabs. Get all 4 boxes for \$50 (MSRP \$45 per box) Email for pictures. gaw1177@gmail.com.

DENTAL PRACTICE FOR SALE SF VALLEY: Must see Shopping Center Opportunity. Call Broker - Practice Sales & Appraisals (818) 999-9595.

Complex Extractions SO CA Offices. Do NOT Refer Out. Increase revenue. Experienced GP will perform ANY extraction category. 6189175805.

DENTAL OFFICE CONTENT FOR SALE. 2 CHAIRS, LIGHTS, CAVITRONS, COMPRESSOR, SUCTION, SURGICAL, ENDO HANDPIECES, AUTOCLAVE, BONDING, LAB EQUIPMENT, INSTRUMENTS. 818-591-0123.

BEVERLY HILLS General Dentistry boutique office w/valet parking. 2 Ops, 1 equipped. OpenDental, Digital, paperless. 2014 GR \$120K. FFS and PPO only. Mario Molina-HSPPT 323-974-4592-#CA215.

NEWPORT BEACH PRACTICE FOR SALE High quality, retiring Dr. does all facets of dentistry including full mouth reconstructions and implants. This practice would be perfect for either a Prosthodontist or General dentist with experience in crown & bridge with attention to occlusion. Grosses \$1.5 million/year on 3 1/2 days/week - 4 days of hygiene - Thomas & Fees Practice Sales (714) 544-4341.

5% off all Osteogenics Cytoplast and buy 5 get 1 free, www.dentalprodx.com.

Want your Dental Trader to follow you?



Just use our Change of Address form at:

www.dentaltrader.com

and provide the address you want it mailed to.

Your home, post office box, anywhere!

The Dental Trader does not sell or share it's mailing list with anyone...your privacy is fully protected.

ASSOC. DENTIST needed sfv area private practice min. 1 year exp. must be gentle, quality oriented, friendly, caring and hard working great atmospher and compensation. email smsinco@gmail.com.

Associate Dentist Needed for N. Orange County/Santa Ana office. Top Pay w/bonus potential!! 3+ years Exp with Valid State of California license. Please contact Rocio@assuredentalcare.com.

Dentist general dentist, part time, minimum 1 year experience, comfortable to treat children and adults. SFV, good compensation. Email ladds96@gmail.com.

Pediatric office looking for experienced back office assistants, PERFECT SPANISH a MUST. Great compensation, friendly environment. Email resume to natalie000@msn.com.

Mission Valley High production/High profit office. Great location in busy shopping center. freeway close. Ken Rubin Practice Sales (619) 299-6161.

Looking for 5yr-Exp good-producing GP for P/T position, private South OC dental office M-F. greatdentistry2015@gmail.com.

Looking to purchase new/lightly used LED Curing Light. Please text/call 323-819-6714 with brand, model, and price. Thank you.

DENTAL OFFICE FOR SALE San Diego City Heights area dental office, 2 operatories. Contact universitydentaloffice@gmail.com for more info.

HENRY SCHEIN®

PROFESSIONAL PRACTICE TRANSITIONS

Contact
one of our
experienced
Transition
Consultants



Dr. Lee Maddox
Lic. #01801165
(949) 675-5578
25 Years in Business



Dr. Thomas Wagner
Lic. #01418359
(916) 812-3255
40 Years in Business



Dr. Dennis Hoover
Lic. #123804
(209) 605-9039
36 Years in Business



Dr. Russell Okihara
License #01886221
(619) 694-7077
33 years in business



Jim Engel
License #01898522
(925) 330-2207
42 Years in Business

PRACTICE SALES • PARTNERSHIPS • MERGERS • VALUATIONS/APPRAISALS • ASSOCIATESHIPS • CONTINUING EDUCATION

SOUTHERN CALIFORNIA

ANAHEIM HILLS – General Dentistry Practice with 4 Operatories has been established for 34 years. The practice utilizes Dentrax and has 6 days of hygiene per week with long-term staff. #CA279 - In Escrow. Kerri McCullough - 949-300-0312.

BALDWIN PARK – This General Dentistry practice features 5 Operatories, 4 Equipped in a 1,500 sq. ft. bright and airy suite. The Gross Receipts were \$276K in 2014 and the office has been established for 10+ years. The Seller is relocating out of state. #CA176- In Escrow. Kerri McCullough - 949-300-0312.

BANNING – This General Dentistry practice features 6 Operatories in a 1,873 sq. ft. suite. The practice utilizes Digital x-rays, EagleSoft, and is fully paperless. There are 8 days of hygiene per week. 2014 Gross Receipts of over \$1.4MM and adjusted net of \$382K. #CA183- Steve Caudill - 951-314-5542.

BEVERLY HILLS – This General dentist has been in practice for 20 years and downsized 2 years ago to a nice boutique office with valet parking for patients. 2 Operatories, 1 equipped. Practice utilizes OpenDental, Digital x-rays, and is paperless. 2014 Gross Receipts \$120K on 3 days/week. FFS and PPO only. Great for downsizing dentist or starting dentist. Huge opportunity for growth. #CA215- Mario Molina - 323-974-4592.

BEVERLY HILLS – General Dentistry Practice with 5 Operatories in a 1,500 sq. ft. suite, located in a prestigious building. Practice utilizes EagleSoft, Digital, CEREC, and most equipment is approximately 7 years old. 4 days hygiene per week, with dedicated, long-term staff. 2014 Gross Receipts were \$1.09MM+. #CA210- Kerri McCullough - 949-300-0312.

CARSON – NEW LISTING – This General Dentistry Practice with 3 Operatories is paperless and features EagleSoft, Digital X-rays, and Pano. All equipment is less than 3 years old. 2014 Gross Receipts of \$143K, room to grow. #CA280- Kerri McCullough - 949-300-0312.

CYPRESS – This General Dentistry practice has been established for 35 years in a 1,676 sq. ft. suite with 5 Operatories. Practice utilizes ComputerAge software and most specialty services are referred out. 7 days of hygiene per week. 2014 Gross Receipts were \$948K with \$426K Adjusted Net Income. #CA257- In Escrow. Kerri McCullough - 949-300-0312.

GREATER LOS ANGELES AREA - Periodontal Practice-This 5 Operatory Perio practice features Dentrax software with Digital X-Rays, Laser, and an Intra-Oral Camera. There is a great referral base, long-time staff and 34 years of Goodwill. #CA173- Kerri McCullough - 949-300-0312.

HUNTINGTON BEACH – General Dentistry Practice with 5 Operatories has been established for 28 years in this beach-side community. Located in a professional building, the practice features Digital x-rays, Pano, Laser, Intra-Oral Camera, and long-term staff with 12 days of hygiene per week. 2014 Gross Receipts of \$1.1M+. #CA263- Kerri McCullough - 949-300-0312.

HUNTINGTON BEACH – NEW LISTING – This General Dentistry Practice with 3 Operatories, 2 Equipped, has 18 years of Goodwill. The practice is near residential, shopping, and freeway. 2014 Gross Receipts of \$396K on 4 days per week. This is a PPO/Fee for Service Practice. #CA277- In Escrow. Kerri McCullough - 949-300-0312.

INLAND EMPIRE – NEW LISTING – Endodontic Practice – This almost paperless 4 Operatory practice features 8 year new equipment, digital x-rays, and Cone Beam CT. The practice has 60+ years of goodwill and is near freeway. 2014 Gross Receipts of \$739K on 4 days/week with low overhead. #CA281- Steve Caudill - 951-314-5542.

INLAND EMPIRE – NEW LISTING - General Dentistry Practice with 7 Ops in 3,000 sq. ft. Practice features Dentrax, digital x-rays, and Pano. 30 years of goodwill. 4½ days of hygiene per week. PPO and 2 HMO plans accepted. #CA283 – Kerri McCullough - 949-300-0312.

INLAND EMPIRE – NEW LISTING - General Dentistry Practice with Four Operatories, Intra-Oral Camera, Digital X-rays, and Pano. Located in a beautiful professional center, this practice's 2014 Gross Receipts were \$534K and Adjusted Net Income of \$196K. Seller is retiring. #CA285 – Think Tran – 949-533-8308.

LOS ANGELES – General Dentistry Practice with 6 Operatories, 5 Equipped, in a free-standing building. Practice has been established for over 50 years, in current location for 29. Utilizes SoftDent with 7 workstations, Schick Digital X-Rays, and an Intra-Oral Camera. Majority of specialty work is referred-room to grow. 2014 Gross Receipts of \$591K. #CA255- Kerri McCullough - 949-300-0312.

LOS ANGELES – Endodontic Practice – This Endo practice with 4 Operatories has been established for over 30 years and utilizes Easy Dental and a Cone Beam. Practice's Gross Receipts for 2014 were \$360K on 21 hours per week. #CA259- Kerri McCullough - 949-300-0312.

NORTHERN CALIFORNIA OFFICE
1.800.519.3458



www.henryscheinppt.com

SOUTHERN CALIFORNIA OFFICE
1.888.685.8100

DENTAL PRACTICE BROKERAGE

Making your transition a reality.



Kerri McCullough
License #01382259
(949) 566-3056
35 Years in Business



Mario Molina
License #01423762
(949) 675-5578
35 Years in Business



Jaci Hardison
License #01927713
(949) 675-5578
26 Years in Business



Steve Caudill
License #00411157
(951) 314-5542
25 years in Business



Tinh Tran
License #01863784
(949) 675-5578
11 Years in Business

More than
75 Years of
Experience!

PRACTICE SALES • PARTNERSHIPS • MERGERS • VALUATIONS/APPRISALS • ASSOCIATESHIPS • CONTINUING EDUCATION

NORTH ORANGE COUNTY - General Dentistry Practice with 7 Ops, 6 Equipped in a 2,700 sq. ft. suite. GR of \$601K with \$244K Adj. Net on a 3 day work week utilizing EagleSoft, Intra-Oral Camera, Schick Digital X-rays, and Pano. #CA248- Kerri McCullough - 949-300-0312.

NORTH ORANGE COUNTY - This General Dentistry practice with 4 Operatories features a beautiful design in a great location near freeway and shopping. Practice features **SOLD** PracticeWorks software with 8 newer workstations, an intra-oral camera, and digital x-rays. Practice has been established for 35 years in this family community. The Gross Receipts were \$360K in 2014. Seller is moving. #CA234- Jaci Hardison - 714-318-4911.

ORANGE - General Dentistry practice with four Operatories, three equipped in 1,600 sq. ft. in a professional building close to Old Town, shopping, and freeways. Practice has been established in Orange for 56 years and features PatientBase software, Digital x-rays, and an Intra-Oral Camera. Practice's Gross Receipts in 2014 were over \$429K. #CA256- Tinh Tran - 949-533-8308.

PALM DESERT - Prosth/Implant Practice with 6 Operatories, 5 Equipped with Dentrux software and 9 workstations, Digital X-rays, Pano, and Intra-Oral Camera. 20 years of Goodwill in this beautiful desert community. 2014 Gross Receipts of \$805K with \$386K Adjusted Net. Practice takes a few PPOs but most patients are Fee for Service. #CA242- Tinh Tran - 949-533-8308.

PALM DESERT - This five-operator General Dentistry practice has been established in Palm Desert for 32 years and is located in a free-standing building. This retiring dentist sees 18 new patients per month and has 6 days of hygiene per week with 2014 Gross Receipts of \$842K and \$339K Adjusted Net. #CA245- Kerri McCullough - 949-300-0312.

PASADENA AREA - NEW LISTING - General Dentistry practice with 3 Operatories, Dentrux, Dexis Digital X-rays, and a CEREC. The practice has been established for 50+ years. #CA283- Kerri McCullough - 949-300-0312.

PICO RIVERA - This General Dentistry practice with 6 Operatories has been established since 1960. Practice utilizes DentiSoft software, an Intra-Oral Camera, and a Pano. Practice has 4½ days of Hygiene per week and 2014 Gross Receipts were \$690K. #CA258- Tinh Tran - 949-533-8308.

SOUTH ORANGE COUNTY - Pediatric Dentistry - This Pedo practice has 4 Operatories, and 1 year new equipment and features a beautiful, modern design, OpenDental, Digital X-Rays, and Pano. 2014 Gross Receipts were \$236K on a 4 day work week with room to grow. #CA222- Tinh Tran - 949-533-8308.

SOUTH PASADENA - This General Dentistry Practice with four operatories, three equipped, is in a 1,150 sq. ft. suite. This is a paperless, digital practice utilizing Dentrux, an Intra-Oral Camera, and a Laser. 37+ years of goodwill with loyal, long-term staff and 4 days of hygiene per week. 2014 Gross Receipts of \$856K with \$271K Adjusted Net. #CA244- Tinh Tran - 949-533-8308.

UPLAND - General Dentistry Practice with 4 Operatories, 3 Equipped, 1 Plumbed, has been established for 25+ years. Practice is located in a Professional Building and features Open Dental, Digital X-Rays, and Intra-Oral Camera. Most equipment is approximately 4-6 years old and most specialty work is referred out. #CA254- Kerri McCullough - 949-300-0312.

VICTORVILLE - General Dentistry practice with 3 Operatories plus 3 plumbed for expansion is located in a 2,150 sq. ft. suite. Practice utilizes SoftDent software with 2014 Gross Receipts of \$273K. Practice has been established for over 34 years. #CA149- Kerri McCullough - 949-300-0312.

WEST HOLLYWOOD - PRICE REDUCED-This General Dentistry practice with 4 Operatories is located in a Professional Building with 9 years of goodwill. Practice utilizes an Intra-Oral Camera, Digital x-rays, and a Laser. The average age of the equipment is 5 years old. 2014 Gross Receipts of \$571K with \$221K Adjusted Net Income. #CA212- Kerri McCullough - 949-300-0312.

WEST LOS ANGELES - General Dentistry practice with 4 Operatories is located in a 1,500 sq. ft., newly built-out suite in a desirable high-rise on LA's west side. Retiring doctor has practiced in the area for over 50 years. This is a strictly Fee for Service practice utilizing Easy Dental, Digital x-rays, and an Intra-Oral Camera. Most specialty work is referred out. In 2014, the Gross Receipts were \$651K. #CA226- In Escrow. Kerri McCullough - 949-300-0312.

WHITTIER - NEW LISTING - This General Dentistry practice has been established for over 50 years in a professional building on a main street. 4 Operatories, 3 equipped. Practice utilizes Dentrux and Dexis Digital X-rays. The majority of all specialty work is referred out. 2014 Gross Receipts of \$217K - room for growth. PPO/FFS office with favorable rent. #CA276- Kerri McCullough - 949-300-0312.

SAN DIEGO

CHULA VISTA - This General Dentistry practice was established 50 years ago, and the seller acquired it 35 years ago. The practice features 4 Operatories, has 3½ days of hygiene, and Dentrux Software. \$493K 2013 Gross Receipts, seller is retiring. #CA109- Russ Okihara - 619-694-7077.

NORTHERN CALIFORNIA OFFICE
1.800.519.3458



www.henryscheinppt.com

SOUTHERN CALIFORNIA OFFICE
1.888.685.8100

HENRY SCHEIN®

PROFESSIONAL PRACTICE TRANSITIONS

DENTAL PRACTICE BROKERAGE

Making your transition a reality.

PRACTICE SALES • PARTNERSHIPS • MERGERS • VALUATIONS/APPRISALS • ASSOCIATESHIPS • CONTINUING EDUCATION

COLLEGE AREA, SAN DIEGO – This is an excellent opportunity in a bustling part of town. This General Practice is a very busy, 6 Operator Practice with room for expansion to 9 Operatories and is ready for the next dentist seeking to find an exquisite office space with an excellent floor plan. The stand-alone building has great exposure and is in a prime location. This is a PPO practice featuring Dentrrix, and Digital X-Rays. The 2014 Gross Receipts were \$1.7MM. Seller is relocating. #CA231- Russ Okihara - 619-694-7077.

DOWNTOWN SAN DIEGO – Leasehold sale: This modern and chic downtown office is in a prime location with excellent foot-traffic and exposure in a business/tourist area. Office features 3 Operatories, with room for expansion. Location is prime for a dentist looking to relocate or to build a practice in a very busy part of Downtown San Diego. #CA232- Russell Okihara - 619-694-7077.

LA JOLLA – NEW LISTING – Quality-driven General Practice with three Operatories. This is a Fee for Service and Delta Premier Practice with a part-time Hygienist. 2014 Gross Revenue of \$559K, Dentist is retiring. #CA278 - Russell Okihara - 619-694-7077.

NORTH COUNTY COASTAL – This General Dentistry is a Fee for Service/PPO Practice with 3 Operatories featuring Dentrrix, and Digital X-Rays. Practice is located in a highly desirable and convenient location. The owner is relocating. 2014 Gross Receipts of \$530K with \$228K Adj. Net. #CA253- Russ Okihara - 619-694-7077.

NORTH COUNTY INLAND – NEW LISTING – Highly-regarded General Dental Practice. FFS/PPO. 6 Operatories located in a beautiful, free-standing building with ample parking. Opportunity for property ownership. #CA271- Russ Okihara - 619-694-7077..

SAN DIEGO – This retiring General Dentist is in a convenient, highly-desirable area of San Diego. The practice features 3 Operatories, with the dentist utilizing 2 Operatories. This is a small, quality Fee for Service practice utilizing PracticeWorks. This will be an ideal starter practice or additional boutique location. #CA161 - In Escrow. Russ Okihara - 619-694-7077.

SANTEE – This General Dentistry practice is a PPO/Fee for Service office with 6 Operatories and is located in a shopping center with great retail anchors. The practice features Dentrrix software and Digital x-Rays. \$780K Gross Receipts in 2014. High-volume practice with 7 days of hygiene per week, and long-term staff. The Dentist is retiring. #CA228 - In Escrow. Russ Okihara- 619-694-7077.

SOUTH BAY AREA, SAN DIEGO – **PRICE REDUCED** - General Dentistry practice with 3 Operatories and 4 days of hygiene per week is available in the South Bay area of San Diego. The practice is located in a well-visited retail center with great visibility and utilizes Dentrrix and Digital Pano. This is a PPO and Fee for Service practice with 2014 Gross Receipts of \$526K. #CA206- Russ Okihara - 619-694-7077.

Upcoming Listing: Escondido, 4 Ops, 3 Chairs, Central Escondido. Doctor is retiring. Excellent opportunity to merge or grow. Looking for a quick sale. For more information, please contact Russ Okihara – 619-694-7077.

OUTSIDE OF CALIFORNIA

MAUI, HAWAII – General Dentistry practice with Gross Receipts of \$636K. Office has 4 Operatories in a 1,198 sq. ft. suite and features Digital Pano, Laser, Intra-Oral camera, Fiber Optics, and 2½ days of hygiene. The owner is retiring. Don't miss the opportunity to live and work in paradise. #20101- Russ Okihara - 619-694-7077.

Upcoming Listings: Maui, Hawaii and Oahu, Hawaii.

NORTHERN CALIFORNIA

CASTRO VALLEY - General Dentistry - Practice & Building, 1,800 sq. ft. 3 equipped Ops, 1 add'l plumbed. 2014 GR of \$373K on 4 days/week. #CA251 Jim Engel - 925-330-2207.

FOLSOM – General Dentistry - 2,420 sq. ft. w/5 Ops, Schick Digital X-rays, non-digital Pano, Softdent. #CA235-Thomas Wagner - 916-812-3255.

FOLSOM – **FACILITY ONLY** - 1,200 sq. ft. with 3 Ops, digital x-rays & pano. #CA209-Thomas Wagner - 916-812-3255.

GREATER PITTSBURG AREA – **PRICE REDUCED** by \$122,000 - General Practice + Bldg. 7 Ops. 2,324 Sq. Ft. 2012 GR \$885K #CA108 Thomas Wagner - 916-812-3255.

GREATER ROSEVILLE/ROCKLIN/LOOMIS – General Practice. 1,500 sq. ft., 5 Ops (4 equipped), Dexis, Dentrrix. #CA239 - Thomas Wagner - 916-812-3255.

GREATER SACRAMENTO – General Dentistry - 7 Ops, 3,079 Sq. Ft. (Shared w/2nd DDS – Separate Practices), 2013 GR \$974K. #CA140- Thomas Wagner - 916-812-3255.

GREATER SACRAMENTO – General Dentistry - 2,100 sq. ft. w/6 Ops, Dentrrix. Combined 2013 GR of \$1.1MM. #CA237 - Thomas Wagner - 916-812-3255.

GREATER SAN JOSE AREA – Perio Practice. Fiscal-year GR \$1.3MM. 5 Ops, 2 add'l plumbed, in same loc. 28 years. #CA219-Dennis Hoover - 209-605-9039.

MARIN COUNTY – Mill Valley 1,260 sq. ft. 3 Ops, 1 add'l plumbed. Dentrrix, Digital, Intra-Oral. #CA224-Jim Engel - 925-330-2207.

MARIN COUNTY – General Dentistry- 3 Op practice. 2014 GR\$315K. Paperless charts, Schick Digital Sensors, Eaglesoft software. Owner retiring. #CA286-Jim Engel - 925-330-2207.

MILLBRAE – General Dentistry- 1,500 Sq. Ft. leased office with 5 Ops, 1 additional plumbed, state-of-the-art equipment. 2014 GR \$670K. #CA262-Jim Engel - 925-330-2207.

NORTH COAST - Endo Practice. 6 Ops, 5 plumbed 3,300 sq. ft. Digital, Microscopes, EndoVision. #CA214-Jim Engel - 925-330-2207.

NORTH EAST OF SACRAMENTO – 2,500 sq. ft., 7 Ops with intra-oral, digital x-ray, and Eaglesoft software. 2014 GR \$1.5M. #CA268-Thomas Wagner - 916-812-3255.

NORTHERN CALIFORNIA OFFICE
1.800.519.3458



www.henryscheinppt.com

SOUTHERN CALIFORNIA OFFICE
1.888.685.8100

HENRY SCHEIN®

PROFESSIONAL PRACTICE TRANSITIONS

DENTAL PRACTICE BROKERAGE

Making your transition a reality.

PRACTICE SALES • PARTNERSHIPS • MERGERS • VALUATIONS/APPRISALS • ASSOCIATESHIPS • CONTINUING EDUCATION

NORTH OF SACRAMENTO – 1,750 sq. ft. office w/4 Ops. Intra-Oral, Digital X-ray, Pano, Laser, CAD-CAM, & Dentrax software. 2014 GR of \$1M. #CA260-Thomas Wagner - 916-812-3255.

NORTH OF SACRAMENTO – 1,324 sq. ft. office w/4 Ops, Dentrax software, Pano.. Owner worked 39 weeks in 2014. #CA267-Thomas Wagner - 916-812-3255.

NORTHERN CALIFORNIA – Perio Practice, Partnership Position. 6 Ops, 1,500 Sq. Ft. Dentrax. Owner Financing Available. #CA168-Thomas Wagner - 916-812-3255.

NORTHERN CALIFORNIA – Endo Practice. 3 Ops, 1 Plumbed, 1,200 Sq. Ft. 2 Microscopes, Digital. 2013 GR \$319K. #CA158-Thomas Wagner - 916-812-3255.

NORTHERN SACRAMENTO – 3 Ops in a leased space with <1,000 sq. ft., PPO practice, 2 days hygiene, digital x-rays & Easy Dental software. #CA266-Thomas Wagner - 916-812-3255.

OROVILLE – General Practice. 1,000 sq. ft., remodeled 2010. Dentrax & Dentrax software, Digital Pan & X-rays, Laser, Intra-Oral. 2014 GR \$512K. #CA287-Dennis Hoover - 209-605-9039.

OROVILLE – General Practice. 3 Ops, mostly new equipment & recently remodeled. Great satellite or startup practice. Owner retiring. #CA288-Dennis Hoover - 209-605-9039.

OAKLAND - General Practice. Piedmont District. 3 Ops in **SOLD** office w/1,600 sq. ft. GR\$453K. #CA217 Jim Engel - 925-330-2207.

PITTSBURG – General Dentistry- 3 year avg. GR of \$236K **SOLD** % overhead. 5 Ops in 1,400 sq. ft. with Pano. #CA133- Jim Engel - 925-330-2207.

PINOLE – Endodontic Practice.- 4 Op Endo office w/Digital X-ray, Microscopes, and PBS Endo software in approx. 1,200 sq. ft. 2014 GR \$672K. #CA284- Jim Engel - 925-330-2207.

PLEASANTON – Facility Only, Former Endo Ofc, Good GP Startup. 2 Ops, 1 Plumbed & Partially Eq. 975 Sq. Ft. #CA195-Jim Engel - 925-330-2207.

SACRAMENTO – 7 equip Ops in 2,400 sq. ft., 1 add'l Op plumbed. Pano, Softdent, Digital. 2014 GR \$626K+. #CA250-Thomas Wagner - 916-812-3255.

SACRAMENTO – Practice and Condominium. 1,300 sq. ft. office, 4 Ops. Eaglesoft software. 2014 GR \$650K. #CA261-Thomas Wagner - 916-812-3255.

SACRAMENTO – 1,684 sq. ft., 6 equip. stations in bay, 2 add'l plumbed. 2014 GR \$590K. #CA269-Thomas Wagner - 916-812-3255.

SACRAMENTO – PPO practice, 8 Ops in 3,700 sq. ft. **SOLD** retiring. #CA238-Thomas Wagner - 916-812-3255.

SAN FRANCISCO – General Dentistry. 3 Ops, 2 Equipped, 780 Sq. Ft. 2013 GR \$854K. #CA191-Dennis Hoover - 209-605-9039.

SAN FRANCISCO – Periodontal Practice & Condo Unit. 1,160 sq. ft. w/4 Op, 2014 GR \$714K w/\$363K Adj. Net. #CA274-Dennis Hoover - 209-605-9039.

SANTA MARIA – 4 Ops, Easy Dental, Dexis, and Intra-**SOLD** cameras. 2013 GR of \$523K in 180' Dr. days. #CA166- Jim Engel - 925-330-2207.

SANTA ROSA – General Dentistry & Building. 3 Ops. 2013 GR \$542K w/Adj. Net \$182K. #CA200-Dennis Hoover - 209-605-9039.

SOLONO COUNTY – General Practice: 1,350 sq. ft., 4 Ops, Intra-Oral, Digital, Pano, and Dentrax **SOLD** 2014 GR of \$869K on 30 hour/week. #CA246-Thomas Wagner - 916-812-3255.

SONOMA – Stand-alone 2,000 sq. ft. office w/4 Ops. Digital X-rays, Lasers, CAD/CAM. 2014 GR \$675K on 3 day/week. #CA270- Jim Engel - 925-330-2207.

SOUTHERN SACRAMENTO COUNTY – General Practice: Condo office with 1,380 **SOLD** sq. ft. & 4 Ops, Intra-Oral, Dexis, Pano, Laser, Easy Dental. 2014 GR were \$581K #CA249 -Thomas Wagner - 916-812-3255.

WALNUT CREEK – Prosth Practice. 3 Ops, Full Lab. **SOLD** GR \$399K w/Adj. Net \$143K. #CAM540- Jim Engel - 925-330-2207.

CENTRAL CALIFORNIA

CENTRAL COAST – CENTRAL COAST –General Practice in the Central Coast area. 31 years of goodwill. 6 Ops, 8 days of hyg/week. 2013 GR of \$2.3MM and Adj. Net of \$840K. Dentrax, Digital, Paperless, Intra-Oral Camera, Laser. #CA208-Kerri McCullough - 949-300-0312.

FRESNO - General Dentistry Partnership. 2013 Partnership GR \$4.7M. Selling Partner 2013 Net Inc \$368K. #CA196-Dennis Hoover - 209-605-9039.

FRESNO – General Practice. 4 Ops, 1,739 Sq. Ft. CEREC, **SOLD** overhead. 2013 GR \$740K+. #CA202-Dennis Hoover - 209-605-9039.

FRESNO – 5 Ops, 4 equipped, 1,400 sq. ft. w/Pano, Dentrax **SOLD** digital. 3 years GR averaging \$409K. Priced to sell. #CA243 - Jim Engel - 925-330-2207.

KINGS COUNTY – *NEW LISTING* - Practice has been est. 50 years in a rural community. 4 Ops, intra-oral camera, and Pano. 2014 GR were \$246K. Great location to relocate or open a 2nd office. #CA265 - Steve Caudill - 951-314-5542.

MADERA - General Dentistry –Building & practice. 6 Ops, 3000 sq. ft., Dentrax software, Dexis software, Pano. 2014 GR \$850K. #CA289-Dennis Hoover - 209-605-9039.

PASO ROBLES – Modern 4 op, 1,998 sq. ft. office with Digital X-ray, Softdent software. 2014 GR \$573K+. #CA275 - Jim Engel - 925-330-2207.

PORTERVILLE – General Dentistry with 6 Ops in a 2,600 sq. ft. suite located in a retail center. 2014 GR of \$555K. 7 year new equipment, intra-oral camera, Pano, PracticeWeb. #CA223-Steve Caudill - 951-314-5542.

TULARE - 2,300 sq. ft. free-standing office w/5 Ops. 2014 GR \$1.7M. 10 days hygiene. Owner moving out of state. #CA273- Dennis Hoover - 209-605-9039.

TUOLUMNE COUNTY - General Practice & Bldg. **SOLD** 2,000 Sq. Ft. 2013 GR \$1MM+ #CA199- Dennis Hoover - 209-605-9039.

NORTHERN CALIFORNIA OFFICE
1.800.519.3458



www.henryscheinppt.com

SOUTHERN CALIFORNIA OFFICE
1.888.685.8100



Cecilia Chen, Attorney

*Super Lawyer 2014
Nominated by Peers*

How might Social Media Impact my Practice Value and Goodwill?

In today's social media hyper connected world, a practice's goodwill is heavily influenced by patient loyalty and relationship. While it's important to maintain high patient satisfaction and being able to reach an audience far greater than the number influenced by traditional advertising, too much connection could impact the practice value negatively. For instance, if the selling doctor is very active and connected with the patients through social media, a buying dentist might believe that many patients would maintain contact with the selling doctor through facebook or twitter, resulting in a much higher attrition rate.

Serving Dental Professionals:

- Practice Sales and Acquisitions
- Lease Review and Negotiation
- Partnership Formation and Buy-Out
- Practice Start-Up and Incorporation
- Associate and Fee Sharing Agreements
- Estate Planning

Testimonial:

Cecilia assisted me in buying my first practice. Not only did she do an excellent job to make sure that my interests and investment is protected, she went out of her way to negotiate 3-months rent abatement for me, which gave me the much needed breathing room during the transition period. I highly recommend Cecilia and thank her for her efforts to me now becoming a proud first time practice owner.

Dmitry Aminov, DMD



LAW OFFICES OF
CECILIA CHEN

Toll Free: 855.850.4111

Email: cecilia@practiceatty.com

www.practiceatty.com

FREE ONLINE CLOUD BACKUP up to 2GB. HIPAA Compliant with full data encryption. See www.ez2000dental.com, then click Products Link, then click Cloud Backup Services, and Download the FREE LINK. Need help? Call 800-273-5033. No charge for our assistance.

**NATIONWIDE DENTAL PRACTICES FOR SALE. BUYERS & SELLERS WANTED. FREE CONSULTATIONS. 100% DENTAL PRACTICE FINANCING. CALL PROMED FINANCIAL 888-277-6633
WWW.PROMED-FINANCIAL.COM.**

Cecilia Chen, Esq always made herself available to answer our questions, many times getting back to us in the middle of the night to make sure everything was addressed. —Rita and Frank Woo, DDS.

Looking for an Endodontist for 1/day a week in our PPO/FFS/HMO practice located in Eastern San Diego County. Please email your resume to ecdental@att.net.

PROTECTING (you and your practice), **PROVIDING** (knowledge, experience and advice) and **PROVING** (to be the best in the Nation). 3 QUALITIES YOUR ATTORNEY SHOULD HAVE. WOOD & DELGADO www.dentalattorneys.com.

Part time GP DR and RDA or DA and TX coordinator/Biller NEEDED in UPLAND fax Resume 909-949-3005.

Why Give Up Your Patients To Other Dentists? Have All Undoable RCTs Done At Your Office. Visit www.socalrootcanal.com.

GP position open MWF Comfortable working with children. OCS, Spanish a plus. partnership/ownership Biz/Building with Pedro Sugarbug888@gmail.com.

Thank you for your patience in helping me and my family select the proper medical coverage! So many options but with your help we finally have the right one! – Todd Brilliant DDS, San Diego. www.TheDoctorsInsuranceBroker.com, jonathan@tdibroker.com or call 800-767-0864.

Experienced GP to perform Implants, Extractions, and RCTs in your SoCA practice. Brings Equipment, Instruments, Materials. Flexible Schedule. Call 618.917.5805.

Wanna save paper? Retired but your dental license is still active and wish to remove yourself from the Dental Trader mailing list? Go to <https://secure40.securewebsession.com/thedentaltrader.com/cancellationsecure.htm> and you will be automatically removed from our current list and all future mailing lists we buy. You'll save a tree too!

Chinese-speaking dental assistant-PT, near Brea/Rowland Heights. Email resume to use8office@gmail.com.

BANNING 6 Ops, recently remodeled, GR of \$1.4M+ in 2014. Room for 4 additional Ops. HSPPT-Steve Caudill 951-314-5542-#CA183.

HYGIENE INSTRUMENTS FOR SALE various cassetts, scalers, basic sets, syringes, sharpening stone, probes, slow speed. \$1,500 OBO Darabantp@yahoo.com.

YOUR NEEDS COME FIRST! At Orange County Business Bank being local allows us to provide you with faster service. We can get things done! Contact Howard Boles 949-379-5704 Equal Housing Lender-The bank makes such loans without regard to race, color, religion, national origin, sex, marital status, age, handicap, familial status, applicant's receipt of income from any public assistance and applicant's exercise, in good faith, or any right under the Consumer Credit Protection Act. Member FDIC.

ADD \$250,000 TO YOUR YEARLY PRODUCTION! Request Our Free Production Building Guide Specifically Formulated For Practice Owners and Associates. profitableGPs@hotmail.com Tel: (310) 699-3441.

Orthodontic assistant or RDA needed with experience for Fast paced high volume office PT or FT Email: office@embrace-ortho.com.

LOOKING TO BUY PRACTICE IN STUDIO CITY. ALL OPTIONS CONSIDERED. PLEASE EMAIL: mydds@outlook.com

DENTAL ASSISTANT needed for office in Costa Mesa. Minimum one-year experience. Must speak Spanish. Email resume to anthonyhungcao@gmail.com for interview.

Schick CDR Elite Size 2 Sensor only. Make an offer. dentalitems4sale@gmail.com.

Immediate FT/PT Opening for GP in Escondido/Vista San Diego Area. Contact Stephanie 9493073492.

****DENTIST** needed in LONG BEACH. Must be a Denti-Cal provider, minimum one-year experience. High pay, bonus. Email resume to anthonyhungcao@gmail.com.

Dentist needed for community health centers in Ontario and Pomona. Submit resume via Fax 909 4285757. Or Email Info@thegrovedental.com.

CONSUMER

ALERT!

The Dental Trader

refuses to do business
with the following companies:

AMERICAN BUSINESS CARD

aka: Bizcard.com

(A CEG Company)

P.O. Box 15190

Scottsdale, AZ 85267

www.americanbusinesscard.com

Ph: 800-555-2234 Fax: 800-500-4506

PROFESSIONAL FINANCING INC.

Alexander Slepak

20371 Irvine Avenue, #100

Newport Beach, CA 92707

www.professionalfinancing.net

doctor@professionalfinancing.net

Ph: 323-272-3543 Fax: 480-948-0082

This notice is based on the advertisers' contractual lack of performance and/or legal action/court judgments.

If you have had a problem with these or any other Dental Trader advertiser, please send your formal complaint to:

The Dental Trader

Attn: Complaints

Post Office Box 2631

Capistrano Beach, CA 92624

Fax: 949-498-1198

Email: tradestaff@cox.net

Be sure to include any relevant documentation concerning your complaint

Compare commissions.... then put my 22 years of experience to work for you



I started DDS Xpress with a simple mission, to provide dentists an alternative to the traditional practice brokerage. A place free of the constraints, high broker fees, limited service and long, restrictive contracts. I created DDS Xpress to be a full service dental practice sales boutique that is specifically designed for busy dental professionals. From start-up, to retirement and everything in between, we provide you personalized service to meet your needs. Whether you are looking to purchase, expand your practice, or considering retirement, thinking about selling your practice or seeking an investment property, I will provide exactly what you seek without any headaches and at a commission rate you will love. Give me a call.

CURRENT OPPORTUNITIES AVAILABLE FOR SALE:

Los Angeles County area Six operatory facility located in free standing building on major thoroughfare providing excellent exposure. Practice collecting approx. \$650,000 in revenues. Building is for sale. A Must See Opportunity. Practice Video available for viewing convenience. Call for full details.

Inland Empire area Retiring doctor offering over 38 Years of Goodwill. Practice offers 4 operatories in Group Solo practice, Condo suite for sale. This group solo practice shares common waiting room with Podiatrist and Medical Doctor exposing the practice to new patients. There are 2 Hygiene Days per week and Seller works 3 Days per week collecting approx. \$400,000 in revenues. Practice Video available for viewing convenience. Call for full details.

Malibu Turn-Key Opportunity Store front location offering 4 operatories, walking distance to beach and ocean breeze included. Practice Video available for viewing convenience. Call for full details.

Office: 951.309.3196 • Cell: 951.437.0419
Fax: 800.532.0739

Email: tinaochoa@ddsexpressrealty.com

(Southwest Riverside County Association of Realtors)

www.ddsexpressrealty.com



Complete Dental Office \$23,029

Normal Install in CA

A fully equipped Dental Office with 2 Dental Operatories, 2 Dentists Stools, 2 Assistants Stools, Digital Intra Oral X - Ray Machine, Dental Vacuum System, Dental Oil Less Air Compressor with Drying System, Autoclave Sterilizer and a Complete Utility Room Control System.

Dental Office Design Available !!!



(800) 423 -5657

Dansereau Dental

WWW.DHPDENTAL.COM

1581 Commerce Street, Corona CA 92880

**Simple Low
Interest
Financing**

OAC

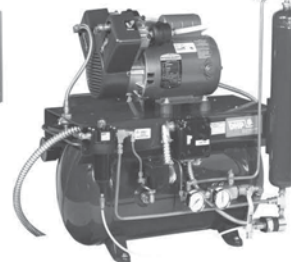

**All New * Fully Warranted
Factory Installed * Made in USA**

Normal Installation within 2 hours of Factory*

ORTHO RDA WANTED Fun Christian based Ortho office seeking Ortho RDA in Redlands Ca. Send resume to braces@paulsonortho.com.

Traveling Orthodontist Orthodontist available locum tenens and part-time, perfect for vacation or adding ortho to your general practice. travelorthodontist@hotmail.com.

Spanish speaking dentist needed for Tuesday, Wednesday and Saturday Pomona area. Please fax resume to 909-992-3380.

3 NSK TiMax X600L Optical Highspeed with 2 6 pin LED coupler. Make offer. dentalitems4sale@gmail.com.

Dental office in Westlake Village is looking for a dental assistant. Send resume georgiandental@gmail.com, fax 818-991-4665 Great communication skills required.

Looking for a traveling ENDO, ORTHO and OS. once a month grow to more days. Email onlytops@gmail.com with salary req.

experienced and friendly dentist looking for a part time position with an option to buy out 8183264684.

Dental Assistant P/T needed in Burbank Please email CVT to dentistsassociates@gmail.com.

CORONA OFFICE FOR SALE Busy Retail Center location. 4 equipped rooms & plumbed for 6 more! Recently renovated including ortho bay. Sale includes existing patient base. Great opportunity. Inquiries to ddscorona@yahoo.com.

TORRANCE dental office sale. Asking \$350k. Great area. 1k sqft, 2 ops equipped, 1 plumbed. All digital office. mk7dds@hotmail.com.

CAVITRON SCALER TIPS OLDER, BUT FUNCTIONAL 11 USED, 3 BRAND NEW IN BOX. \$1200 EMAIL OR CALL/TEXT DOCJTY@GMAIL.COM, 310-292-7812.

Antelope Valley HMO practice collects \$1.1 million with \$12,500/mo in capitation. Nets over \$450,000/year. 7 ops. No Denti-Cal. Asking \$828,000. Kurt Skarin 805-777-7707.

Dentist wanted in El Centro (imperial valley). \$800 per day. US trained only. Full/part time position. (310)733-8508 Aakhorsand@gmail.com.

Anaheim private office looking for an experienced dentist for Thursdays. Please email your CV to tdds75@yahoo.com for immediate consideration.

ENDO instruments New and like new many files, hand condensers/spreaders Will sell all very cheaply. (323) 851-6622.

DENTAL PRACTICES WANTED in Southern & Northern California Gross \$950K to \$1.1 Mil. PPO. Associate run is ideal. Sellers call Loc Pham, Broker at LCF Financial, Inc. BRE #01875780. (714) 550-7494 or practice@lcfinc.com | LCFPracticeSales.com.

Is it the right time to list your practice? Find out from Steve Caudill, Henry Schein PPT 951- 314-5542.

DENTIST WANTED! in Cerritos. 3 DAYS FT. Great OFFICE and PAY. Must have DEA, license liability and US trained. jes.innovative@gmail.com.

PROACTIVE *SEO* SOLUTIONS

At Proactive SEO Solutions, we offer a slew of online marketing services, including SEO, PPC, Web Design, Daily Deals, Social Media Management and Reputation Management.

**Are you a new or existing practice?
Need more patients?
Falling behind on marketing?**



**Call (310) 994-1136
For a Free Consultation**
www.proactiveseosolutions.com

Free Consultation

PROACTIVE **SEO** *SOLUTIONS*

LET US BUILD YOUR ONLINE FOUNDATION

Our Services Include

- Responsive Website Design
- SEO (Search Engine Optimization)
- PPC (Pay Per Click)
- Social Media Management
- Reputation Management
- Video Production
- Phone Tracking
- +more

Call (310) 994-1136



The Name You Know
The Reputation You Trust

Greg Beamer, Dental Broker

Experience in Finance and Brokerage since 1976

- 22 + YEARS EXPERIENCE
- FULL-SERVICE BROKERAGE
- PROVIDES BUYER OR SELLER REPRESENTATION
- APPRAISALS AND EVALUATIONS
- PRACTICE TRANSITIONS
- FINANCIAL ASSISTANCE

New Listings

SOUTH RIVERSIDE COUNTY ESTABLISHED PRACTICE

80%-20% Insurance and cash. Shopping center with great signage. Strong buyer's net. Perfect opportunity for two dentists. Steady collections over \$1M for the last three years. (6) treatment rooms. 25-35 patients a day and 60-70 new patients/mo.

ORANGE COUNTY PRACTICE

I have just listed a premier location priced under the cost of the build-out. Collecting \$250K a year on two days a week. If you have thought about creating a professional office in Orange County, just call me - I have it! And the patient base stays with the sale!

RANCHO CUCAMONGA PRACTICE

(3) treatment rooms and (1) plumbed not equipped in a 1,600 sq. ft. suite. 2nd story location in a professional multi-building complex on a busy street - heavy daily traffic. Rent is very reasonable and all inclusive at \$2,900/mo. Sellers have a second practice in Hesperia. Established in August of 2013, the practice is open 2.5 days a week and has approximately 600 active charts. You will not believe the price!

FULLERTON LOCATION

Great area near CSUF on Chapman Avenue. (4) treatment rooms and (2) plumbed not equipped treatment rooms in a 1,400 sq. ft. suite. 30 year history as a dental office. Rent is very reasonable at \$3,300/month. Priced to sell!

HUNTINGTON BEACH LOCATION

(3) treatment rooms, (2) consultation rooms, (1) recovery room, and plumbed for (2) additional treatment rooms in a 1,800 sq. ft. suite located in a two story medical/professional office building off a busy street. Currently an Oral Surgery Practice. The location could be a successful GP or Specialty Practice. The landlord is prepared to draft a new fair-market value lease. Selling as a Leasehold Improvements and Equipment Only. Motivated Seller-Priced to Sell!

PASADENA PRACTICE

Just listed - strong general practice - 2,200 sq. ft. suite in a multi-story medical dental building. Convenient to the 110, 210 and 134 freeways, this 19 year practice is projecting \$1MM plus for 2015. (6) treatment rooms and (1) plumbed not equipped for expansion. Solid patient base and a strong buyer's net.

(909) 542-4891 phone
(866) 890-1033 fax
info@gregbeamer.com
www.gregbeamer.com

Northridge Medical/Dental spaces for lease. Recently remodeled building at 9241 Reseda Blvd. 818 709-8645 or drgropp@aol.com.

DA FOR QUALITY SOUTH TORRANCE GP PRIVATE OFFICE PART-TIME. FAX RESUME, HANDWRITTEN COVER LETTER TO 310-326-5499. WILL TRAIN QUALIFIED INDIVIDUAL.

PRACTICE FOR SALE SAN LUIS OBISPO COUNTY Beautiful off. w/ 6 ops; Net \$323K California Practice Sales, Inc. Phone: 714-639-2775.

DANSEREAU CHAIR FULLY FUNCTIONAL. YELLOW FRAME WITH VINYL/FABRIC UPHOLSTERY FOR PICKUP IN TORRANCE \$300. EMAIL DOCJTY@GMAIL.COM, 310-292-7812 CALL/TEXT.

ORAL SURGEON SPECIALIST South Bay dental office looking for Oral/Maxillofacial Surgeon. Please email resume to ufdhire@yahoo.com.

Endodontists available at your office. We will bring our equipment, supplies, microscope, assistant. NO INVESTMENT needed on your part. smartendo1@gmail.com.

ORTHO chula vista turnkey office condo for sale or lease. 4 chair open bay. For details/photos call 619 298-1775.

We have 3 peri-apical dental x-ray for sale we no longer use please call 209-322-3429.

ASI self contained for sale \$4,200 we prefer selling both unit. They are in working condition. call 209-322-3429.

Memory foam ultraleather, massage systems. Are you relaxed yet? Superior Upholstery Company 888-548-7282 superiorupholstery.com.

Space for Sublease BH/LA area. Existing Perio office to share space. New office and equipment, fully staffed. 310-487-2101, drr@perioartist.com.

Endodontists available at your office. We'll bring our equipment, supplies, microscopic, assistant. NO INVESTMENT needed on your part. smartendo1@gmail.com.

"I needed Greg to provide an appraisal of my office on short notice – he not only beat the deadline, but his appraisal was accurate and well-presented." Dr. Irvani Greg Beamer, Dental Broker 909-542-4891.

Looking for part time General Dentist to work in beautiful PPO office in downtown Orange. No Endo skill necessary. Loriabagai@sbcglobal.net.

need experienced friendly office manager for busy office in coachella. email sunshinedentalgroup06@gmail.com.

Front office receptionist Treatment Coordinator positions in Beverly Hills available. Experience a must. Submit resume to: lkramer66@ymail.com. Must know Dentrrix.

All County was great throughout my entire const. Project. Couldn't have been any smoother. Dr. D Ghorab. 714-240-7179.

FOR SALE Sultan Healthcare Upgrade Disposable Prophylaxis Angles. Pkgs of 100. For sale \$29. (MSRP \$60) Email for pictures. gaw1177@gmail.com.

***"The Dental Trader works fast!
I received a call this morning even
though I placed the ad online only last
night. The ad took minutes to place,
posted instantly to The Dental Trader
website, generated immediate response
and cost me nothing! That's what I call a
good deal."***



**Dr. Phil
Murrieta, CA**

Looking for dental assistant in Santa Ana part-full time. please email granddentalgroup@gmail.com.

RECENT GRADUATE Bargain content of Dental office for sale. 2 chair units, xray suction compressor, autoclave, much more \$19000. 818-591-0123.

ENDODONTIST NEEDED! For growing Dental company with Multiple offices. We offer very Competitive Compensation Programs!! Please contact us rocio@assuredentalcare.com.

DENTAL PRACTICE FOR SALE PALMDALE: Retiree. 20+ years of Goodwill. HMO income of \$5K/mo. Priced Right. Call Broker - Practice Sales & Appraisals (818) 999-9595.

ADEC PORTABLE Dental unit. H.S. & Low speed, vacuum with portable compressor. Portable repair case. \$1500. (Used once) 310-642-6575.

WE ARE LOOKING for a Dentist to join our team two to three days a week as dentist is preparing for retirement. We look forward to hearing from you. Please contact Georde at 562-982-1552.

My focus is on exceptional service. My clients have placed a high volume of trust in my ability to assist them with the sales process. My efforts are dedicated to creating a simplified/efficient transition experience. Greg Beamer 909-542-4891.

Dental Instruments New or like new Rubber Dam Punches (6 -all Hu-Friedy) Clamp Removers (12) Cotton pliers (5)(323) 851-6622.

NAVIGATING THE DENTAL TRANSITION MINEFIELD 2015

7 AGD HOURS

WHETHER YOU OWN OR PLAN TO OWN A DENTAL PRACTICE, THIS SEMINAR IS FOR YOU!

This will be an in depth look at the many issues you face when selling or purchasing a dental practice, entering in to a partnership buy-in or becoming an associate with an option to buy the dental practice in the future.



Patrick J. Wood
DENTAL ATTORNEY



Art Wiederman
DENTAL CPA



Kathleen Johnson
MANAGEMENT CONSULTANT

Three of the leading experts in dental practice transitions will point out the many issues you will face when attempting to sell or acquire a dental practice. Areas of discussion will include:

- Evaluating books and records
 - Analyzing the dental software and charts
 - Lease issues which can destroy your investment
 - Pitfalls in the purchase agreement
 - Tax ramifications of sale or purchase
 - Continuing to practice dentistry after a sale
 - Restrictive covenants and covenants not to compete
 - Financing issues
- and many other topics...

October 30, 2015 | 8:30 registration • 9:00–3:30pm

GLIDEWELL LABORATORIES

18551 Von Karmen Avenue • Irvine, CA 92612

SPONSORED BY:

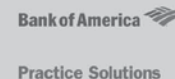

Name: _____ **Phone:** _____

Billing Zip Code: _____ **Lic#:** _____

Email: _____

If paying by a Credit Card please fax registration to: 714.259.0406

Please circle the card you'll be using: Visa / Mastercard / Amex

Card Number: _____ Exp: _____ 3 or 4 Digit CVC Code: _____

Card Holder Name: _____ Card Holder Signature: _____

Register online: <http://www.w-acpa.com/seminars.html>

If paying by check, please make payable to:

Wiederman & Associates, mail to: Wiederman & Associates, 1415 Warner Ave., Suite C, Tustin, CA 92780, 714-259-0505

SEATING IS LIMITED

Before October 10, 2015 # Attending _____ x \$99.00 = _____

After October 10, 2015 # Attending _____ x \$125.00 = _____

Spouse \$59.00 = _____

TOTAL = \$ _____

PRACTICE FOR SALE SAN JUAN CAPISTRANO GP w/ 4 eq ops, 3 plmbd not eq California Practice Sales, Inc. Phone: 714-639-2775.

ABO Board certified Orthodontist w/ 2+ yrs. experience looking for part-time work in established Orthodontic clinic. Contact OrthoProspect@gmail.com.

Dental Instruments New or like new condensers/carvers for composites and amalgams. Explorers, perio probes, 5 only-perio scalers (323) 851-6622.

SOUTHWEST RIVERSIDE COUNTY (5) op comput G.P. for sale. (4) ops eq't'd/(1) additional plumbed. Located in a smaller prof. building in a condo which is also available. Cash/PPO pts. No HMO and no Denti-Cal. (14+) years of Goodwill. 2015 Projected Gross Collections of \$400K+. Seller is giving up private practice for a Govt. position. D&M Practice Sales 818.591.1401.

\$5495 New Dental Operator, Includes Free Dentists Stool, Delivery and Install. Made in USA 10 Year Warranty. Call (800) 423 - 5657 for more details.

DENTAL PRACTICE FOR SALE ANAHEIM: Over 19 years of Goodwill. Busy Shopping Center. Call Broker - Practice Sales & Appraisals (818) 999-9595.

Complete Sensor and Practice Management System. Package includes everything you need to take x-rays and collect your money from insurance and patients. Call 1(800)397-6046.

Roving ENDODONTIST Needed SAN DIEGO County - multiple offices. Compensation 50% of fee. Call 619-342-6070.

FOR SALE Pedo Pediatric Typodont. Dental Study Model. Used for dental school. \$80. Email for pictures. gaw1177@gmail.com.

Purchasing your first practice? Bob Affleck at Citi Practice Finance he will guide you through the process 949-939-4550.

Oral Surgeon for your office! Don't refer out!!! Enjoy an added income stream! Will come in to do wisdom teeth extractions, implant placement, IV sedation. Will bring my assistant and instruments--no investment needed on your part. Prefer Inland Empire, Orange County, San Diego County. Please call 413-505-9324.

Is it the right time to list your practice? Find out from Dr. Russell Okihara, Henry Schein PPT 619-694-7077.

Pedodontist and GP needed for a pediatric community clinic in Costa Mesa. Experience preferred. Please send CV to dentalcareers@shareourselves.org.

DENTAL PRACTICES WANTED in Culver City, Torrance, San Fernando Valley Turnkey practice. Existing charts. Good visibility. Real estate is a plus. Sellers call Loc Pham, Broker at LCF Financial, Inc. BRE #01875780. (714) 550-7494 or practice@lcfinc.com | LCFPracticeSales.com.

CLARIS i4D IntraOral Camera. The ultimate everyday IntraOral camera. Sony CCD sensor. Clearer Image. Expertly engineered. 2 year warranty. Brand new. List: \$3,995. Sale: \$2,750. Call 310-204-6134 and ask for Mark.

Financing for your practice and so much more. We can help you reach your practice goals. Call Wells Fargo Practice Finance at 1-888-937-2321 or visit us at wells Fargo.com/dentaltrader.

PRACTICE FOR SALE RANCHO MIRAGE. Estab GP in Busy, Upscale retail center. 4 Ops in 1500 sq.ft. LOTS referred Out!! SDPS: 769-599-7828.

LONG BEACH PRACTICE FOR SALE Gorgeous, modern 5 operator private practice for sale - 78 year old owner retiring - 4 1/2 days of hygiene - digital x-rays - Grosses almost \$1.1 million/year - Thomas & Fees Practice Sales (714) 544-4341.

Encino fee for service practice collects \$1.1 million and nets \$450,000. Refers all endo, all perio, all surgery and all ortho. Asking \$850,000. Kurt Skarin 805-777-7707.

Thank you for helping me with all my insurance needs. I appreciate your time and professionalism in getting this done quickly! - Yaron Miller DDS, San Diego. www.TheDoctorsInsuranceBroker.com, jonathan@tdibroker.com or call 800-767-0864.

Endodontists available at your office. We will bring our equipment, supplies, microscope, assistant. NO INVESTMENT needed on your part. smartendo1@gmail.com.

They made the process of building my office much easier. Made the stress of opening a new office much easier. Dr. R. Pullen. 714-240-7179 (All County).

Well slap my butt and call me Spanky...I can subscribe, change my address or cancel my free Dental Trader subscription anytime at <http://www.thedentaltrader.com>.

SAN JOSE Great location. Busy 6 op practice with room for growth. Call today! IntegrityPracticeSales.com, Broker Bill Kimball, DDS, BRE #01911548. (855) 337-4337.

Free Retirement Plan Feasibility Study with every incorporation. Attorney Robert W. Olson, Jr., 805.963.1120, www.transdental.com.

RDA and front office positions available. Must be bilingual (Eng/Sp) and have 1-2 years experience. Email resume to dentalcareers@shareourselves.org.

DENTAL HANDPIECE REPAIR 50% OFF New Customers Only. Premium Parts Standard. Contact Us Today! 877-535-1733 / www.repairmakers.com.

Perfect Apical Seal With Life Time Warranty For ALL Inoperable Endo. I Provide Everything. visit: www.socalrootcanal.com.

Rebella Accountancy has helped me in the purchase of two dental practices, the formation of my corporation, and has assisted in soundly guiding me in establishing my financial portfolio. Mark B. Jamison, D.D.S (714) 619-0667 www.rebellacpa.com.

Attend 2 Lectures + a Hands-on Direct Composite Veneers Course (21 CA & AGD CEs) for only \$449, all on Sundays, in a convenient OC location! Visit www.xcelseminars.com for info.

If delivering a better dental experience for your patients is your goal, upgrading or expanding your practice is one of the best investments you can make. Call Wells Fargo Practice Finance at 1-888-937-2321.

Don't let worn upholstery be your patient's first impression! Superior Upholstery Company 888-548-7282 superiorupholstery.com.



Greg Beamer, Dental Broker
Experience in Finance and Brokerage since 1976

GB **GREG BEAMER**
DENTAL BROKER

The Name You Know
The Reputation You Trust

- 22 + YEARS EXPERIENCE
- FULL-SERVICE BROKERAGE
- PROVIDES BUYER OR SELLER REPRESENTATION
- APPRAISALS AND EVALUATIONS
- PRACTICE TRANSITIONS
- FINANCIAL ASSISTANCE

Selling Your Practice Requires Experience, Guidance and Support

Whether you are moving, expanding or retiring, it helps to have someone to assist you along the way. Many have tried to do it on their own – it can be frustrating, time-consuming and costly as it takes time away from you doing what you do best - dentistry. I have 22 years of experience helping clients through the transition process and each situation is different. Anyone can put buyers in your hands, but you need someone to help you through the entire process. I have the tools to help you get where you want to go, and the knowledge to finish the task.

Give me a call – let's chat.

"Very recently I sold my dental practice and the building I inherited from my father. I was completely ignorant as to how to do any of this. Greg helped me through this very difficult and emotional process, literally holding my hand. He explained things and was always available with assistance, sound advice, and a solution. His years of experience in the selling of dental practices in addition to his inside knowledge of banking institutions and escrow people was invaluable. He made a difficult and technical process a much safer and understandable experience for me. With every bump in the road, no matter how big or small, Greg was there to help me navigate it. He had my back 100% of the time. I got the best outcome possible – he knows what he is doing. You are not just another client with Greg. He is your partner and will be there for you."

Mike Hanrahan DDS

(909) 542-4891 phone
(866) 890-1033 fax

info@gregbeamer.com • www.gregbeamer.com

PRACTICE FOR SALE TORRANCE GP in shopping center w/ 3 eq ops; \$28K/mo California Practice Sales, Inc. Phone: 714-639-2775.

Custom built stools Big seat, little seat, tall or short. We can fit any human...Superior Upholstery Company 888-548-7282 superiorupholstery.com.

PRACTICE FOR SALE TORRANCE/LAWNDALE AREA 1,000 sq.ft. in a busy/high traffic plaza, asking \$120k Starter Practice 13 yrs. of goodwill. call 310-365-3583.

"When I called Jason for professional help on an estate issue I was having, he promptly met with me in his office to help resolve the matter. He was very friendly and extremely helpful. He was able to resolve my issue with an email and his opinion letter that I left his office with. I would highly recommend Jason Wood and his office to my family and friends". "Thank you again. You guys are the best!" CAROLN COLLINS (On behalf of THOMAS BOONE, DDS) Sunset Beach, California. WOOD & DELGADO www.dentalattorneys.com.

Attend 5 top-notch lectures (35 CA & AGD CEs) for only \$475, all on Sundays, in a convenient OC location! Visit www.xcelseminars.com for info.

Speak with an experienced dental attorney today about practice transition legal pitfalls. Levi Barlavi. (888) 776-5384 www.dental-attorney.com.

Lowest prices on Regenerative Products- Buy 3 get 1 on all Miltex Collagen Products! 15 x 20mm Helimends @66.00 www.dentalprodx.com.

Looking for Dentists for PEDO - Need experienced associates for BUSY beautiful Pedo offices thru out Los Angeles w excellent staff support. Dr Bae 310- 738-8020 (willing to train new grads).

Whether you need help funding a ground up construction project, purchasing commercial property, refinancing or consolidating existing loans or acquiring a practice, Live Oak Bank can help. 877.890.5867 www.liveoakbank.com/healthcare.

Is now the right time to list your practice? Find out from Mario Molina, Henry Schein PPT 323-974-4592.

"Last minute review of Buy-Sell Agreement. Call today for fixed pricing!" Law Offices of Amy L. Borden, Esq. (888)416-1321. www.californiadentalattorney.com.

Close office end Sept, everything must go 2 full op, office supply etc must see. Contact email or 5623283626.

NO MORE GRAFTS! Learn to treat gum recession in one appointment with no grafts, incisions or sutures and overnight recovery period! Visit pinholesurgicaltechnique.com.

PRACTICE FOR SALE ANAHEIM GP w/ 24 yrd gdwill; Proj \$497K for 2015 California Practice Sales, Inc. Phone: 714-639-2775.

ASEPTICO AIRPAC Air Compressor AA-74SA-110, Like New, Cost \$900, Make Offer. 855-772-7645 or janetm@hygiacare.com.

Professional Services Need a local bank that can meet your closing date and **FUND YOUR LOAN FAST?** Call Sunwest Bank 714-730-4412.

Clean out that junk drawer and sell the stuff you don't need.

Place a **FREE AD** and turn your unwanted items into cash! Ads placed online post instantly to our website.

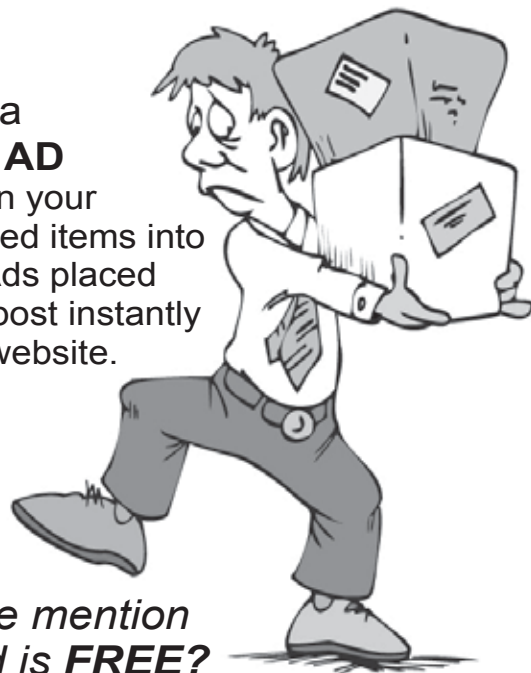

Did we mention the ad is FREE?

Visit our FAQs page at **dentaltrader.com** for details

FAST, PERSONAL LOCAL, COMPETITIVE FINANCING... At Orange County Business Bank you aren't just a loan. You'll get your financing done fast, without the red tape of bigger banks! Contact Howard Boles 949-379-5704 Equal Housing Lender-The bank makes such loans without regard to race, color, religion, national origin, sex, marital status, age, handicap, familial status, applicant's receipt of income from any public assistance and applicant's exercise, in good faith, or any right under the Consumer Credit Protection Act. Member FDIC.

General Dentist Needed!! for a Growing multi Practice company. Valid California License & 3 yrs+ Experience required. TOP PAY! please email your resume at rocio@assuredentalcare.com.

Brand new Hereaus Dynamix 6650124 (henry schein price 2423.79 before tax) asking 1900.00 call Dr. Tim 5623353665.

EpiPen Epinephrine Auto-Injector Adult 0.3mg. Expiration: July, 2016. MSRP \$550 for 2 pack. FOR SALE \$175 FOR ONE. gaw1177@gmail.com.

Luis Kong, DDS (San Francisco, CA)- Thank you Dr. Chester Jeng of Law Offices of Jeng and Associates. Your prompt attention to my concerns is something I am so thankful for. Definitely, you are the "go to" attorney for me. Call Jeng & Associates 714-858-0536.

All County Construction High Quality and Great Service within YOUR Budget! Specializing in Dental / Medical Construction since 1991. (714) 240-7179.

"Greg is great at finding the best buyers, extremely attentive, professional and competent. Nice guy too!" Mark Helm, DDS. Greg Beamer, Dental Broker 909-542-4891.

DENTAL DIRECTORY



PRACTICE SALES & APPRAISALS

*Reliability & High Ethical Standards
You Can Trust - Proven Results
You Can Count On*

Lou Bermudez, Broker or
Frederic Sherman, DDS, Broker
(714) 999-9595 • (818) 999-9595 (main office) • Fax: (818) 999-9615

**Over 200+ Dentists Choose Monica Rebella as
their SoCal CPA & Accountant, listen why at:
MyDentalCPA.com or call 714-619-0667**



I've had Monica as my accountant for over 15 years. I really like her. I actively refer to her and the reasons are she's a strategic accountant.
James E. Bollinger, D.D.S.

Monica is a very able accountant & has done a fine job for both my orthonic practice as well as my wife's care giving business for the last 5 years.
William Brady DDS Ms Orthodontics



Go for the best - Get the *Highest Rated Software* by the ADA*

800-273-5033

Online demo - www.ez2000software.com

GB GREG BEAMER DENTAL BROKER



The Name You Know
The Reputation You Trust

(909) 542-4891 phone
(866) 890-1033 fax
DRE License # 01149524
info@gregbeamer.com
www.gregbeamer.com

HENRY SCHEIN® PROFESSIONAL PRACTICE TRANSITIONS

No. CA: 1.800.519.3458 • So. CA: 1.888.685.8100

ppt@henryschein.com
www.henryscheinppt.com



LCF FINANCIAL SERVICES

Healthcare Financing & Consulting

***Low rates
for qualified borrowers**

(714) 550-7494 • www.lcffin.com

A Division of LCF Financial, Inc. *OAC

KINGS TWO DENTAL SUPPLY

Your One Stop Dental Shop

- Large Equipment
- Small Equipment
- Service Department
- Dental Supplies
- Ortho Products
- Digital Imaging
- Implantology
- Handpiece Repair
- Full Service Dental Lab

Tel: 800.715.5464

Fax: 626.581.8137

Full Service Collections

We feature:

- Commission Fee Only
- Free Credit Bureau Reporting
- Spanish Speaking Collectors
- Full skip tracing & legal department
- Comprehensive month end and on demand reports
- Friendly experienced staff

DCC, Inc.

269 S. Beverly Dr., Suite 439
Beverly Hills, CA 90212



Dental Collection Specialists

888-860-2950

www.DirectCreditControl.com

LEE SKARIN AND ASSOCIATES, INC.

KURT SKARIN

DENTAL PRACTICE SALES & APPRAISALS

530 W. Stafford Road, Westlake Village, CA 91361
805.777.7707 • 800.752.7461 • Fax: 805.777.0051

Email: lsainc@aol.com

www.leeskarinandassociates.com



CA DRE: 00863149

ALL COUNTY CONSTRUCTION Dental Office Design

DESIGN/BUILD

T.I.'s • Remodels • Expansions • Free Standing Buildings
Turn-Key Packages • Consultation

Free Estimates

562-989-3350

Lic. #669244

888-302-6111

DENTAL DIRECTORY



CALIFORNIA PRACTICE SALES INC.



John W. Knipf
President

Robert A. Palumbo
Executive Vice President

326 W. Katella Ave. #4-G, Orange, Ca 92867
(714) 639-2775 • www.calpracticesales.com

CA DRE #00491323

Rope in Profits!



www.DentalTrader.com

THE #1 DENTAL LAW FIRM IN THE NATION



WOODANDELGADO

- Legal Advisors to over 15 Dental Societies
- The Chosen experts on Business Transactions for Dentaltown
- 180+ Dental Practice Transitions in 2014
- Providing service to clients NATIONWIDE



Patrick J. Wood,
Jason P. Wood
& Marc Ettinger
Attorneys at Law

800-499-1474
www.DentalAttorneys.com



PRACTICE SALES AND LEASING
"THE PERSONALIZED SERVICE DENTAL BROKER"®



Paul Maimone
Broker/Owner

P.O. Box #6681, Woodland Hills, CA 91365
Phone: 818.591.1401 • 866.425.1877 Outside So. CA
www.dmpractice.com

CA Broker Lic. #01172430



Thomas & Fees

Practice Sales
"A better kind of practice sales company"

Philip L. Kempler, DMD, Broker

Days: 714-544-4341 • Eve: 949-362-4749 • Fax: 714-731-7296

E-mail: Phldr@cox.net

TAX • FINANCIAL ADVISORY • VALUATION

CUONG LE, CPA



2020 Pico Blvd., Suite C
Santa Monica, CA 90405

(310) 450-5708
info@lecpa1.com

Success Through Diligence

Commercial Bank



Citi Healthcare Practice Finance

- Practice Acquisitions
- Partnership Buy-ins/Buy-outs
- Practice Loan/Debt Consolidation
- Expansion/Remodel/Relocation



Call Bob Affleck | 949-939-4550 | bob.affleck@citi.com
Checkout our ad/read what your colleagues say about us



Ken Rubin & Company, Dental CPA's
Ken Rubin Practice Sales
619.299.6161

www.kenrubincpa.com
www.krpracticesales.com



San Diego Practice Sales

- represents Sellers and Buyers
- exclusively in San Diego County
- more than 28 years of experience with the San Diego Dental Community

For More Information Call:

(760) 599-7828

WWW.SDPRACTICESALES.COM

CPR CLASS IN YOUR OFFICE

- LOW MINIMUM STAFFING NUMBERS AND LOW RATES
- BOARD APPROVED 2 YEAR CERTIFICATION
- LENGTH OF COURSE 1 1/2 - 2 HOURS MAX
- EARN 4 HOURS OF BOARD APPROVED C.E. UNITS

Heartstart CPR
(626)797-6179

WWW.CPR4DENTISTS.COM



DENTAL DIRECTORY

REPAIRMAKERS

DENTAL EQUIPMENT REPAIR PROS

Schedule Service 877.535.1733
www.repairmakers.com



RECEIVE A \$75* CREDIT W/ 1ST ORDER.

PROFESSIONAL PRACTICE LENDING PROGRAM

- Practice Acquisitions
- Partnership Buy-ins and Buy-outs
- Refinance and Debt Consolidation
- Expansion and Relocation
- Equipment Purchases



Call Howard Boles
(949) 379-5704



hboles@ocbusinessbank.com



Orange County
BUSINESS BANK

GET ON BOARD!!

Make an easy ride for yourself!
Let your ads do the work!



www.dentaltrader.com



Your voice for excellence
through education and advocacy

The only organization dedicated to the needs of the general dentist.
Learn more about everything that AGD has to offer by visiting

www.agd.org and

Join Today!

Call toll-free at 888.AGD.DENT (888.243.3368)

ROBERT W. OLSON, JR.

a Professional Corporation
Business, Corporate & Real Estate Law

- USC Law 1984, Dartmouth 1981
- All Inclusive Packages
- Free Website Services

888.963.1120

www.transdental.com

RWO@transdental.com



Alex Hornaman General Flooring

- All types of Unique Wood Flooring
- Installation with designs, patterns, inlays
- Base/Case/Crown Molding Installation. Since 1996

Alex Hornaman
Call 714.390.3250
Fax: 714.841.0496

Licensed & bonded #801982



Practice Financing

WELLS
FARGO

Call us for a complimentary consultation today.

Sina Mansouri
1-855-544-0245

Jason Schneller
1-888-220-7321

Kris Nishihira
1-855-405-2107

Or visit us at wellsfargo.com/dentaltrader.



Tired of Paying Your Silent Partner 50%?

Keep more \$\$\$ by lowering your tax bite

Can your tax preparer answer these questions:

- How can I deduct \$734 per day for business travel?
- How can I write-off 25% of my home expenses as business-related expenses?
- How do I deduct 100% of the cost of a home repair?
- How do I deduct \$50,000 for the cost of my vehicle?
- What items in my building can be expensed over 5 years?



Raymond Furness, CPA, M.S. Tax

Tel: 818.990.0686 | www.FurnessCPA.com | Raymond@FurnessCPA.com



wlads@pacbell.net • westernlads.org
14722 Hawthorne Blvd. Ste B
Lawndale, CA 90260-1505
310-349-2199

Don't sign that lease! The new trend in commercial property lease agreements is to include terms that are so one-sided, you lean when you read em! Get an expert review BEFORE SIGNING. Call Kerendian & Associates 888-299-7848.

WANTED Current address of Kurt Conrad dba: Conrad Capital Kurt Conrad-Director of Professional Lending aka: Rep OZARKS CAPITAL FUNDING Last known address: 45751 Rancho Palmaras, Indian Wells, CA 92210 www.ocfl ink.com email: kurt.conrad@ocfl ink.com Ph: 949-300-2433 Fax: 949-759-0746. Please contact Bruce at The Dental Trader if you know the current whereabouts of this former advertiser. Thank you. 877 888 4237.

DENTAL HANDPIECE REPAIR 50% OFF New Customers Only. Premium Parts Standard. Contact Us Today! 877-535-1733 / www.repairmakers.com.

Periodontist in your San Diego/Orange County office: immediate implants, IV sedation, perio surgery, bone grafts, third molars, crown lengthening, root coverage, All-on-4/6, full mouth rehabilitation, etc. Will bring all supplies and instruments. Very personable, great with patients. 619-804-8339 or socialperiodontist@gmail.com.

ASSOC DDS WANTED ANAHEIM/LA office. (Min 3 years experience required) Great pay/bonus. Please Email resume socialteeth@gmail.com.

implantasmile.com is looking for an associate dentist with over 3 years' experience with the desire to join our start of the art organization in either Glendora, CA or Huntington Beach, CA. implantasmile.com focuses on all aspects of general, cosmetic, restorative, prosthetics, and reconstructive & surgical dentistry. E-mail your CV to dr@implantasmile.com.

Approximately 1000 Sq. Ft. space by Subway, Starbucks & CVS in Paramount at Lakewood & Alondra intersection for private dental office. 323-653-8563.

Spanish speaking dentist wanted part time. With possible interest in buying practice in the future. Please email me at ktisbs@yahoo.com.

DDS/DMD NEEDED FOR WEDNESDAYS IN HUNTINGTON PARK. GREAT FAMILY OFFICE. SECURE ENCLOSED PARKING. PLEASE CALL (323)585-1000.

Orthodontist looking to partner with a Pediatric office or partner with Pedodontist to start one. Contact: ortho_wiz@yahoo.com.

AirTechniques AT 2000 XR. \$1000 OBO. Last used 10/14. Manual/cleaning films incl. Year Unknown. Will Email Pix. 661-823-7644.

COLLECTIBLE 1950s Ritter dental unit and chair for display or collector. Very good condition. Asking \$500. Any offer considered. cdentaljohn@aol.com.

LA office for sale Approx 2k sqft, 3 operatories, fully digital. Gross prod 400k, low overhead. Asking \$350k. joyeuna72@hotmail.com.

Specialist needed for new office in Irvine spectrum. Please, fax 949-552-7900.

NEED PEDIATRIC DENTIST BAKERSFIELD P/T, SEND CV AT luismiguelcollazos@yahoo.com, 6613272155 6613274122, fax 6613272528.

CHANGE OF ADDRESS FORM

THE Dental Trader
Buy, Sell or Trade all things Dental

OLD ADDRESS

Dentist's Name _____

Address _____

City/State/Zip _____

NEW ADDRESS

Dentist's Name _____

Calif. Dental License # _____

Address _____

City/State/Zip _____

Phone _____ Fax _____

E-mail _____

Authorizing signature _____

PLEASE MAIL TO:
PO Box 2631, Capistrano Beach, CA 92624
or Fax this form to 949.498.1198
on or before the 1st of the month.
For faster filing, submit this form online at:
www.dentaltrader.com

Multi-specialty dental office in Orange County available to share space with other dental specialists. Call (949)363-3914 or email: lesasaunders@gmail.com.

Endodontist needed twice a month in Rancho Cucamonga / Ontario area. Please send resume or CV to shashimi100@hotmail.com.

Looking for a part-time dentist in West Covina. Please email resume to: RubinNicholsDDS@gmail.com or fax to (626) 333-4666.

NEW Aseptic portable dental unit Self contained Irrigation and Evacuation System ADU-17X & Portable asepticlight 110V ALU-29 Call (909)217-0814.

Chemiclave 5000 AT 2000 film processor, safe light, Foster model trimmer, workstation carts, all in good working condition. (909)910-1688.

Selling I-CAT FLX. Purchased new May, 2014 list price \$154,999 remaining warranty transferable. \$100,000 OBO Call (707)4670875.

Need an RDA for upbeat orthodontic office. Hard working, team player, willingness to learn. Orthodontic experience ideal. Competitive pay. Call Judy at 310-785-0770.

Copyright 2015 THE DENTAL TRADER. All rights reserved. No part of this publication may be reproduced or transmitted in any form or by any means, electronic or mechanical, including photocopy, recording, or any storage of information and retrieval system.

PLACE YOUR ADS WITH US ONLINE www.dentaltrader.com

Review FAQs page for instructions on reader ad submission **BEFORE** using form.

**IT'S
EASY!!**



THE Dental Trader™

Buy, Sell or Trade all things Dental

Our Advertisers

All County Construction

Alliance Consulting Group

Allied Health Products

American Dental Specialists

Appliance Therapy Group - Space
Maintainers Lab

Ararat Pharmacy

Mailing Address: The Dental Trader PO Box 2631 Capistrano Beach, CA 92624

PH: (877) 888 4237 or (949) 429 6836 - FAX: (949) 498 1198 - E-Mail: tradestaff@cox.net

| [Home](#) | [Place a Free Reader Ad](#) | [Reader Ads for Businesses](#) | [Online Ad Board](#) | [Dental Links](#) | [Proof of Circulation](#) |
| [FAQs](#) | [Testimonials](#) | [Latest Edition](#) | [Archived Copies](#) | [Place a Display Ad](#) | [Submit a Change of Address](#) | [Contact](#) |

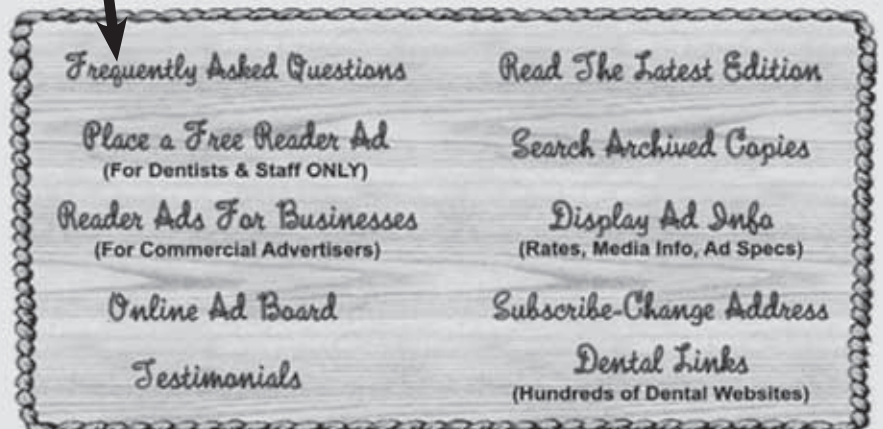

The FAQs link shown above will bring up step by step instructions on how to place your ad. Once you have typed in your ad, selected your options (bold text, black border or black box w/ white lettering), please double check your spelling and make sure your contact information is correct. Your ad will appear both in the printed publication and on the Ad Board exactly as you entered it. We do not accept ads submitted anonymously.

The deadline for submitting ads online is always the 7th of the month.

“SANTA BARBARA COUNTY WINE COUNTRY” G.P. PRACTICE AND 1,900 SQ FT BUILDING FOR SALE



- (3) OP COMPUTERIZED G.P. IN A FREE STANDING BUILDING
- SALE INCLUDES A 1,900 SQ FT BLDG WHICH HOUSES THE PRACTICE & A RESIDENTIAL UNIT. LIVE IN UNIT OR RENT IT
- “FEE FOR SERVICE” PRACTICE. NO HMO, PPO OR DENTI-CAL
- 2015 PROJECTED GROSS COLLECTIONS \$280K PART TIME WITH GROWTH POTENTIAL
- SELLER REFERS ALL O.S., ENDO, IMPLANT PLACEMENT, ORTHO, AND PERIO, AND DOES LITTLE ADVERTISING
- SELLER RETIRING BUT WILL ASSIST WITH AN ORDERLY TRANSITION



CA Representative for The National Association
of Practice Brokers (NAPB)

Call Today



For all your Practice Transition Needs!

*Trust your Practice Purchase or Sale to
The Personalized Service Dental Broker®*

818.591.1401 or
866.425.1877
(Outside So. CA)

www.dmpractice.com

P.O. Box 6681, Woodland Hills, CA 91365

CA Broker License #01172430

REPLACEMENT UPHOLSTERY FOR CHAIRS AND STOOLS

*Reduce the down time and costs of
traditional reupholstery with
Superior's custom made to order,
precision cut reupholstery kit!
Easily installs in minutes!!*

From \$595

OPTIONS AVAILABLE:

Memory Foam
Ultraleather
Relaxor Massage Systems

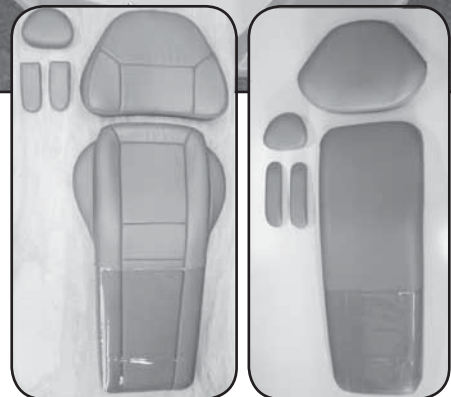

Superior
UPHOLSTERY COMPANY

www.superiorupholstery.com

888-548-7282

For Refurbished Equipment, visit www.superiordds.com